

REGO

HF Inverter Charger

12V | 3000W

RIV1230RCH-SPS

 **RENOGY**[®]

Find Your Energy Freedom[™]

VERSION A0

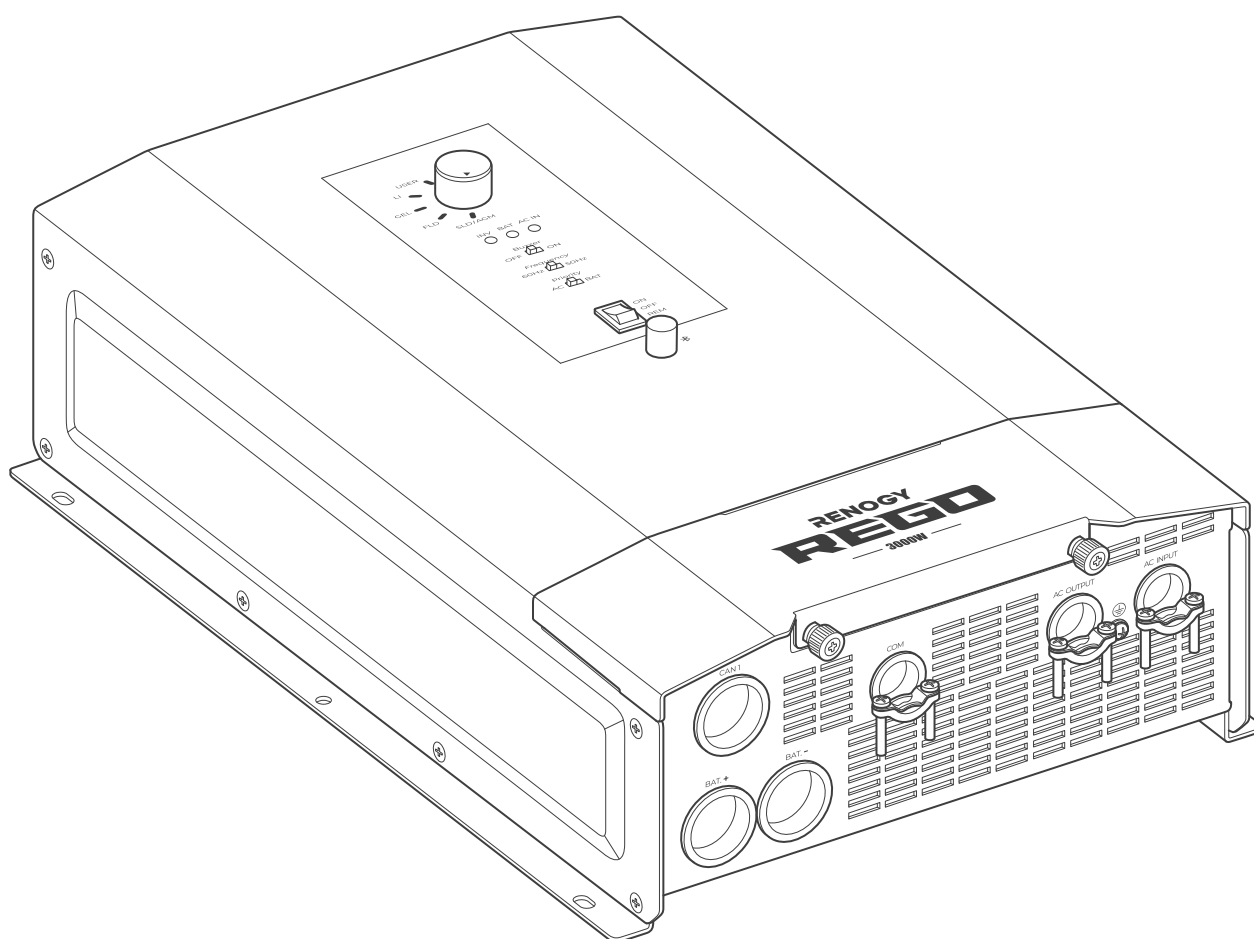

USER MANUAL

Before Getting Started

The user manual provides important operation and maintenance instructions for REGO 12V 3000W HF Inverter Charger (hereinafter referred to as inverter charger).

Read the user manual carefully before operation and save it for future reference. Failure to observe the instructions or precautions in the user manual can result in electrical shock, serious injury, or death, or can damage the inverter charger, potentially rendering it inoperable.

- Renogy ensures the accuracy, sufficiency, and the applicability of information in the user manual at the time of printing due to continual product improvements that may occur.
- Renogy assumes no responsibility or liability for personal and property losses, whether directly and indirectly, caused by the user's failure to install and use the product in compliance with the user manual.
- Renogy is not responsible or liable for failures, damages, or injuries resulting from repair attempted by unqualified personnel, improper installation, and unsuitable operation.
- The illustrations in the user manual are for demonstration purposes only. Details may appear slightly different depending on product revision and market region.
- Renogy reserves the right to change the information in the user manual without notice. For the latest user manual, visit [renogy.com](https://www.renogy.com).

Disclaimer

REGO 12V 3000W HF Inverter Charger User Manual © 2023 Renogy. All rights reserved.

RENOGY and **RENOGY** are registered trademarks of Renogy.

- All information in the user manual is subject to copyright and other intellectual property rights of Renogy and its licensors. The user manual may not be modified, reproduced, or copied, in whole or in part, without the prior written permissions of Renogy and its licensors.
- The registered trademarks in the user manual are the property of Renogy. The unauthorized use of the trademarks is strictly prohibited.

Online Manual

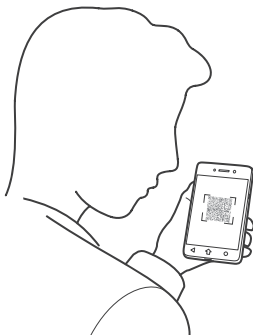

Quick Guide



User Manual



DC Home App

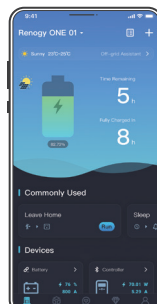

DC Home App

GTE IT ON
Google Play

Download on the
App Store

Table of Contents

1. General Information	1
1.1. Symbols Used	1
1.2. Qualified Personnel	1
1.3. Introduction	1
1.4. Key Features	1
1.5. SKU	2
2. Get to Know REGO 12V 3000W HF Inverter Charger	3
2.1. What's In the Box?	3
2.2. Recommended Tools	3
2.3. Product Overview	4
2.4. System Setup	5
3. Preparation	6
3.1. Plan a Mounting Site	6
3.2. Check the Inverter Charger	7
3.3. Check the Battery	8
3.4. Check the AC Loads (Appliances)	10
3.5. Check the AC Generator or the Grid (Optional)	11
3.6. How to Properly Install Cable Clamps?	12
4. Installation	13
4.1. Wear Insulating Gloves	13
4.2. Mount the Inverter Charger	13
4.3. Remove the Cover	13
4.4. Ground the Inverter Charger	14
4.5. Install a Wired Remote Control	15
4.6. Install a Battery Voltage Sensor	16
4.7. Install a Battery Temperature Sensor	18
4.8. Connect the Inverter Charger to a Battery	19
4.9. Connect the Inverter Charger to AC Loads (Appliances)	21
4.10. Connect the Inverter Charger to the Grid	24
4.11. CAN Communication Wiring (Optional)	29
4.12. Inspection	32
4.13. Install the Cover	32
5. Configuration	33
5.1. N-G Bonding Relay	33
5.2. Configuration Panel	34
5.3. Set a Battery Type	34
5.4. USER Mode	35
5.5. Enable/Disable the Buzzer	37
5.6. Set an AC Output Frequency	37
5.7. Set an AC Output Priority	37

6. Power On/Off and LED Indicators	38
6.1. Power On/Off	38
6.2. LED Indicators	39
7. Monitor the Inverter Charger	40
7.1. Short-Range Monitoring via DC Home App	40
7.2. Wireless Long-Range Monitoring	41
7.3. Wired Long-Range Monitoring (Backbone Network)	42
7.4. Wired Long-Range Monitoring (Daisy Chain Network)	43
8. Working Logic	44
8.1. Power Supply Logic	44
8.2. Charging Logic	45
8.3. Battery Charging Stages	46
8.4. Heat Dissipation Logic	47
8.5. Activation Logic for Lithium Battery	47
8.6. Heating Module Activation Logic for Lithium Battery	47
9. Troubleshooting	48
10. Dimensions & Specifications	49
10.1. Dimensions	49
10.2. Technical Specifications	49
11. Maintenance	51
11.1. Inspection	51
11.2. Cleaning	51
11.3. Storage	51
12. Emergency Responses	52
12.1. Fire	52
12.2. Flooding	52
12.3. Smell	52
12.4. Noise	52
Renogy Support	53

1. General Information

1.1. Symbols Used

The following symbols are used throughout the user manual to highlight important information.



WARNING: Indicates a potentially hazardous condition that could result in personal injury or death.



CAUTION: Indicates a critical procedure for safe and proper installation and operation.



NOTE: Indicates an important step or tip for optimal performance.

1.2. Qualified Personnel

The installation and service of the inverter charger must be carried out by qualified personnel. Qualified personnel refer to trained and licensed electricians or installers with all the following skills and expertise:

- Knowledge of the functional principles and operation of on-grid and off-grid energy storage system.
- Knowledge of the risks and dangers associated with the installation and service of electrical devices and acceptable mitigation methods.
- Knowledge of the installation and service of electrical devices.
- Knowledge of and adherence to the user manual and all safety precautions and best practices.
- Knowledge of local installation regulations.
- Electrical license for the installation and service of energy storage system required by the county or state.

1.3. Introduction

REGO 12V 3000W HF Inverter Charger is your off-grid smart living center that revolutionizes comfort when you live in your off-grid home or RV. The inverter charger can invert DC to AC and directly supply power to the load, and charge the battery when it is connected to the utility power.

In addition, it supports different types of batteries such as lithium, GEL, flooded, SLD, and AGM batteries. The inverter charger can switch power supply from the grid power to batteries within 10 milliseconds, ensuring a smooth mode switch without powering off the load. The lever style connectors make AC IN/OUT connections simply and easy. They simplify installation and shorten the installation time.

The inverter charger can be connected to Renogy devices and smart accessories via Bluetooth or RV-C. When the inverter charger works in association with the DC Home app or Renogy ONE, you will have the same system monitoring wherever you go on your smartphone. With advanced pure sine wave technology, the inverter charger can protect and extend the life of your electronic equipment and loads.

1.4. Key Features

- **Battery versatility and easy-to-configure settings**
Compatible with four preset battery types and allows custom parameter settings. Provides simple switch setup for battery type, output frequency, and input priority setting.
- **Multi-stage battery charging and customizable charging**
Offers up to three-stage charging for various battery types and supports adjustable charging current (up to 150A) to suit your daily power needs.
- **Dual voltage support and high-current output**
Compatible with single-phase 120V and split-phase 120V/240V.
Integrates a 50A AC Transfer Relay for continuous 50A current to AC output when connected to both the grid and battery.
- **Built-in Bluetooth**
Connects to DC Home app for energy data monitoring, control, and configuration and supports OTA firmware upgrades.

- **High conversion efficiency thanks to quality pure sine wave**
Achieves peak conversion efficiency of over 90%, reducing energy loss thanks to the smooth AC power with minimal harmonic distortion, equivalent to grid power quality.
- **Automatic generator start**
Equipped with dry contacts for automatic generator start and stop function, facilitating battery charging.
- **Multiple protections**
Provides undervoltage, overvoltage, overcurrent, overload, overtemperature, and short circuit protections for enhanced safety.

1.5. SKU

REGO 12V 3000W HF Inverter Charger	RIV1230RCH-SPS
------------------------------------	----------------

2. Get to Know REGO 12V 3000W HF Inverter Charger

2.1. What's In the Box?

REGO 12V 3000W HF Inverter Charger x 1

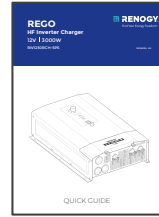
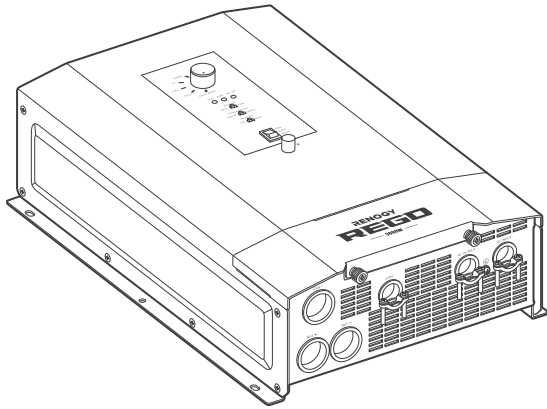

Quick Guide x 1



Wired Remote Control x 1

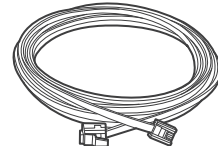

RJ12 Cable (5m) x 1

ST6.3 x 1.8 x 13 mm

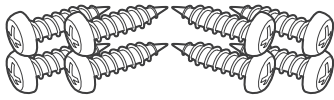

Self-tapping Screws x 8
(2 extra)

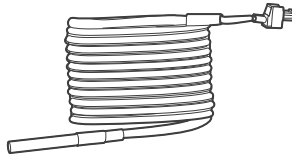

Battery Temperature
Sensor x 1

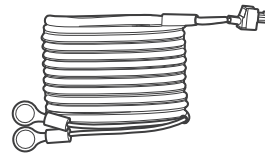

Battery Voltage
Sensor x 1

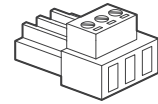

Dry Contact Relay
Connector x 1



Make sure that all accessories are complete and free of any signs of damage.

2.2. Recommended Tools



Phillips Screwdriver (#2)



Slotted Screwdriver (1 mm)

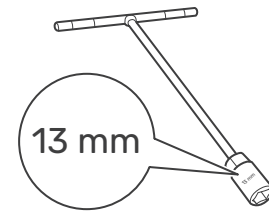

Socket Wrench (17/32 in)

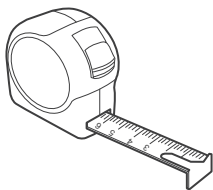

Measuring Tape



Wire stripper

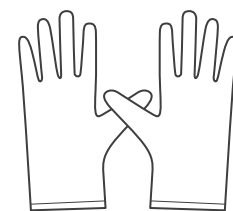

Insulating Gloves



Prior to installing and configuring the inverter charger, prepare the recommended tools, components, and accessories.

2.3. Product Overview

Exterior

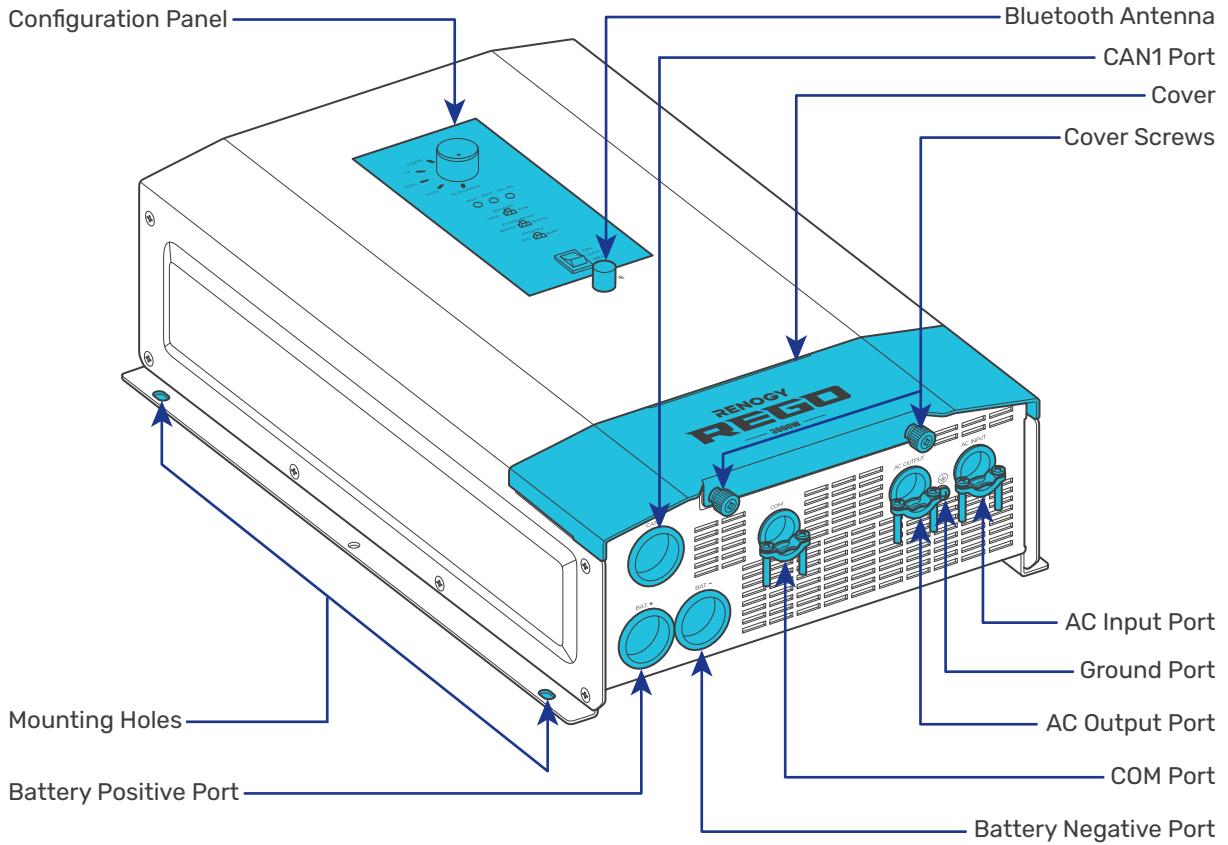

Interior (with the cover removed)

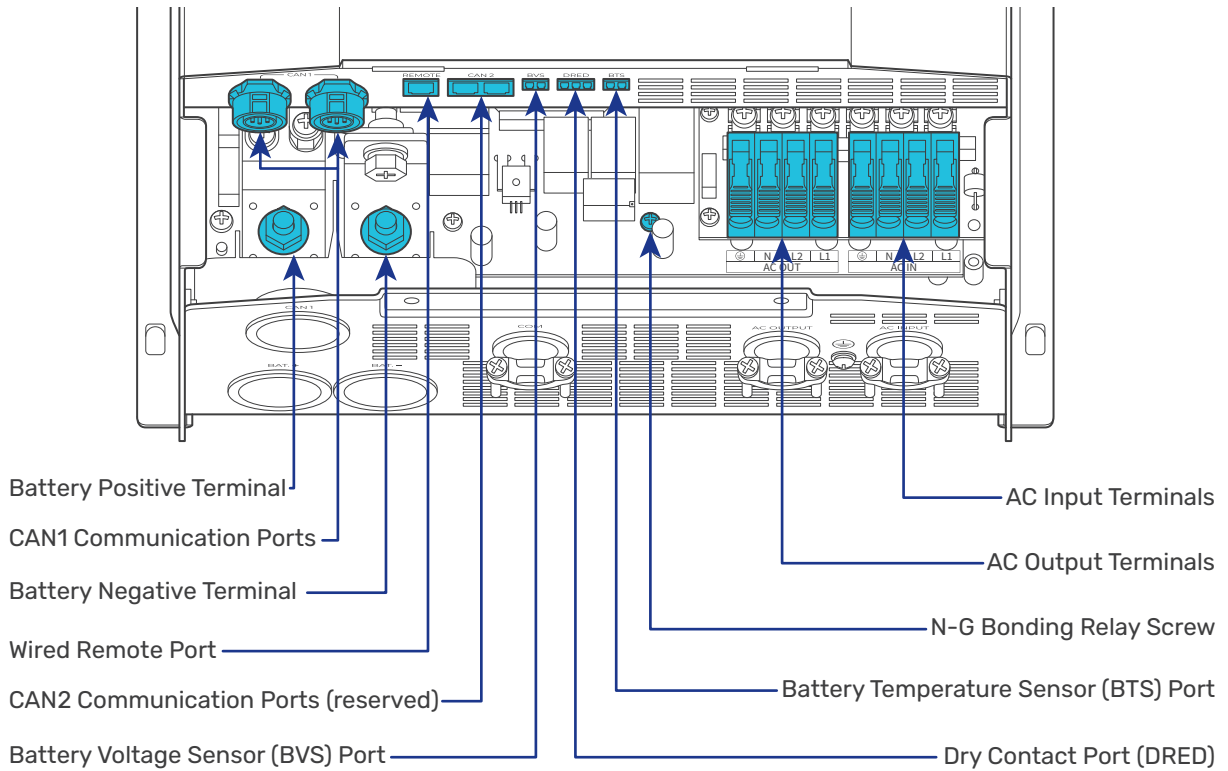

The BTS port can only be used with lead-acid batteries.

2.4. System Setup

- Live wire (AC) — Positive (DC) — Ground — BTS — Remote control
- Neutral wire (AC) — Negative (DC) — Communication — BVS

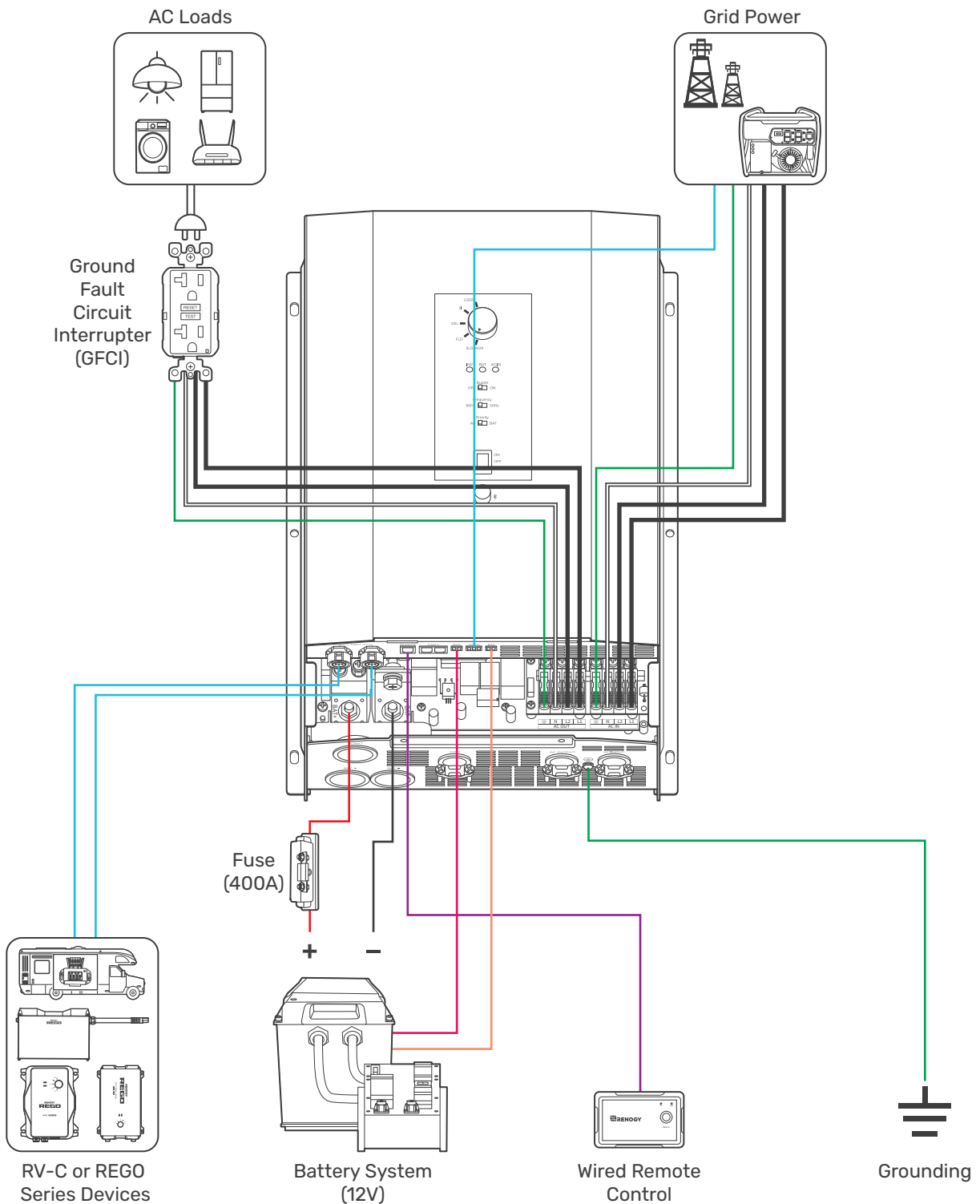









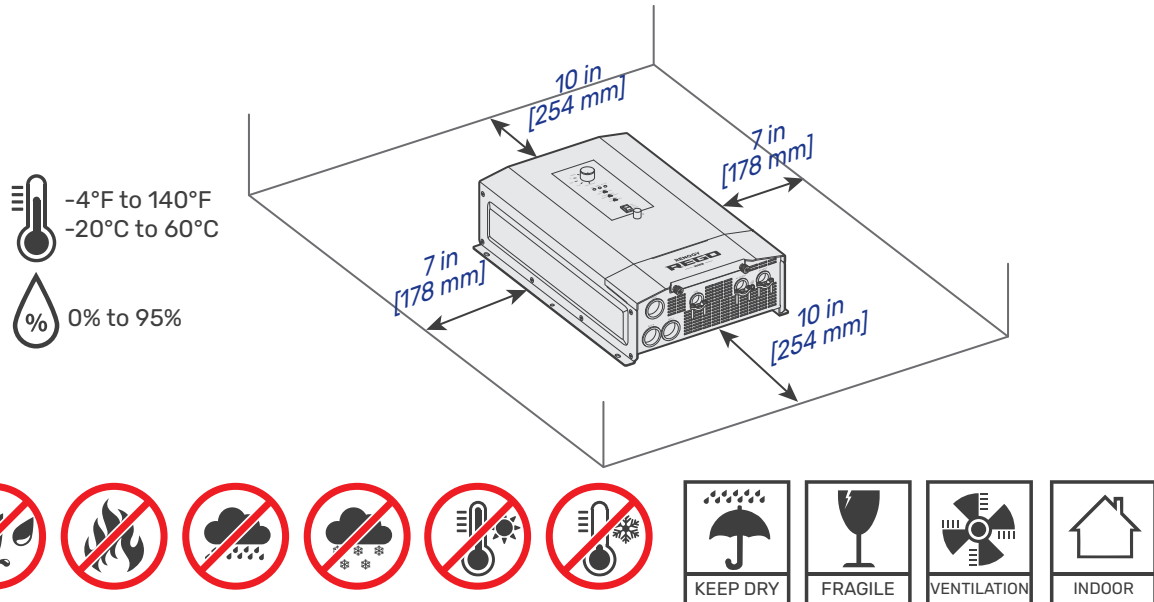



- i** The wiring diagram only shows the key components in a typical DC-coupled off-grid energy storage system for the illustrative purpose. The wiring might be different depending on the system configuration. Additional safety devices, including disconnect switches, emergency stops, and rapid shutdown devices, might be required. Wire the system in accordance with the regulations at the installation site.
- i** The connection of AC IN ports vary depending on the connected grid systems. For single-phase 120V grid systems, only AC IN L1 and AC IN N ports are used for the input. For split-phase 120V/240V grid systems, AC IN L1, AC IN L2, and AC IN N ports are used for the input.

3. Preparation

3.1. Plan a Mounting Site

The inverter charger requires adequate clearance for installation, wiring and ventilation. The minimum clearance is provided below. Ventilation is highly recommended if it is mounted in an enclosure. Select a proper mounting site to ensure the inverter charger can be safely connected to the battery and grid/AC generator with the relevant cables.



-  Risk of explosion! Never install the inverter charger in a sealed enclosure with flooded batteries! Do not install the inverter charger in a confined area where battery gases can accumulate.
-  The inverter charger should be installed on a vertical surface protected from direct sunlight.
-  Keep the inverter charger out of the reach of children and animals.
-  Do not expose the inverter charger to flammable or harsh chemicals or vapors.
-  Make sure that the inverter charger is installed in a place at ambient temperature from -4°F to 140°F (-20°C to 60°C).
-  Make sure that inverter charger is installed in an environment with relative humidity between 0% and 95% and no condensation.
-  If the inverter charger is installed improperly on a boat, it may cause damage to components of the boat. Have the inverter charger by a qualified electrician.
-  The inverter charger cannot operate at full load in ambient temperatures above 113°F (45°C).
-  The inverter charger should be as close to the battery as possible to avoid voltage drop due to long cables.
-  It is recommended that all cables (except communication cables) should not exceed 10 meters (32.8 feet) because excessively long cables result in a voltage drop. The communication cables should be shorter than 6 m (19.6 feet).
-  The cable specifications listed in the user manual account for critical, less than 3% voltage drop and may not account for all configurations.
-  Ensure the inverter charger is firmly grounded to a building, vehicle, or earth grounded. Keep the inverter charger away from EMI receptors such as TVs, radios, and other audio/visual electronics to prevent damage / interference to the equipment.



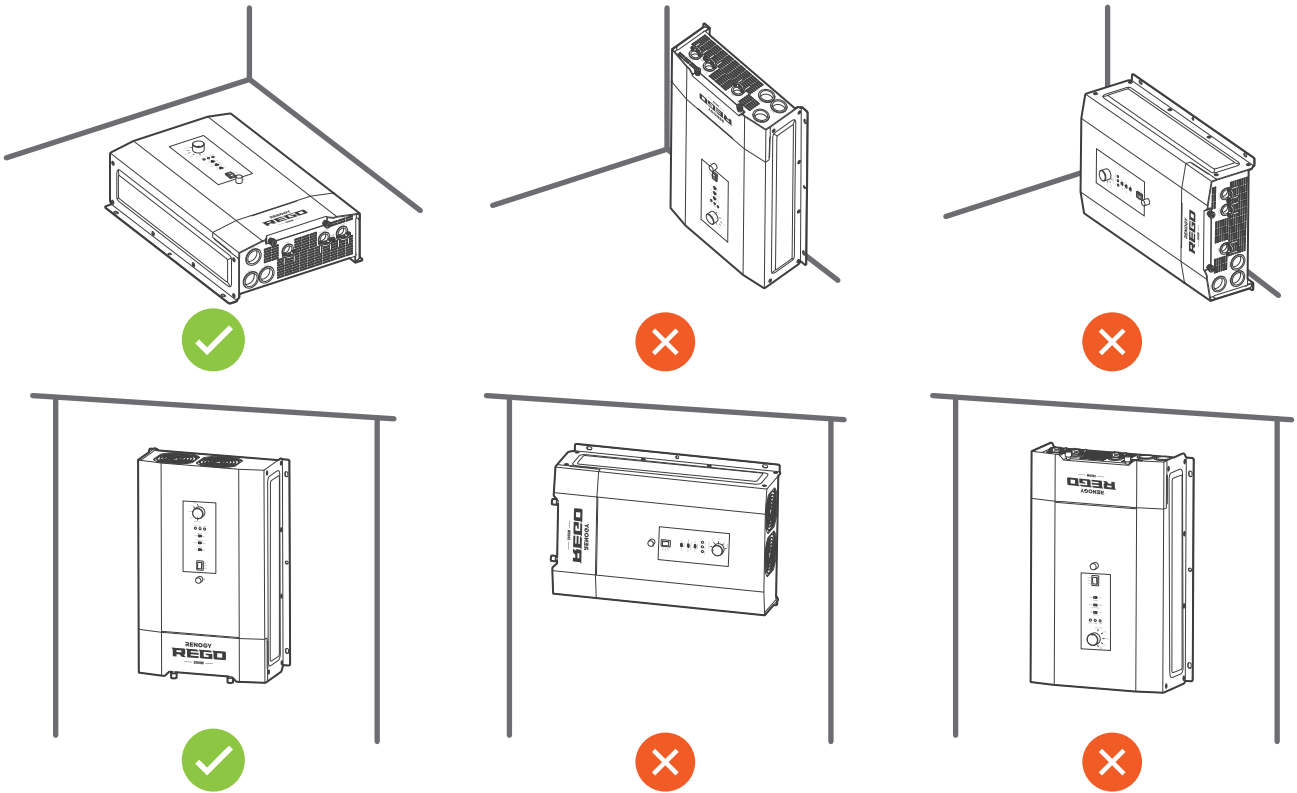

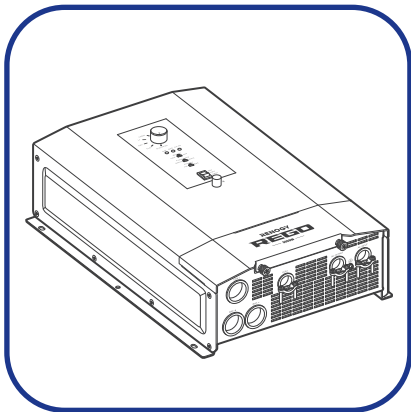

To ensure good ventilation and optimal system performance, we recommend mounting the inverter charger vertically (terminals down) on a wall or horizontally on the floor.



3.2. Check the Inverter Charger



1. Inspect the inverter charger for any visible damage including cracks, dents, deformation, and other visible abnormalities. All connector contacts shall be clean, free of dirt and corrosion, and dry.

-  Do not use the inverter charger if there is any visible damage.
-  Do not puncture, drop, crush, penetrate, shake, strike, or step on the inverter charger.
-  There are no serviceable parts in the inverter charger. Do not open, dismantle, repair, tamper with, or modify the inverter charger.
-  Confirm the polarities of the devices before connection. A reverse polarity contact can result in damage to the inverter charger and other connected devices, thus voiding the warranty.
-  Do not touch the connector contacts while the inverter charger is in operation.
-  Wear proper protective equipment and use insulated tools during installation and operation. Do not wear jewelry or other metal objects when working on or around the inverter charger.
-  Do not dispose of the inverter charger as household waste. Comply with local, state, and federal laws and regulations and use recycling channels as required.

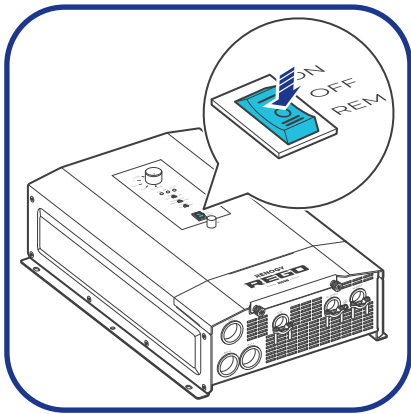

2. Ensure the On/Off/Remote Power Switch is in the OFF position.

3.3. Check the Battery

Recommended Components & Accessories

Battery Scenario A: REGO Battery Kit

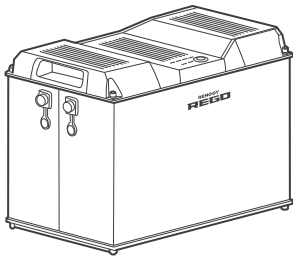

*REGO 12V 400Ah Lithium Iron Phosphate Battery

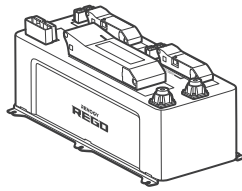

*REGO 4 Ports 400A System Combiner Box

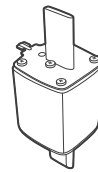

*NH2 Fuse (400A)

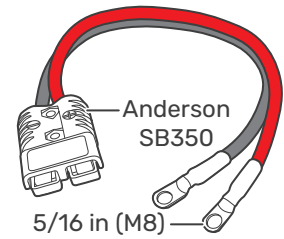

*Anderson Adapter Cable (4/0 AWG)

Battery Scenario B: Normal Battery Kit

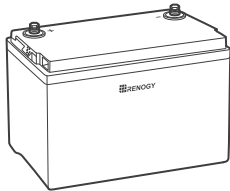

*12V Battery

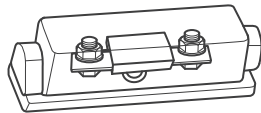

*ANL Fuse (400A)

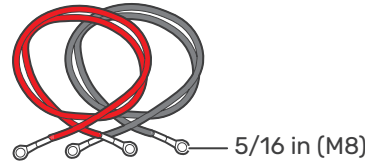

Battery Adapter Cables (4/0 AWG) x 2



Fuse Cable (4/0 AWG)





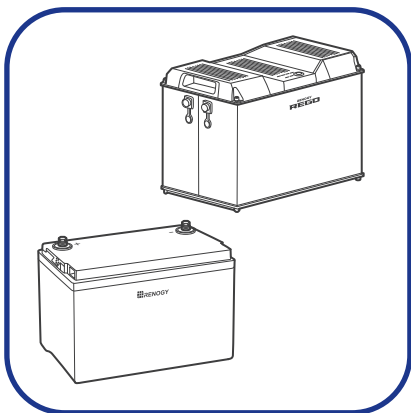

Components and accessories marked with "*" are available on renogy.com.



1. Inspect the battery for any visible damage including cracks, dents, deformation, and other visible abnormalities. All terminals shall be clean, free of dirt and corrosion, and dry.

The inverter charger can only be connected to deep-cycle gel-sealed lead-acid batteries (GEL), flooded lead-acid batteries (FLD), sealed lead-acid batteries (SLD/AGM) or lithium iron phosphate batteries (LI).

The inverter charger provides overcurrent protection by detecting the DC input current from the battery in real time. When the battery input reaches 400A, the inverter charger automatically shuts down the battery input to prevent damage caused by excessively high current.



-  Do not use the battery if there is any visible damage. Do not touch the exposed electrolyte or powder if the battery housing is damaged.
-  When being charged, the battery may give off explosive gas. Make sure there is good ventilation.
-  Take care to use a high-capacity lead-acid battery. Be sure to wear protective goggles. If carelessly getting electrolyte in your eyes, flush your eyes with clean water immediately.
-  Combine batteries in parallel or in series as needed. Prior to installing the inverter charger, ensure all battery groups are installed properly.
-  Read the user manual of the battery in use carefully.

Battery or Battery Bank System Voltage	
Battery or Battery Bank System Voltage = System Voltage U	
Batteries in Series	Batteries in Parallel
System Voltage U: $U_1+U_2+U_3$	System Voltage U: $U_1=U_2=U_3$

2. Check battery system voltage. This inverter charger supports a maximum system voltage of 17V. Read the user manual of the specific battery for battery voltage parameters, and calculate the voltage of the battery or battery pack system according to the formula to ensure that it does not exceed 17V.

The inverter charger operates normally at a range between 11V and 15.8V and allows a battery input from 9V to 17V with operating status specified below:

Battery Input Voltage	Inverter Charger Status	Solution
$9V < \text{Voltage} < 11V$	May fails to detect the battery	Charge the battery immediately
$11V \leq \text{Voltage} \leq 15.8V$	Operates normally	N/A
$15.8V < \text{Voltage} < 17V$	Trigger overvoltage alarm	Discharge the battery

-  Do not connect batteries rating higher than 17V to the inverter. Doing so will damage the inverter charger.
-  In the formula, U represents the battery voltage, and 1, 2 or 3 represents the battery number respectively.

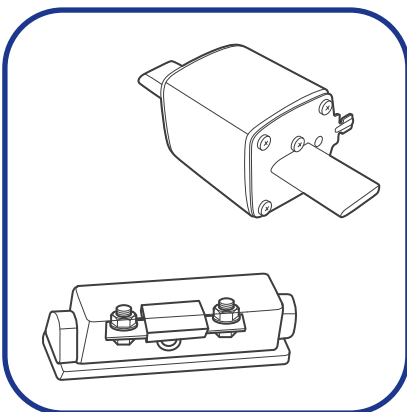

3. Inspect the NH2 Fuse or ANL Fuse for any visible damage including cracks, dents, deformation, and other visible abnormalities. All terminals shall be clean, free of dirt and corrosion, and dry.

-  Do not use the NH2 Fuse or ANL Fuse if there is any visible damage.

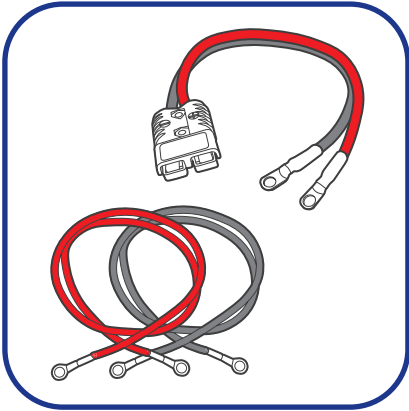

- Inspect the Anderson Adapter Cable or Battery Adapter Cables for any visible damage including cracks, dents, deformation, and other visible abnormalities. All connector contacts shall be clean, dry, and free of dirt and corrosion. All ring terminals are fastened to the cables.



Do not use the Anderson adapter cable or battery adapter cables if there is any visible damage.

3.4. Check the AC Loads (Appliances)

It works seamlessly with both 120V and 240V grid power systems and outputs 120V or 240V AC voltage in accordance with the AC input voltage. Choose proper accessories and cables based on the rated voltage of the connected AC loads (appliances).

AC Input Voltage	AC Output Voltage
Split-phase 120V/240V	120V/240V
Single-phase 120V	120V
0V (when grid power is unavailable)	120V

Recommended Components & Accessories

Recommended Cable Size	
Cable Length	Cable Size
0 ft to 10 ft	6 AWG
11 ft to 20 ft	4 to 6 AWG
21 ft to 30 ft	4 AWG

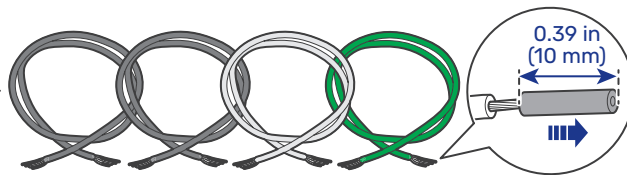

Bare Wires × 4

Recommended GFCI Spec	
Grid Power	Ratings
Unavailable	≥25A@120V
Available	≥50A@120V
	≥25A@240V

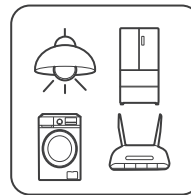
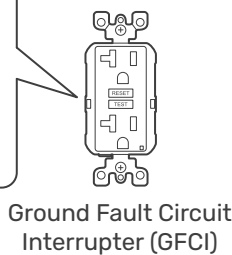



Total Load Power	
Grid Power	Ratings
Unavailable	≤3000W @120V
Available	≤6000W @120V/240V

A ground fault circuit interrupter, or GFCI, is a device that helps protect people from electric shock by de-energizing a circuit or part of a circuit within a specified time if a current to ground exceeds a predetermined value that is less than that required to operate the overcurrent device (circuit breaker or fuse) on the service circuit. GFCIs are typically required in wet or damp locations.



The following table lists GFCIs that meet specifications and will function properly when connected to the AC Outlets of the inverter charger.

Tested GFCI Models	Manufacturer	Model Number
	Cooper Wiring Devices	SGF20
	Leviton Mfg Co Inc	GFNT2
	Hubbell Inc Wiring Device Dev	GFRST20
	Pass & Seymour Inc	2097

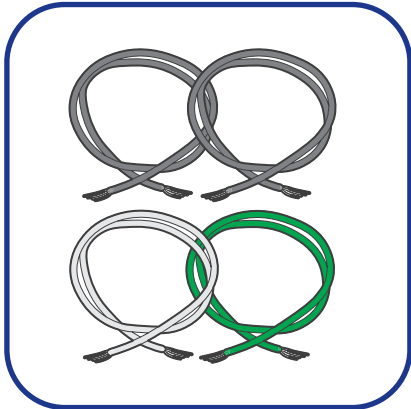
-  Risk of electrical shock. Use only ground-fault circuit interrupters [receptacle(s) or circuit breaker(s)] compatible with your inverter charger.
-  GFCIs shall be installed in a recreational vehicle's wiring system to protect all branch circuits.
-  For details on how to connect loads and the inverter charger to the GFCI, read the user manual of the specific GFCI.



Inspect the Bare Wires for any visible damage including cracks, dents, deformation, and other visible abnormalities. All connector contacts shall be clean, dry, and free of dirt and corrosion.

-  Do not use the bare wires if there is any visible damage.
-  The AC Output Port has an inner diameter of 0.79 in (20 mm). Properly select the AC cable size and ensure that four bare wires can run through the grommet at the same time.



3.5. Check the AC Generator or the Grid (Optional)

Recommended Components & Accessories

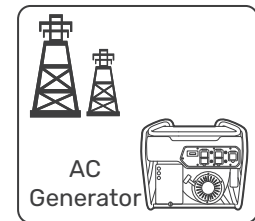
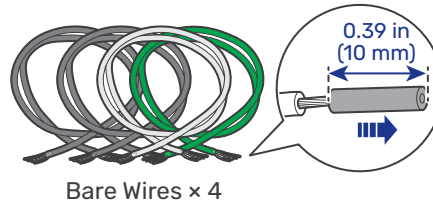
Recommended Cable Size	
Cable Length	Cable Size
0 ft to 10 ft	6 AWG
11 ft to 20 ft	4 to 6 AWG
21 ft to 30 ft	4 AWG



AC Generator
Grid Power
(Single-phase 120V or Split-phase 120V/240V)

-  Risk of electric shock! Ensure the grid or the AC generator is turned off before connecting them to the inverter charger.
-  Read the user manual of the AC generator before the installation.
-  The AC Input Port has an inner diameter of 0.79 in (20 mm). Properly select the AC cable size and ensure that four bare wires can run through the grommet at the same time.

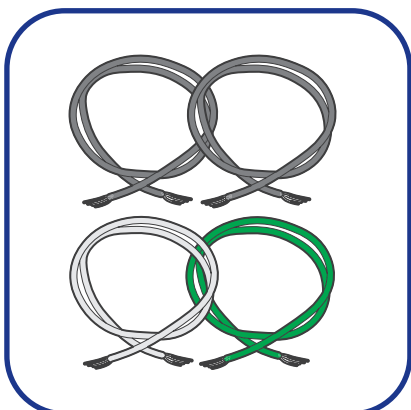

Inspect the Bare Wires for any visible damage including cracks, dents, deformation, and other visible abnormalities. All connector contacts shall be clean, dry, and free of dirt and corrosion.

 Do not use the bare wires if there is any visible damage.

3.6. How to Properly Install Cable Clamps?

The AC Input Port, AC Output Port, and COM Port are equipped with cable clamps to ensure that the wiring connections remain secure and do not come loose due to vibrations.

Step 1: Loosen the screws on a cable clamp with a Phillips Screwdriver.

Step 2: Lift the clamp, and run the cables through the clamp.

Step 3: Secure the clamp by fastening the screws.

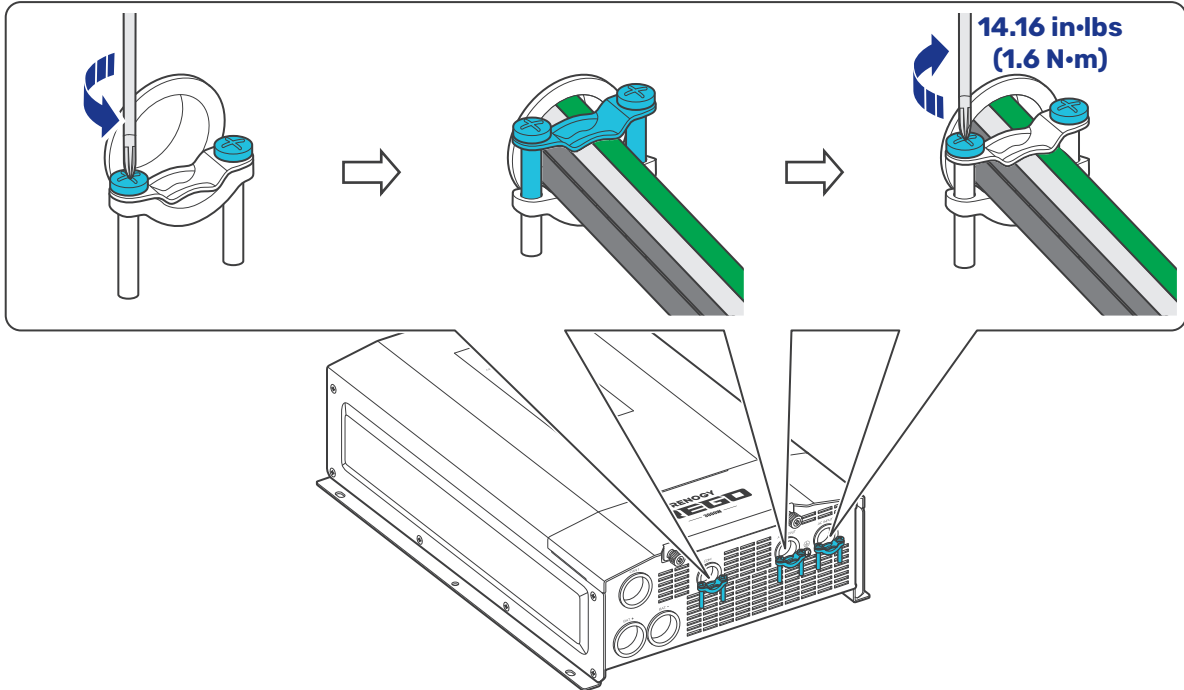

 The screw torque of a cable clamp is 14.16 in·lbs (1.6 N·m). Do not overtighten the screws to prevent damage.

4. Installation

4.1. Wear Insulating Gloves

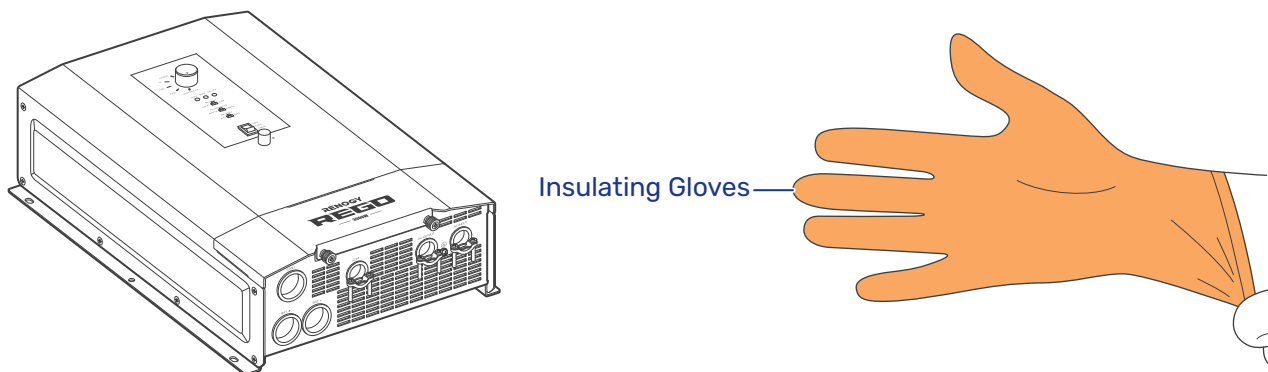

4.2. Mount the Inverter Charger

Secure the inverter charger to the installation site by fixing self-tapping screws through the mounting holes.

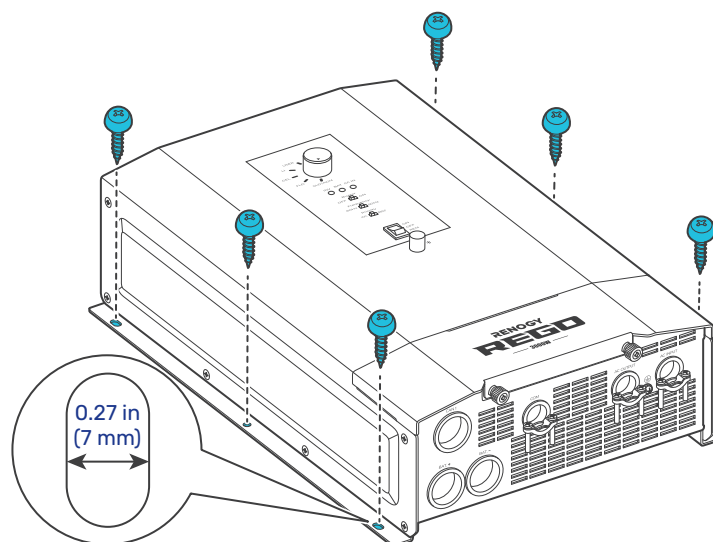

i Make sure that the inverter charger is installed firmly to prevent it from falling off.

4.3. Remove the Cover

Step 1: Turn the two Cover Screws counterclockwise either by hand or by using a Phillips screwdriver.

Step 2: Remove the Cover.

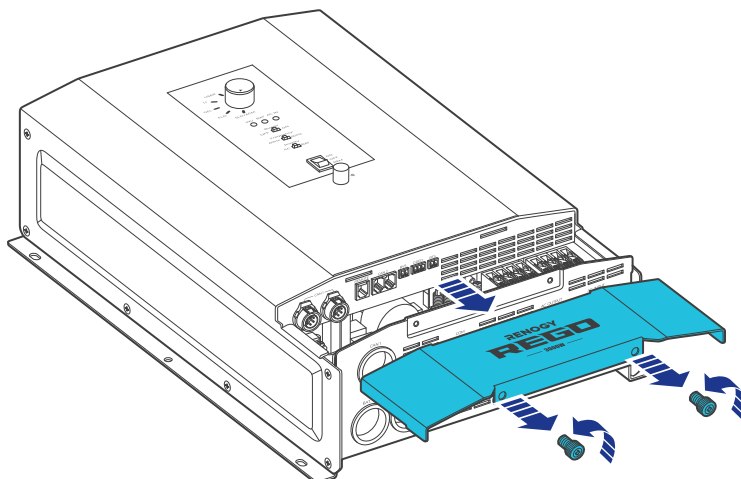

4.4. Ground the Inverter Charger

Recommended Components

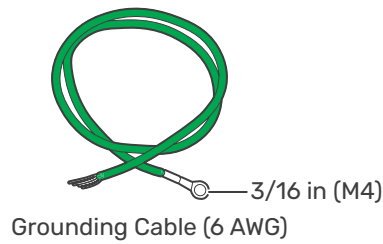

Step 1: Remove the screw on the Ground Port with a Phillips Screwdriver.

Step 2: Connect the Grounding Cable Ring Terminal to the grounding port of the inverter charger with the removed screw by using the Phillips Screwdriver.

Step 3: Connect the bare wire end of the grounding cable to a grounding rod (not included), if applicable.

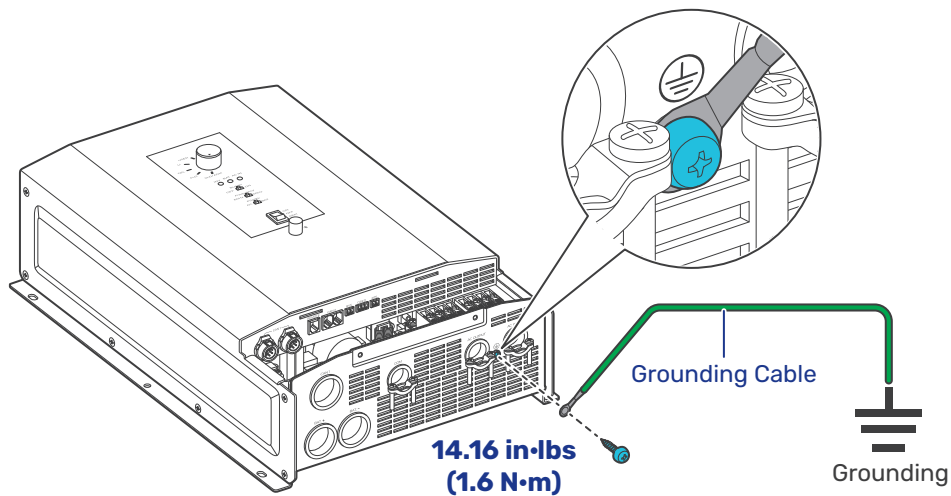

- i** When the GFCI fails to operate normally after grounding the inverter charger, please refer to “[5.1. N-G Bonding Relay](#)” for details.
- i** The screw torque of a cable clamp is 14.16 in·lbs (1.6 N·m). Do not overtighten the screws to prevent damage.
- i** The DC Grounding system is sometimes referred to as the earth ground or another designated ground. In an RV Setting, the metal frame of the RV could be the designated ground. A common ground should be used to bond the inverter charger, negative bus bar, and negative battery terminal together, if applicable.

4.5. Install a Wired Remote Control

You can use a Wired Remote Control to power on or off the inverter charger remotely.

Step 1: Run the RJ12 Cable through the grommet of the COM Port.

Step 2: Connect the RJ12 connector to the Wired Remote Port on the inverter charger.

Step 3: Connect the other end of the cable to the Wired Remote Control.

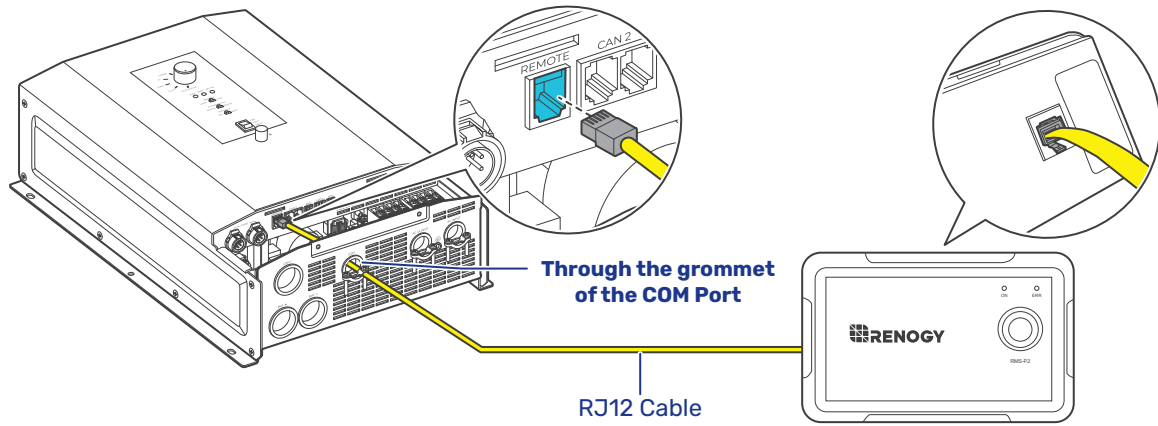

4.6. Install a Battery Voltage Sensor

The Battery Voltage Sensor measures the battery voltage during discharging and compensates for any voltage drop across the cables at the battery terminal. This helps minimize the impact on the battery's operational voltage.

■ Battery Scenario A: REGO Battery Kit

Step 1: Run the Battery Voltage Sensor cable through the grommet of the COM Port.

Step 2: Connect the terminal block to the Battery Voltage Sensor (BVS) Port on the inverter charger.

Step 3: Connect the Negative Ring Terminal of the Battery Voltage Sensor to the Negative Insert Terminal on the REGO 4 Ports 400A System Combiner Box.

Step 4: Connect the Positive Ring Terminal of the Battery Voltage Sensor to the Positive Insert Terminal on the REGO 4 Ports 400A System Combiner Box.

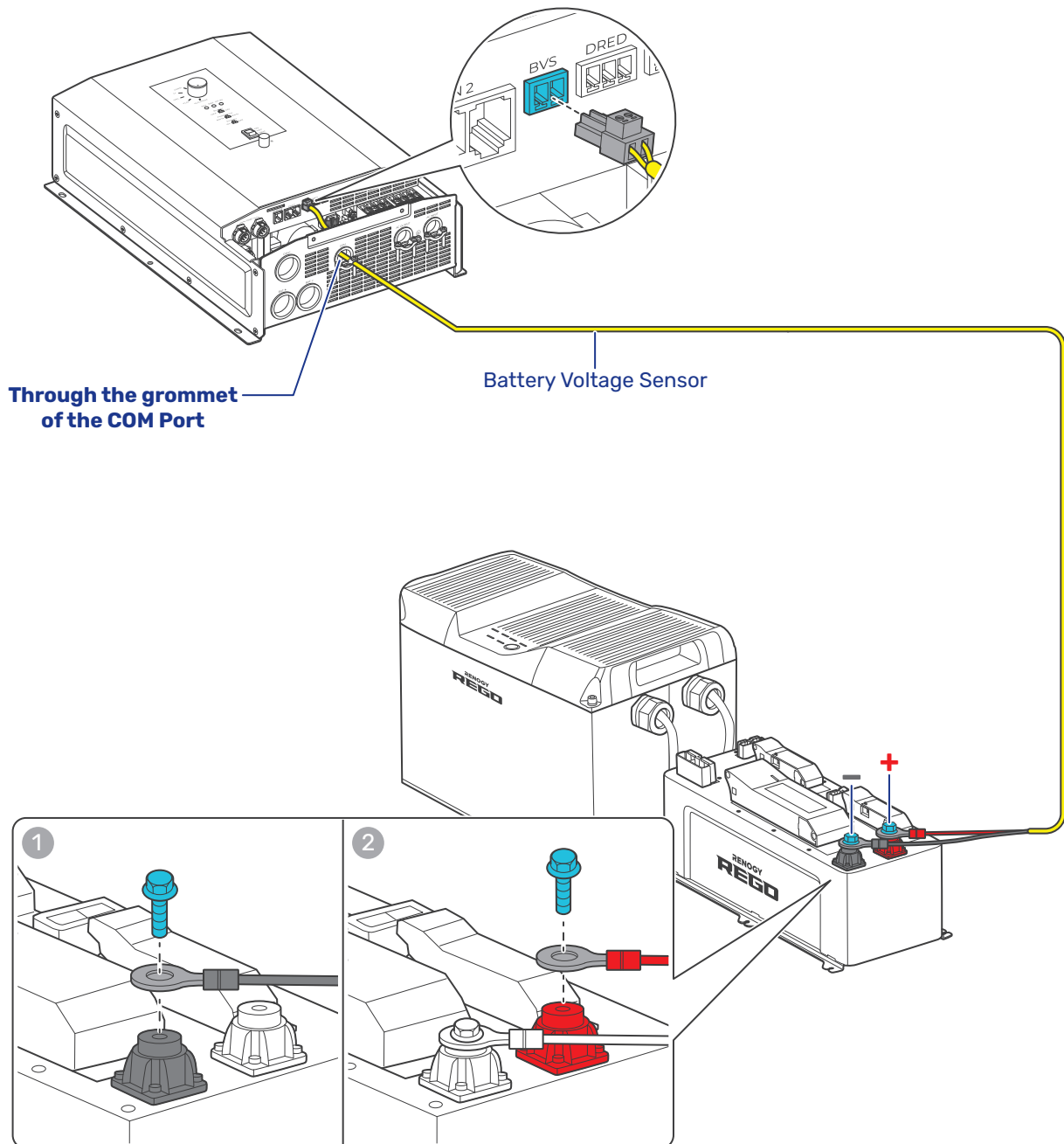

■ Battery Scenario B: Normal Battery Kit

Step 1: Run the Battery Voltage Sensor cable through the grommet of the COM Port.

Step 2: Connect the terminal block to the Battery Voltage Sensor (BVS) Port on the inverter charger.

Step 3: Connect the Negative Ring Terminal of the Battery Voltage Sensor to the Negative Terminal on the 12V battery.

Step 4: Connect the Positive Ring Terminal of the Battery Voltage Sensor to the Positive Terminal on the 12V battery.

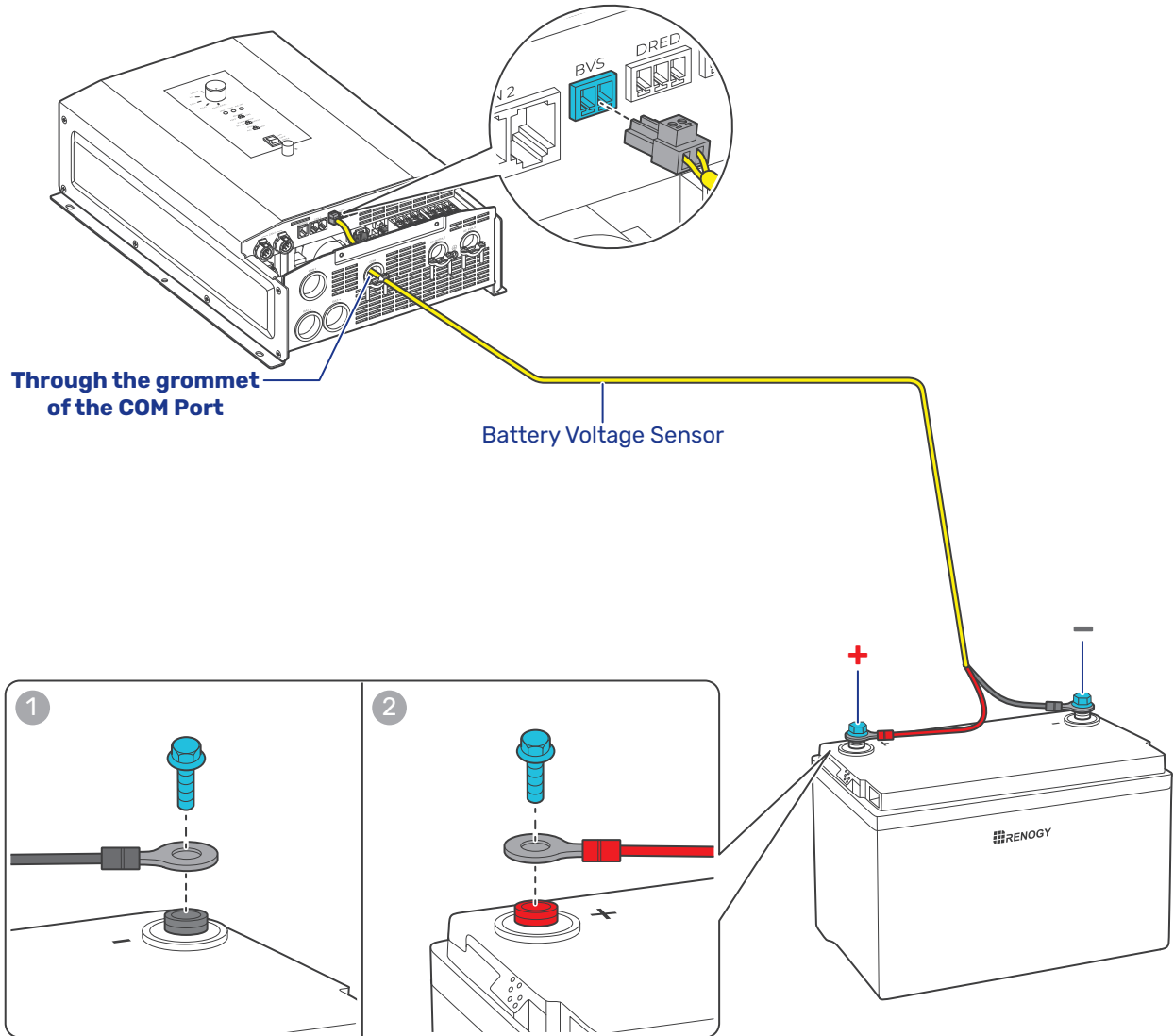

4.7. Install a Battery Temperature Sensor

The temperature sensor measures the surrounding temperature of the battery and compensates the floating charge voltage when the battery temperature is low.

i Do not use the temperature sensor on a LiFePO4 (LFP) battery which comes with a battery management system (BMS).

Step 1: Run the Battery Temperature Sensor cable through the grommet of the COM Port.

Step 2: Connect the terminal block to the Battery Temperature Sensor (BTS) Port on the inverter charger.

Step 3: Mount the sensor securely at a suitable location in close proximity to the battery.

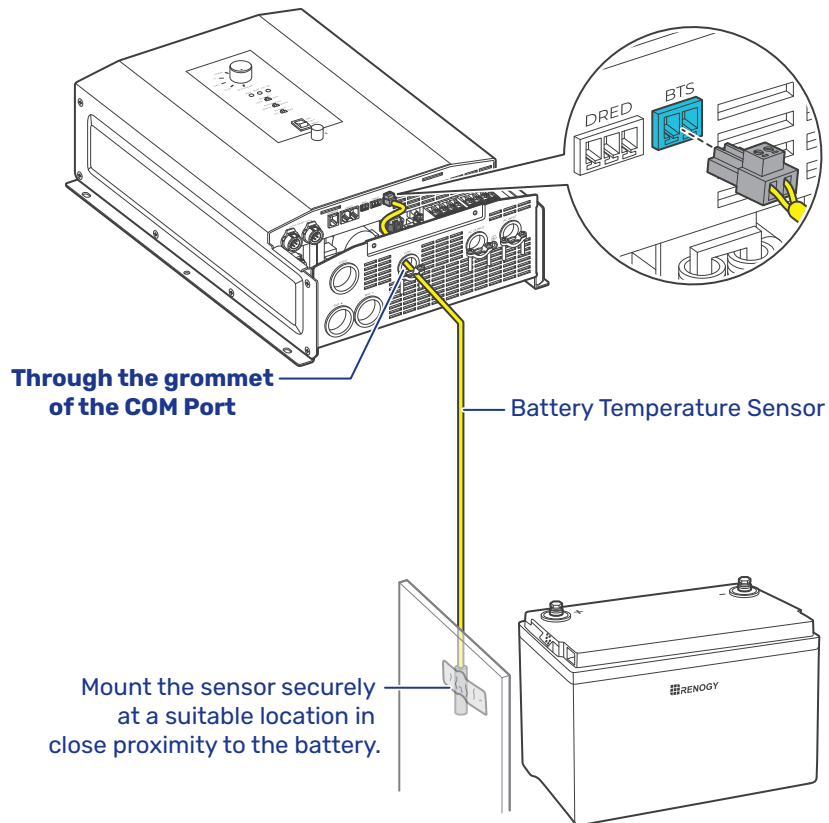

i Never mount the temperature sensor on the battery to prevent false overtemperature alarms.

4.8. Connect the Inverter Charger to a Battery

Battery Scenario A: REGO Battery Kit

Step 1: Remove the retaining nut from the Battery Negative Terminal on the inverter charger by using a Socket Wrench. Run the negative lug (in black) of the Anderson Adapter Cable through the grommet of the Battery Negative Port, and connect the negative lug to the Battery Negative Terminal with the retaining nut.

Step 2: Repeat the actions on the Battery Positive Terminal on the inverter charger to finish connection on the positive end.

Step 3: Lift the operating handle to open the cover of the REGO 4 Ports 400A System Combiner Box NH2 Fuse Switch Disconnecter, press and hold the release tab on the inside of the cover, locate the slots on the inside of the cover, slide the gripping lugs of the NH2 Fuses into the slots, and release the release tab.

Ensure the NH2 Fuse is installed tightly prior to closing the cover of the NH2 Fuse Switch Disconnecter.

Press the cover firmly to ensure that the NH2 Fuse is engaged.

Step 4: Insert the Anderson SB350 connectors to the Anderson 350 Connector (Inverter) on the REGO 4 Ports 400A System Combiner Box.



The retaining nut torque of the Battery Positive/Negative Terminal is 70.8 in·lbs (8 N·m). Do not overtighten it to prevent damage.

STEP-1 Install the Cable on the Inverter Charger

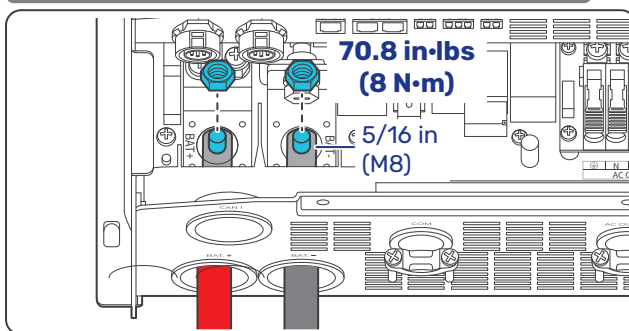

Through the grommet of the Battery Positive Port and Battery Negative Port

STEP-2 Install an NH2 Fuse

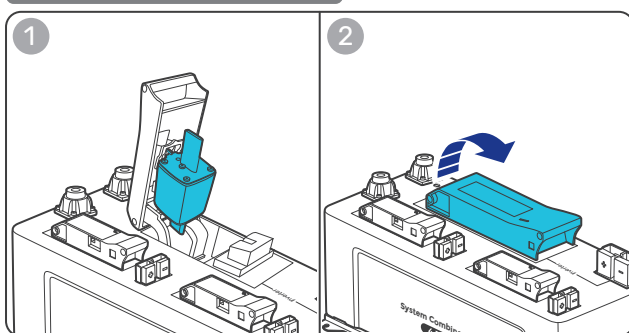

STEP-3 Install the Cable on the System Combiner Box

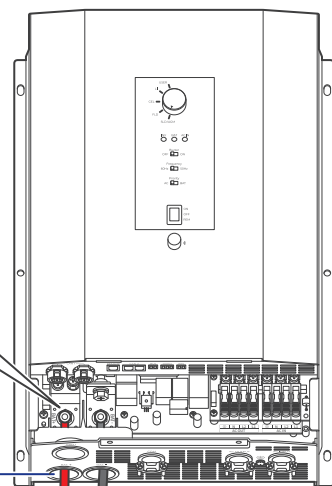
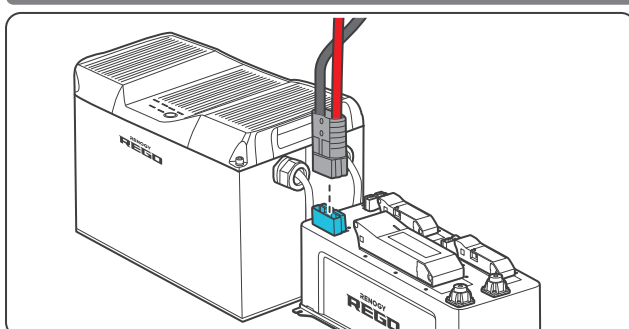

Anderson
Adapter
Cable

Battery Scenario B: Normal Battery Kit

- Step 1:** Remove the retaining nut from the Battery Negative Terminal on the inverter charger by using a Socket Wrench. Run the Negative Battery Adapter Cable through the grommet of the Battery Negative Port of the inverter charger, and connect the ring terminal of the Negative Battery Adapter Cable to the Battery Negative Terminal with the retaining nut.
- Step 2:** Connect the other ring terminal of Negative Battery Adapter Cable to the negative terminal of the battery.
- Step 3:** Repeat the actions in Step 1 on the Battery Positive Terminal on the inverter charger to finish connection on the positive end.
- Step 4:** Remove the retaining nuts from the ANL Fuse, connect the Positive Battery Adapter Cable to one end of the ANL Fuse, and fix them with one retaining nut.
- Step 5:** Connect the ANL Fuse to the positive terminal of the battery via the Fuse Cable, and fix the fuse cable on the ANL Fuse with the other retaining nut.

i The retaining nut torque of the Battery Positive/Negative Terminal is 70.8 in·lbs (8 N·m). Do not overtighten it to prevent damage.

STEP-1 Install the Cables on the Inverter Charger

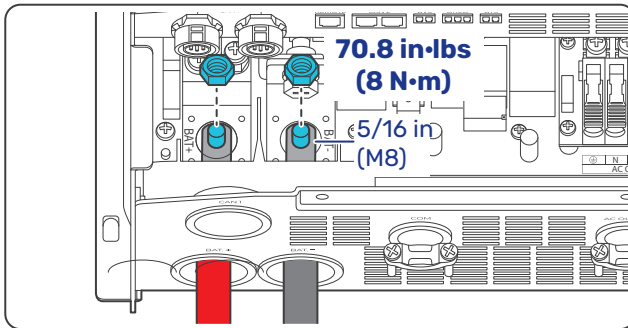

Through the grommet of the Battery Positive Port and Battery Negative Port

STEP-2 Install an ANL Fuse

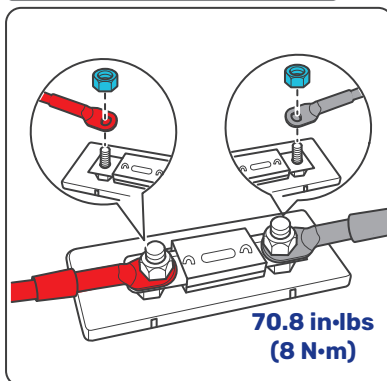

STEP-3 Install the Cables on the Battery

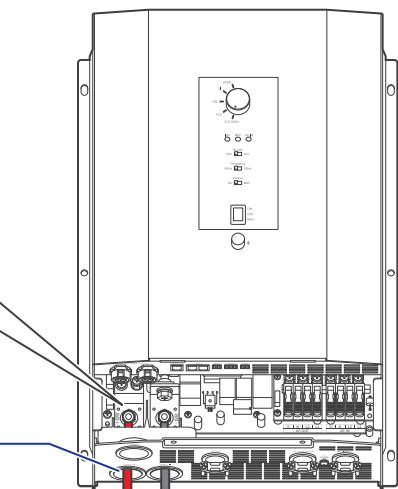
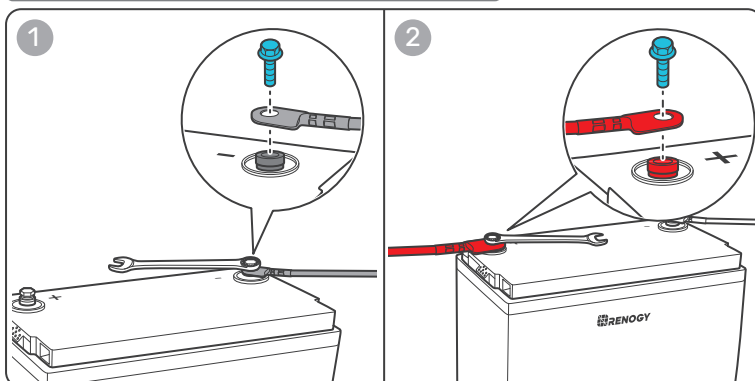

Battery Adapter Cables

ANL Fuse (400A)

Fuse Cable

12V Battery

4.9. Connect the Inverter Charger to AC Loads (Appliances)

For split-phase 120V/240V grid systems where AC IN L1, L2, and N are used:

- When the AC output is connected to L1, L2, and N, the inverter charger outputs 240V.
- When the AC output is connected to L1 and N, the inverter charger outputs 120V.

For single-phase 120V grid systems or when there is no available grid power, the inverter charger outputs 120V.

■ Single-phase 120V

Step 1: Strip some insulation (0.39 in/10 mm) off each of the three bare wires with a wire stripper, and run the three bare wires through the grommet of the AC Output Port on the inverter charger.

Step 2: Push up the switches of the wire harness retainer of the AC Output Terminals.

Step 3: Connect the bare wires to the live (L1), neutral (N) and ground (⊕) terminals respectively on the inverter charger.

Step 4: Locate the live, neutral, and ground terminals on the GFCI, and connect the other ends of the bare wires to the respective terminals on the GFCI. The L1 terminal of the inverter charger should be connected to the live terminal on the GFCI. The same rules apply to the neutral and ground terminals.

Step 5: To ensure optimal performance of the inverter charger, it is recommended that the GFCI should be connected to AC loads after the inverter charger is securely powered on with necessary wiring completed.

STEP-1 Install Bare Wires on the Inverter Charger

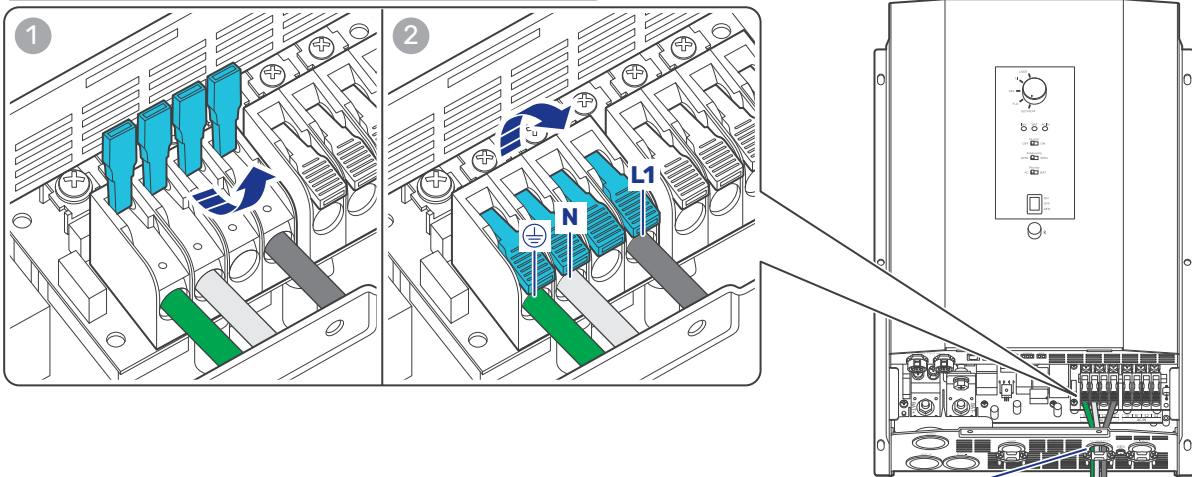

Through the grommet of the AC Output Port

Bare Wires

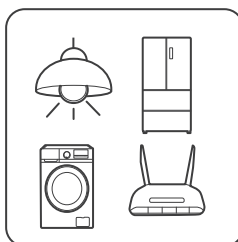

AC Loads (120V)

STEP-2 Install a GFCI

120V Output

i Tug on bare wires to ensure firm connection.

i For details on how to connect loads and the inverter charger to the GFCI, read the user manual of the specific GFCI.

Split-phase 120V/240V

120V output wiring:

- Step 1:** Strip some insulation (0.39 in/10 mm) off each of the three bare wires with a wire stripper, and run the three bare wires through the grommet of the AC Output Port on the inverter charger.
- Step 2:** Push up the switches of the wire harness retainer of the AC Output Terminals.
- Step 3:** Connect the bare wires to the live (L1), neutral (N) and ground (⊕) terminals respectively on the inverter charger.
- Step 4:** Locate the live, neutral, and ground terminals on the GFCI, and connect the other ends of the bare wires to the respective terminals on the GFCI. The L1 terminal of the inverter charger should be connected to the live terminal on the GFCI. The same rules apply to the neutral and ground terminals.
- Step 5:** To ensure optimal performance of the inverter charger, it is recommended that the GFCI should be connected to AC loads after the inverter charger is securely powered on with necessary wiring completed.

STEP-1 Install Bare Wires on the Inverter Charger

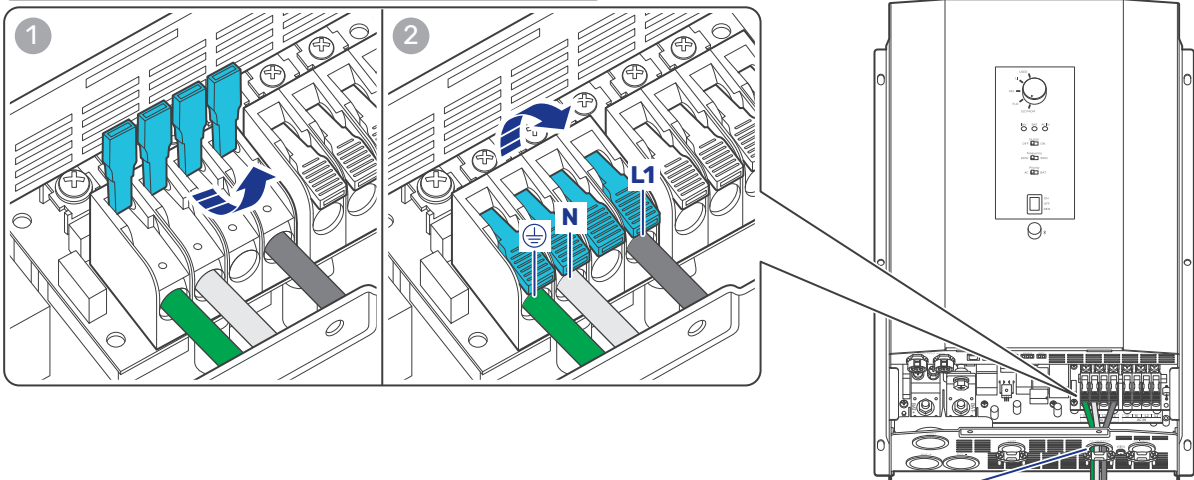

Through the grommet of the AC Output Port

Bare Wires

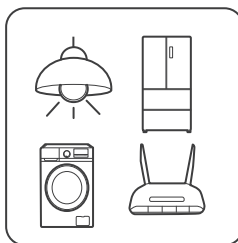

STEP-2 Install a GFCI

120V Output

- i** Tug on bare wires to ensure firm connection.
- i** For details on how to connect loads and the inverter charger to the GFCI, read the user manual of the specific GFCI.

240V output wiring:

Step 1: Strip some insulation (0.39 in/10 mm) off each of the four bare wires with a wire stripper, and run the four bare wires through the grommet of the AC Output Port on the inverter charger.

Step 2: Push up the switches of the wire harness retainer of the AC Output Terminals.

Step 3: Connect the bare wires to the live (L1 and L2), neutral (N) and ground (⊕) terminals respectively on the inverter charger.

Step 4: Locate the live, neutral, and ground terminals on the GFCI, and connect the other ends of the bare wires to the respective terminals on the GFCI. The L1 and L2 terminals of the inverter charger should be connected to the live terminal on the GFCI. The same rules apply to the neutral and ground terminals.

Step 5: To ensure optimal performance of the inverter charger, it is recommended that the GFCI should be connected to AC loads after the inverter charger is securely powered on with necessary wiring completed.

STEP-1 Install Bare Wires on the Inverter Charger



Through the grommet of the AC Output Port

Bare Wires

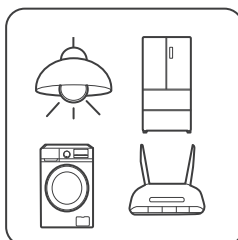

AC Loads (240V)

STEP-2 Install a GFCI

240V Output

i Tug on bare wires to ensure firm connection.

i For details on how to connect loads and the inverter charger to the GFCI, read the user manual of the specific GFCI.

4.10. Connect the Inverter Charger to the Grid

The connection of AC IN ports vary depending on the connected grid systems. For single-phase 120V grid systems, only AC IN L1 and N ports are used for the input. For split-phase 120V/240V grid systems, AC IN L1, L2, and N ports are used for the input.



Do not parallel the inverter charger with other AC input sources to avoid damage.



The inverter charger provides overcurrent protection by detecting the AC input current from the grid or a generator in real time. When the AC input reaches 30A, the inverter charger automatically shuts down the AC input to prevent damage caused by excessively high current. You can customize the overcurrent protection threshold on the DC Home app. Maximum allowed threshold: 50A.

■ Single-phase 120V

Step 1: Strip some insulation (0.39 in/10 mm) off each of the three bare wires with a wire stripper, and run the three bare wires through the grommet of the AC Input Port on the inverter charger.

Step 2: Push up the switches of the wire harness retainer of the AC Input Terminals.

Step 3: Connect the bare wires to the live (L1), neutral (N) and ground (⊕) terminals respectively on the inverter charger.

Step 4: Locate the live, neutral, and ground terminals on the grid, and connect the other ends of the bare wires to the respective terminals on the grid. The L1 terminal of the inverter charger should be connected to the live terminal on the grid. The same rules apply to the neutral and ground terminals.

STEP-1 Install Bare Wires on the Inverter Charger

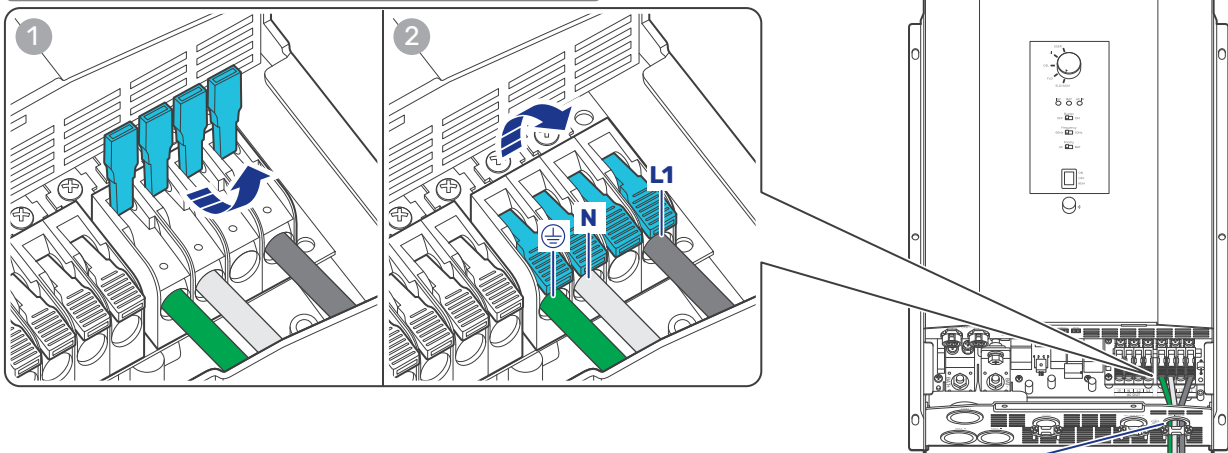

Through the grommet of the AC Input Port

Bare Wires

120V Input

STEP-2 Install Bare Wires on the Grid

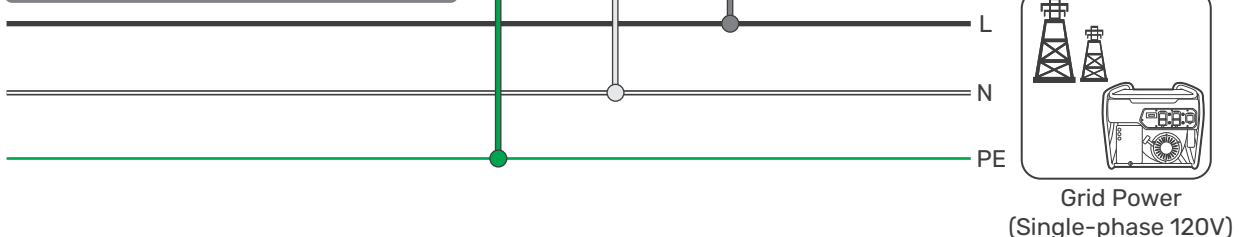

Tug on bare wires to ensure firm connection.

If there is no available grid contact, connect the ground bare wire (one end connecting to \oplus) to the N bare wire as shown in the figure below. Failure to follow this step may result in charging/discharging issues with grid power, along with fault alarms.

STEP-1 Install Bare Wires on the Inverter Charger

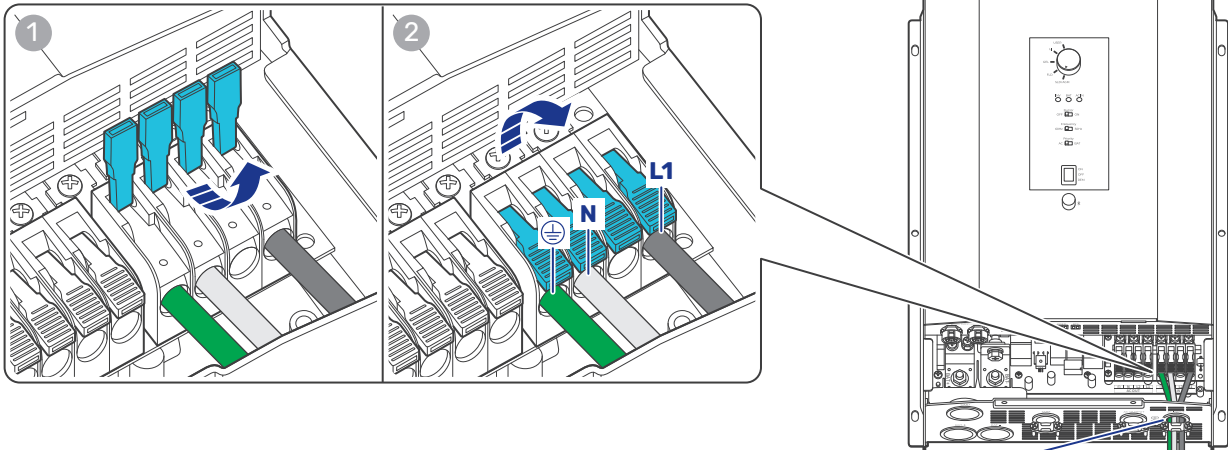

Through the grommet of the AC Input Port

Bare Wires

120V Input

STEP-2 Install Bare Wires on the Grid

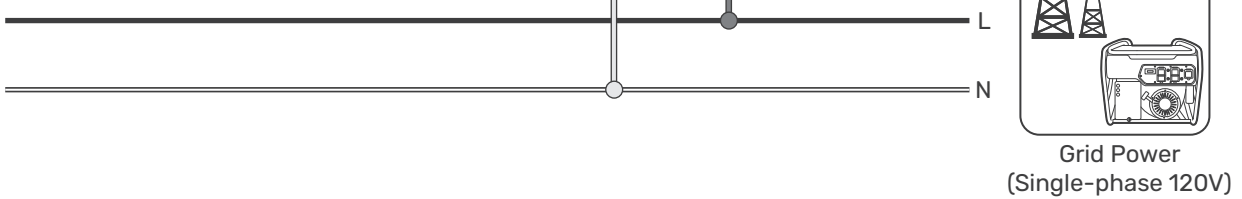

Split-phase 120V/240V

Step 1: Strip some insulation (0.39 in/10 mm) off each of the four bare wires with a wire stripper, and run the four bare wires through the grommet of the AC Input Port on the inverter charger.

Step 2: Push up the switches of the wire harness retainer of the AC Input Terminals.

Step 3: Connect the bare wires to the live (L1 and L2), neutral (N) and ground (⊕) terminals respectively on the inverter charger.

Step 4: Locate the live, neutral, and ground terminals on the grid, and connect the other ends of the bare wires to the respective terminals on the grid. The L1 terminal of the inverter charger should be connected to the live terminal (L1) on the grid. The same rules apply to the L2, neutral, and ground terminals.

STEP-1 Install Bare Wires on the Inverter Charger

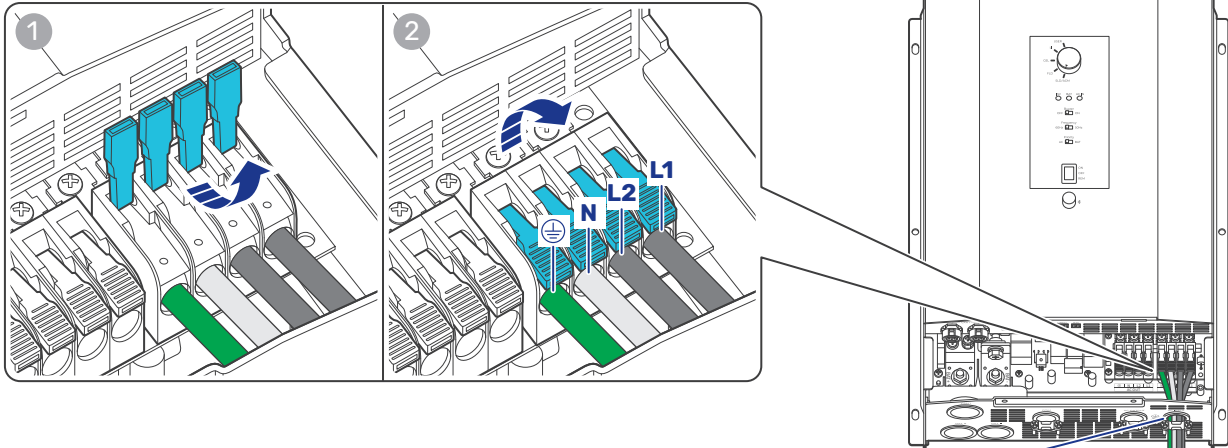

Through the grommet of the AC Input Port

Bare Wires

STEP-2 Install Bare Wires on the Grid

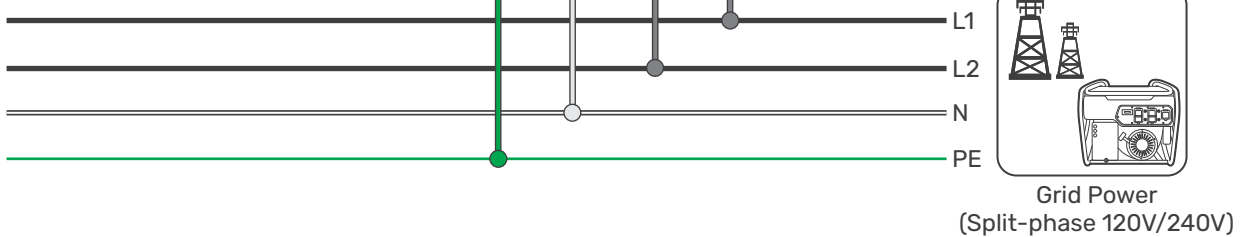

Tug on bare wires to ensure firm connection.

If there is no available grid contact, connect the ground bare wire (one end connecting to \oplus) to the N bare wire as shown in the figure below. Failure to follow this step may result in charging/discharging issues with grid power, along with fault alarms.

STEP-1 Install Bare Wires on the Inverter Charger

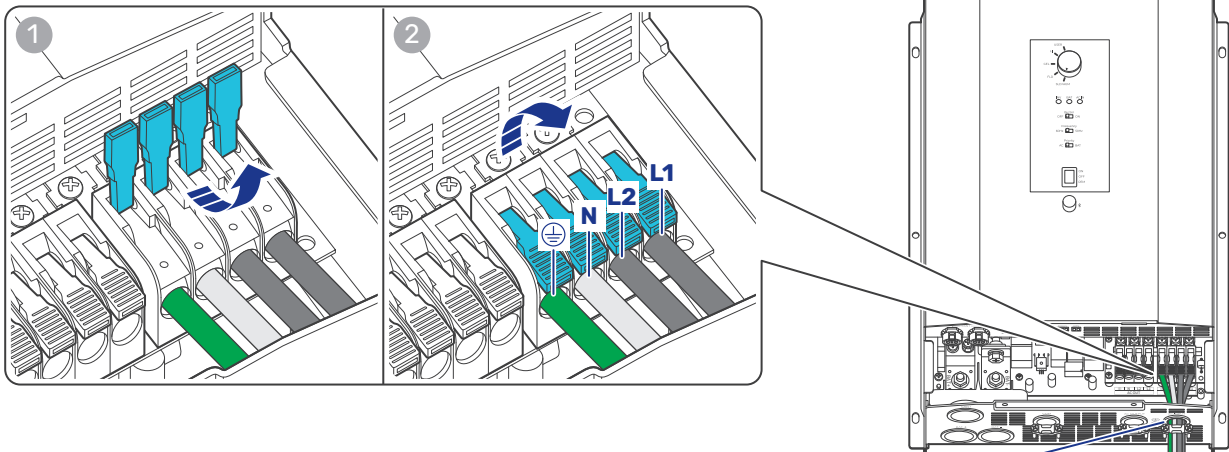

Through the grommet of the AC Input Port

Bare Wires

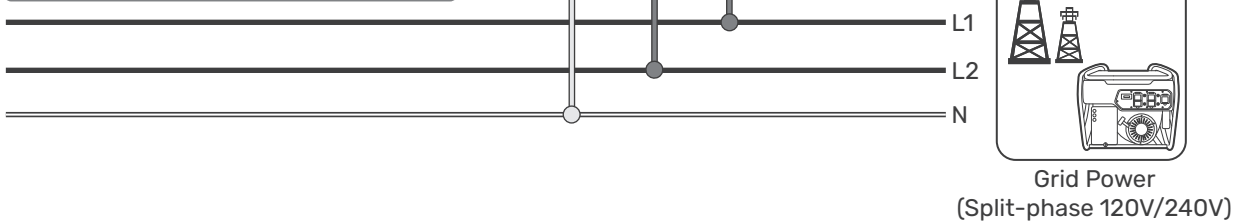

STEP-2 Install Bare Wires on the Grid



Grid Power
(Split-phase 120V/240V)

Automatic Generator Start

For AC Generators supporting the automatic on/off function, connect the generator to the inverter charger. If the battery voltage reaches or falls below the Low Voltage Reconnect value (when a Battery Voltage Sensor are involved), the inverter charger will send a 5-minute start signal to the generator. Upon receiving the signal, the generator will automatically start and provide power to the battery and loads.

-  Read the user manual of the AC Input source carefully before connection.
-  Make sure the generator can automatically start or stop. Identify NC (normally closed contact), NO (normally open contact), and C (common static contact) of the generator and ensure signal lines are connected properly. Some generators only have NC and C (common static contact) or NO and C. You can connect them on demand.
-  Do not install the inverter charger near any generator supporting automatic generator on/off because these generators exhaust dangerous fumes in operation.

Recommended Accessories

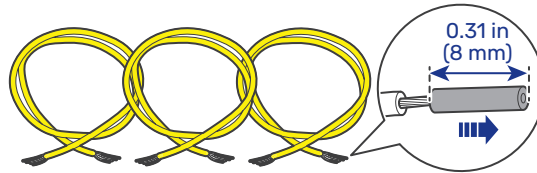

Bare Wires × 3

i There is no polarity requirement for the bare wires.

Step 1: Strip some insulation (0.31 in/8 mm) off each of the three bare wires with a wire stripper, and run the three bare wires through the grommet of the COM Port on the inverter charger.

Step 2: Turn the cable retainer screws of NC, C and NO of Dry Contact Relay Connector counterclockwise with a slotted screwdriver to ensure that the cable retainers are open.

Step 3: Connect the three bare wires to the corresponding NC, C, and NO wiring holes.

Step 4: Turn the cable retainer screws of NC, C and NO clockwise with a slotted screwdriver to fasten the cable.

Step 5: Connect the Dry Contact Relay Connector to the Dry Contact Port (DRED) on the inverter charger.

Step 6: Connect the bare ends of the three wires to the AC generator.

i For details on how to connect the AC Generator to the inverter charger, read the user manual of the specific generator.

STEP-1 Install Bare Wires on the Inverter Charger

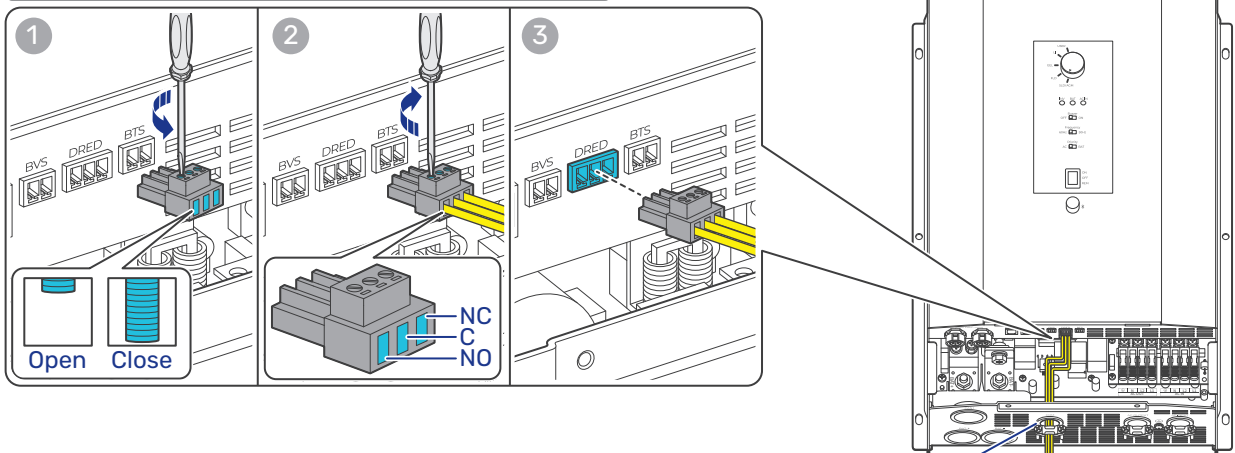

Through the grommet of the COM Port

STEP-2 Install Bare Wires on the AC Generator

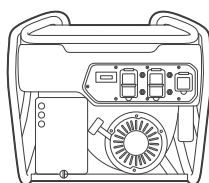

AC Generator

NO
C
NC

Bare Wires

4.11. CAN Communication Wiring (Optional)

The REGO 12V 3000W HF Inverter Charger can communicate with other REGO devices and monitoring devices, enabling safe operation, smart control, remote monitoring, and programmable settings.

You can connect the inverter charger to other REGO devices for real-time inter-device data communication through any of the CAN1 Port.

The wiring details vary depending on the wiring schemes. This user manual elaborates on inter-device wiring in two schemes: backbone and daisy chain.

i For technical support from Renogy, please contact us through renogy.com/contact-us/.

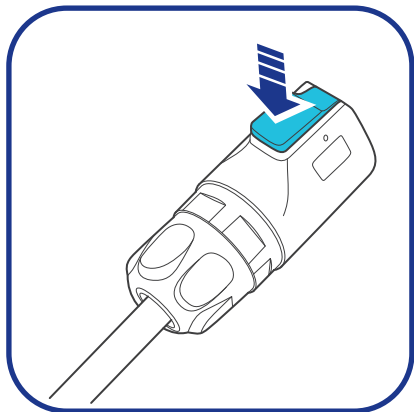

To properly connect or disconnect the LP16 Terminal Plug to or from the inverter charger, you should

1. Ensure that the plug is oriented vertically toward the CAN1 Communication Port.
2. Press and hold the snap until the process is complete.

Shaking while plugging or unplugging is not allowed.

■ Backbone Network

Ensure 120Ω terminating resistors are installed at both ends of the RV-C bus for successful communication with REGO series devices. If the RV user manual does not determine if the RV-C bus has a built-in 120Ω termination resistor, call the RV manufacturer to confirm.

i If the RV-C bus does not have a built-in 120Ω termination resistor, the inverter charger will not communicate properly with other REGO series devices. Please use the Daisy Chain Network for communication connections.

Connect devices to the inverter charger according to the wiring diagram provided by the RV manufacturer. Choose proper communication cables according to your specific demands.

Recommended Tools & Accessories

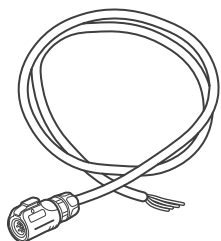

LP16 Plug (7-Pin) to Bare Drop Cable(s)

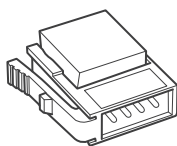

Drop Plugs

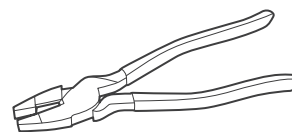

Split Joint Pliers

i The drop cable shall not exceed 19.6 feet (6 m), and the RV-C bus shall not exceed 98.4 feet (30 m).

i Choose the appropriate drop plugs that are compatible with the drop sockets used on the RV-C bus. Different RV manufacturers may use different types of drop sockets for inter-device communication connections. If you are unsure about the correct drop plug selection, consult with the RV manufacturer. In this quick guide, the Mini-Clamp II plug (4-pin) is used as an example.

i Different Drop Plugs follow different pinouts. Crimp the Drop Plugs on the Drop Cables following the correct pinout. If you are not sure about the Drop Plug pinout, check with the RV manufacturer.

Step 1: Install the Drop Plugs on the bare end of the LP16 Plug (7-Pin) to Bare Drop Cable. The green CAN_H wire goes to pin 2, the orange CAN_L wire goes to pin 3. Leave pin 1 and pin 4 empty.

Step 2: Squeeze the crimp areas of the Drop Plugs with the Split Joint Pliers.

Step 3: Locate the drop tap (not included) on the RV-C bus that is the closest to the installation site of the inverter charger. The drop taps are usually located above the entry door, in the bathroom, or under the bed in the RV.

Step 4: Connect the Drop Plugs on the drop cables and other REGO devices to the drop sockets on the drop tap.

Step 5: Run the LP16 Plug (7-Pin) to Bare Drop Cable through the grommet of the CAN1 Port, and insert the LP16 Plug to one of the CAN1 Communication Ports.

i If you fail to locate the drop taps, please contact the RV manufacturer for help.

i Different drop taps are used on the RV-C bus by different RV manufacturers. This user manual takes the 4-socket drop tap as an example.

STEP-1 Install Cables on the RV-C bus

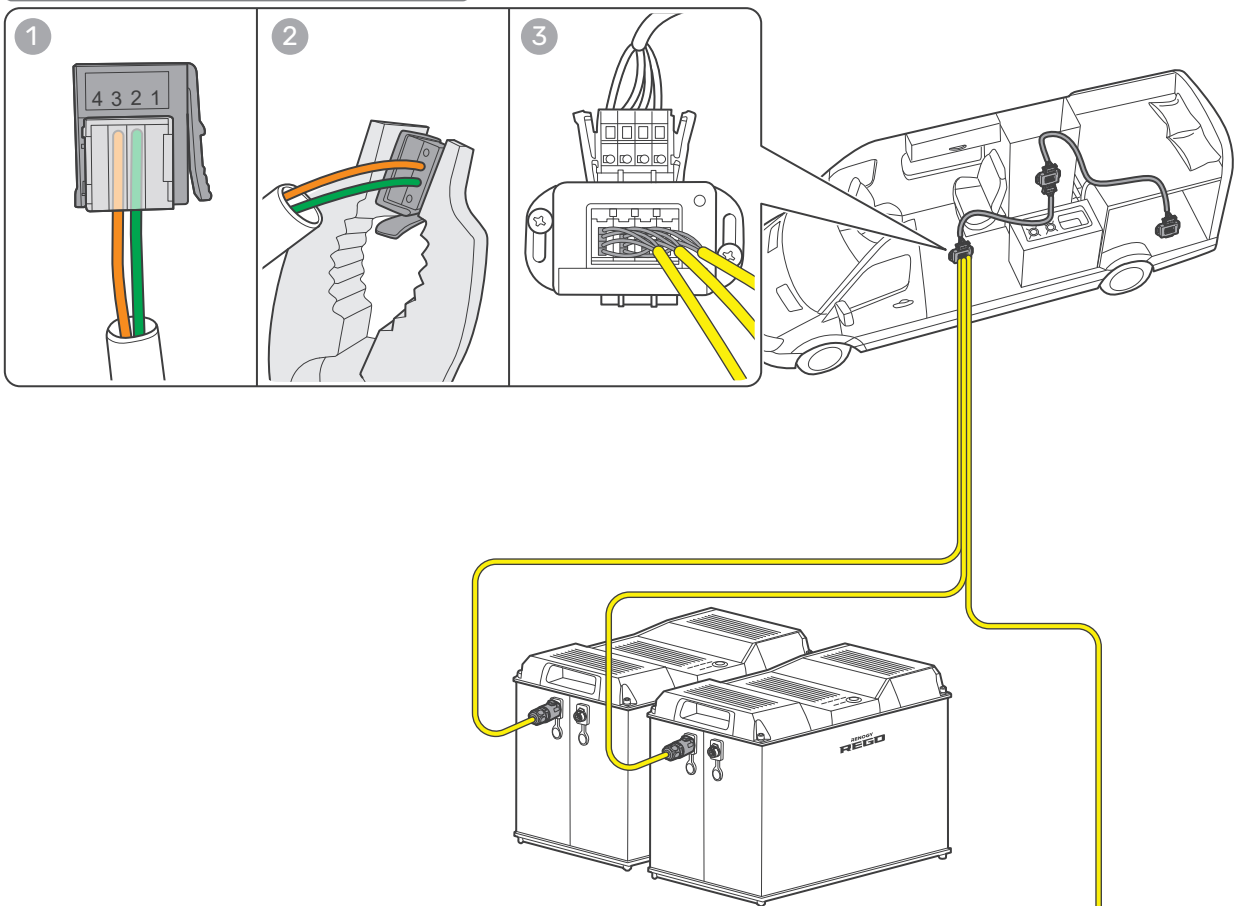

STEP-2 Install Cables on the Inverter Charger

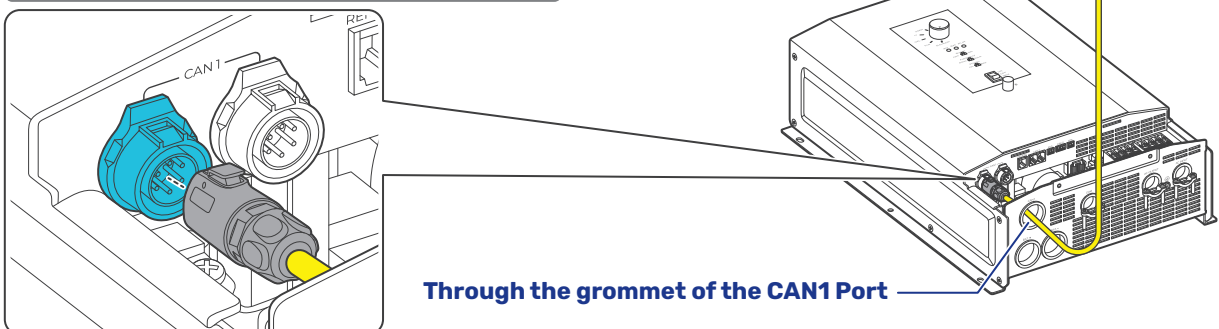

Daisy Chain Network

The daisy chain network applies to RVs that are not integrated with RV-C buses.

Recommended Accessories

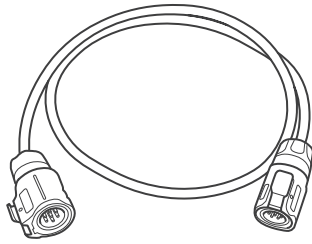

LP16 Plug (7-Pin) Communication Cable(s)

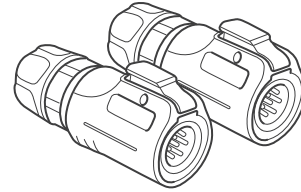

LP16 Terminator Plugs (7-Pin)

i The communication cable should be less than 19.6 feet (6 m).

Step 1: Connect REGO devices in series through either of the CAN Communication Ports with the Communication Cable(s) (sold separately).

Step 2: Plug the Terminator Plugs (sold separately) into the free CAN Communication Ports on the first and last REGO devices.

STEP-1 Install Cables on REGO devices

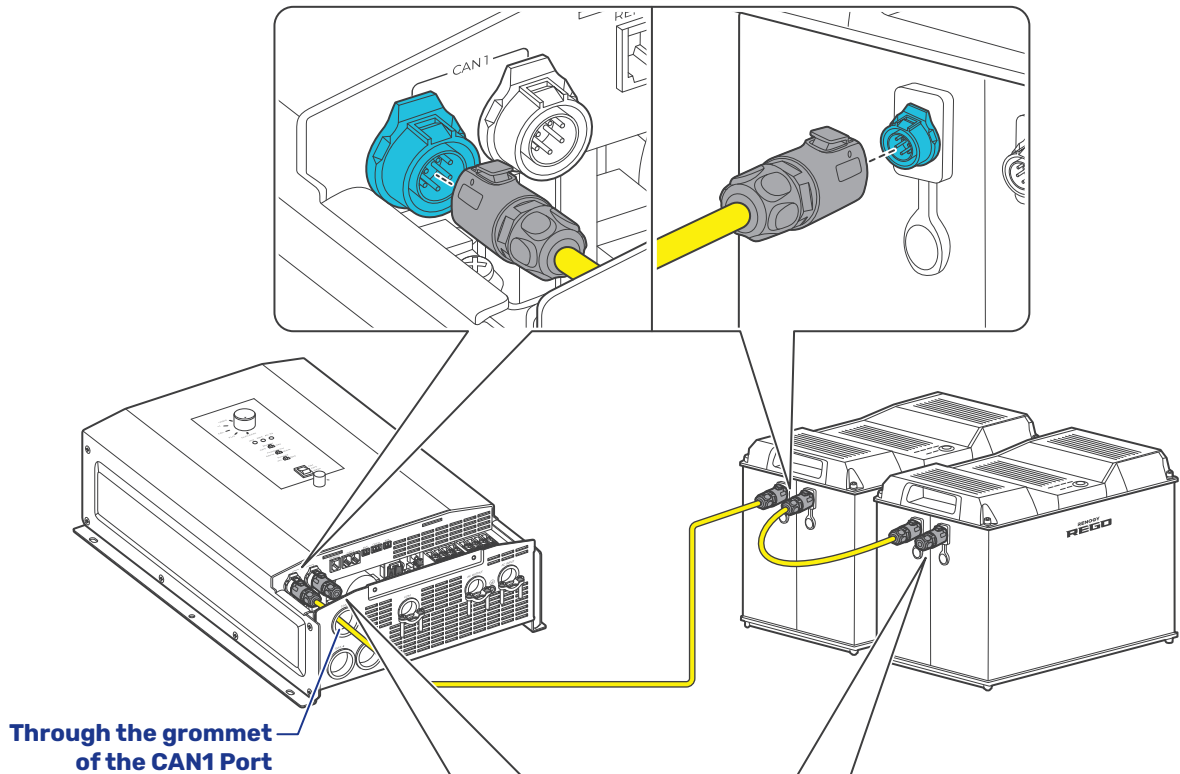

STEP-2 Install Plugs on REGO devices

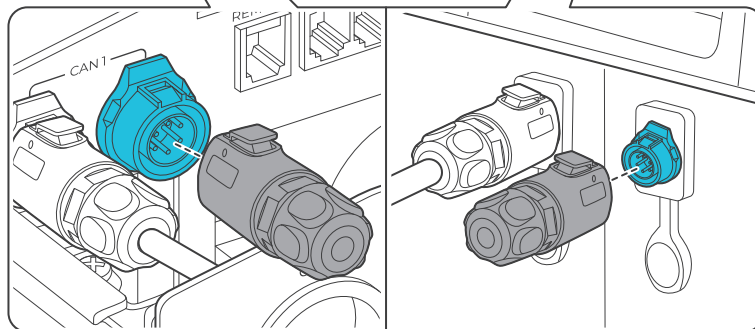

4.12. Inspection

Check and confirm all wires are firmly fastened to the inverter charger.

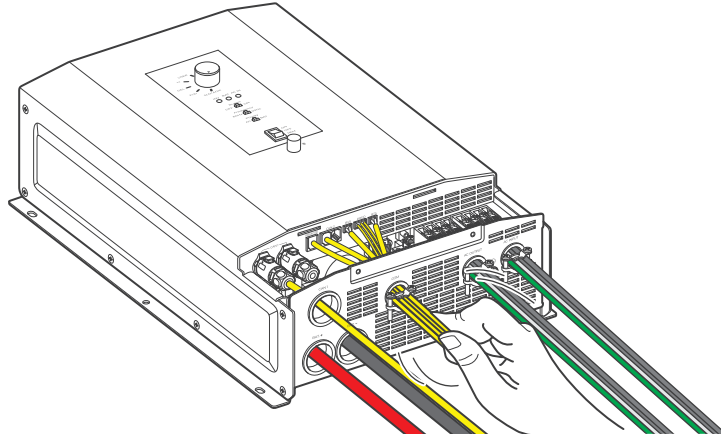

4.13. Install the Cover

Step 1: Install the cover to the inverter charger.

Step 2: Install the two cover screws clockwise either by hand or by using a Phillips screwdriver.

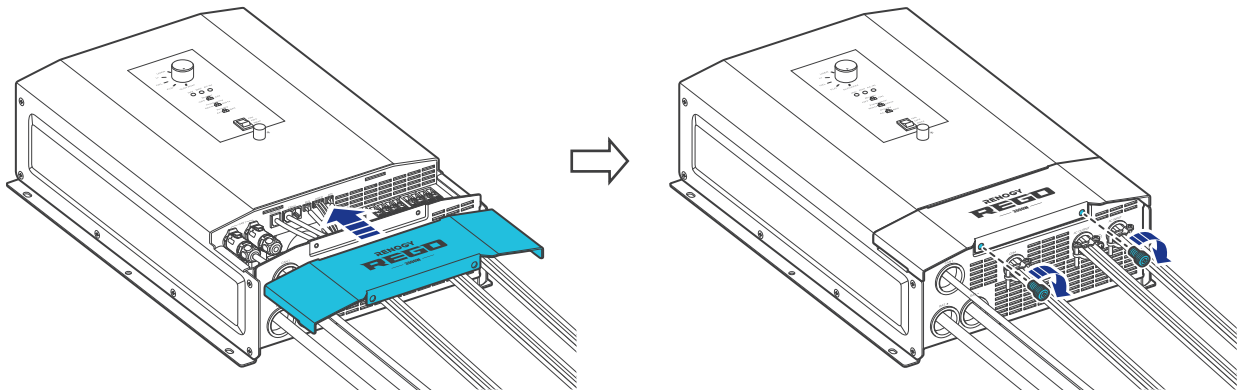

5. Configuration

5.1. N-G Bonding Relay

The inverter charger is equipped with a Neutral to Ground (N-G) bonding relay that ensures that either the neutral in or out contact of the RV is always grounded.

This helps prevent electrical shock caused by contact between the neutral contacts of the RV and external AC power sources.

By default, the Neutral to Ground bonding relay is enabled when the inverter is shipped from the factory.

When there is AC input current, the N-G bonding relay automatically connects to the grid ground contact.

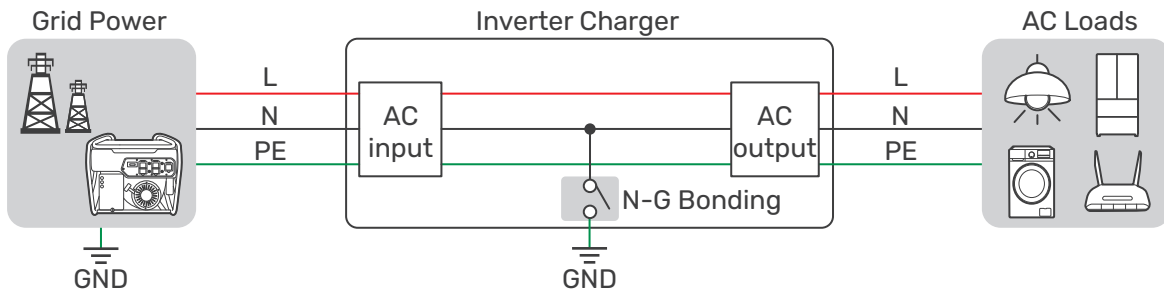

When there is no AC input current, the N-G bonding relay automatically connects to the ground contact of the inverter charger. In this case, the inverter charger supplies loads with the connected battery.

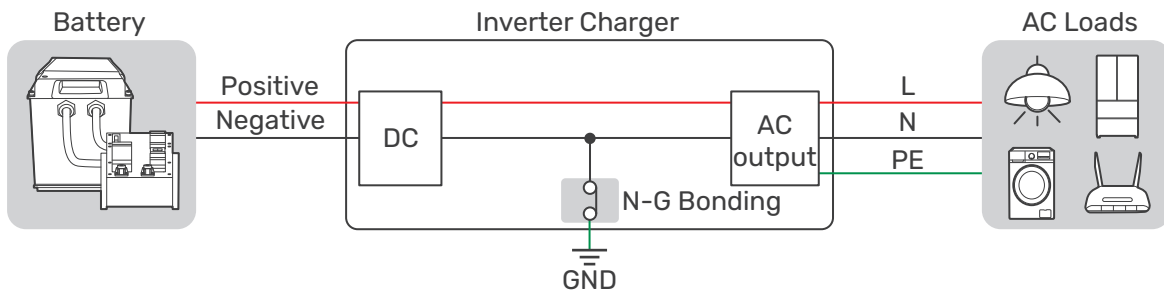

i In scenarios where the N-G bonding relay is disabled, the N-G bonding relay connects to the ground contact of the inverter charger only.

To disable the relay function, remove the N-G bonding relay screw.

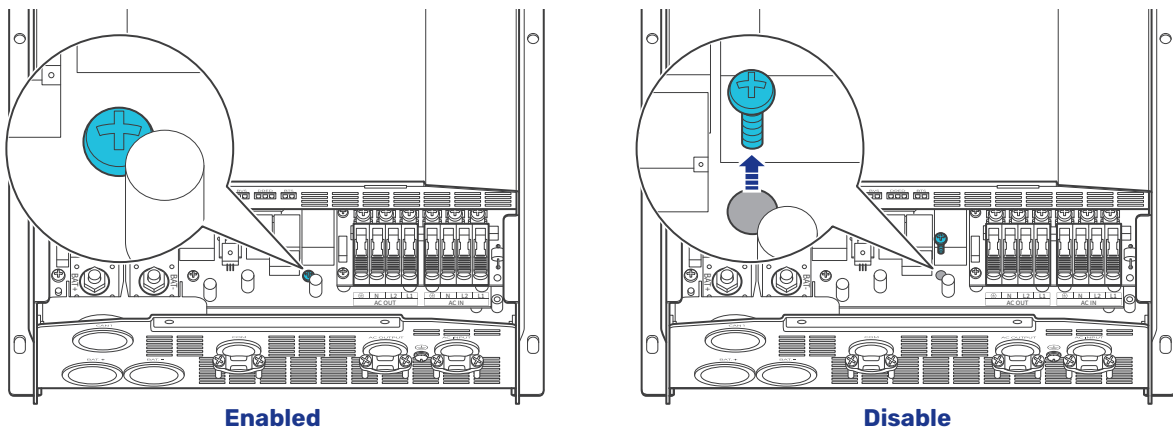

i Enabling the N-G bonding relay may lead to failure of the GFCI connected to the AC loads. In such case, remove the ground cable between the GFCI and the inverter charger.

! In scenarios when N-G bonding relay is disabled, the inverter charger must be grounded.

! Risk of electric shock! Ensure the inverter charger is powered off and all connected supplies are off when enabling or disabling the N-G bonding relay.

5.2. Configuration Panel

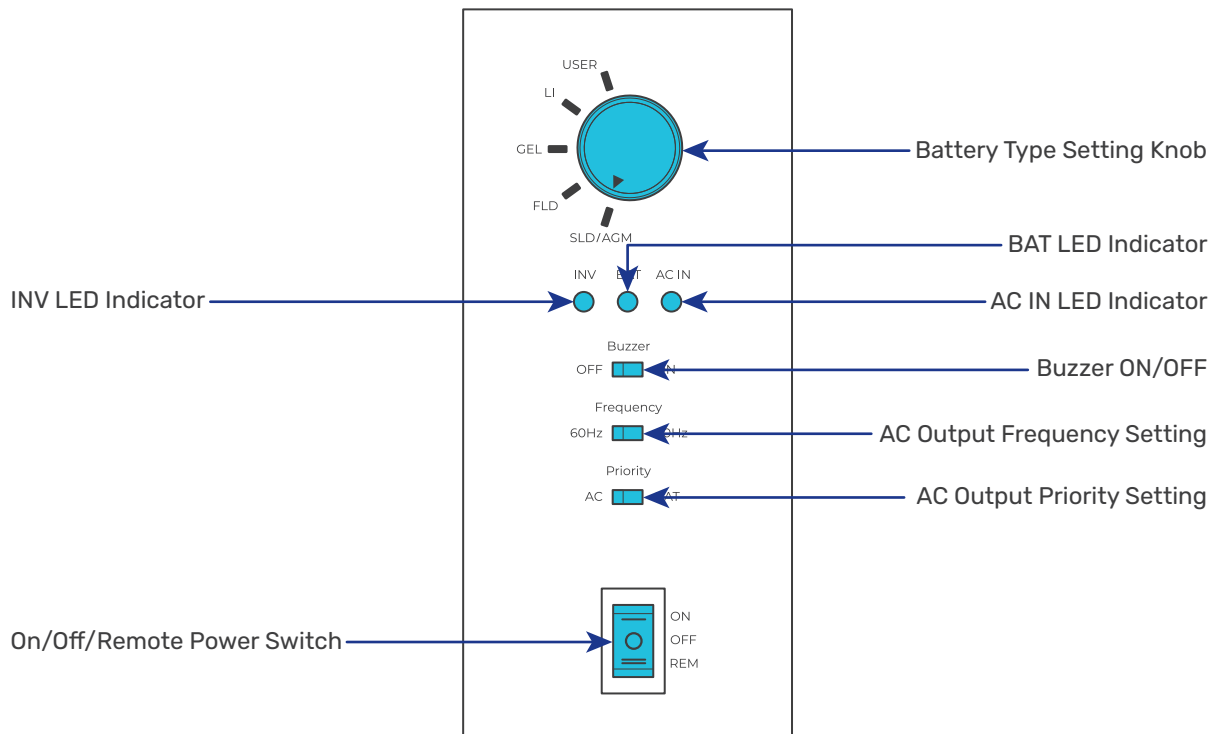

i The inverter charger generates heat when working. To prevent burns, touch the configuration panel only when the inverter charger is working.

5.3. Set a Battery Type

Upon installing the inverter charger, set a correct battery type by using the Battery Type Setting Knob.

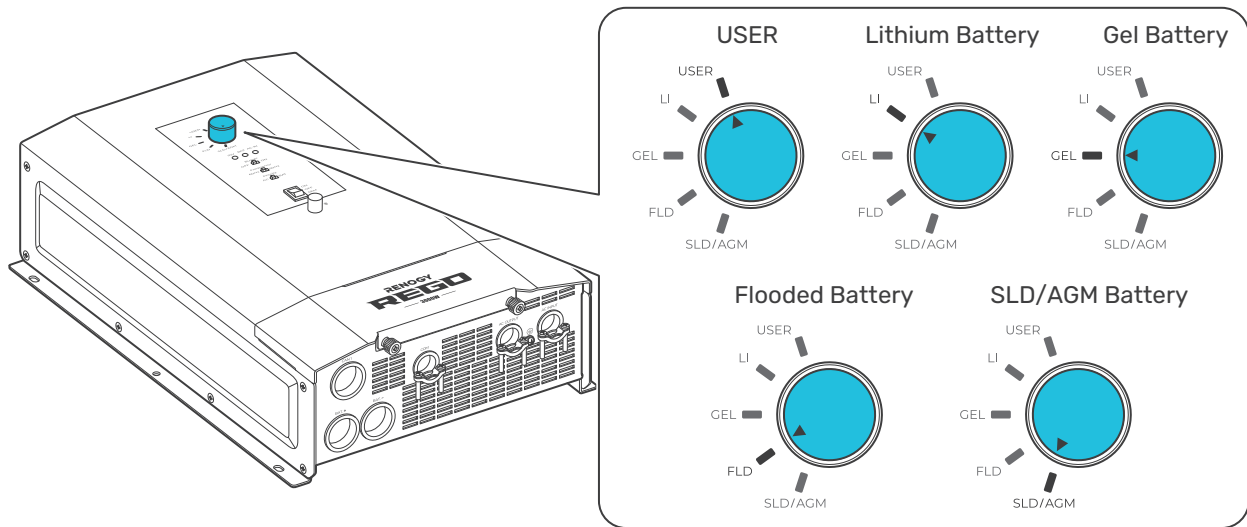

⚠ It is essential to ensure that the battery type is configured correctly to avoid any potential damage to the inverter charger because any damage to the inverter charger resulting from an incorrect battery type setting voids the warranty.

i After entering the USER mode, you need to use the DC Home app to program the battery parameters. Refer to the ["5.4 USER Mode"](#) for details.

5.4. USER Mode

Setting the battery type to USER allows you to customize your battery parameters. You can modify the parameters in the DC Home app.

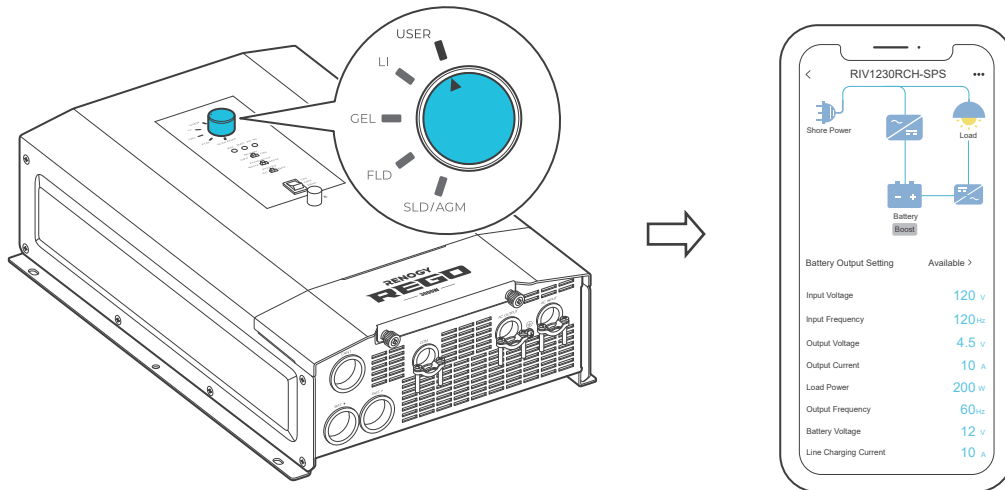

i Setting the inverter charger to USER Mode is available when the inverter charger is powered on and paired with the DC Home app. For details, see “[7. Monitor the Inverter Charger](#)”.

The table below illustrates the default and recommended parameters for batteries that can be connected to the inverter charger. The parameters may vary depending on the specific battery you use. Read the user manual of the specific battery or contact the battery manufacturer for help if necessary.

- ⚠** Before modifying battery parameters, check the table below first. Incorrect parameter setting will damage the device and void the warranty.
- ⚠** Read the user manual of the battery when customizing a preset battery. Incorrect battery type selection damages the inverter charger and voids the warranty.

Battery Type Parameters	SLD/AGM	GEL	FLOODED	LI (LFP)	USER (Default)	USER (Recommended)
	Overvoltage Shutdown	15.8V	15.8V	15.8V	15.8V	15.8V
Overvoltage Limit	15.5V	15.5V	15.5V	14.8V	15.5V	9.0–16.0V
Equalization Voltage	–	–	14.8V	–	14.8V	9.0–15.5V
Boost Voltage	14.6V	14.2V	14.6V	14.4V	14.2V	9.0–15.5V
Float Voltage	13.8V	13.8V	13.8V	–	13.8V	9.0–15.5V
Boost Return Voltage	13.2V	13.2V	13.2V	13.6V	13.2V	9.0–15.5V
Low Voltage Reconnect	12.6V	12.6V	12.6V	12.8V	12.6V	9.0–16.0V
Under Voltage Warning	12.0V	12.0V	12.0V	12.0V	12.0V	9.0–15.5V
Low Voltage Shutdown	11.1V	11.1V	11.1V	11.5V	11.1V	9.0–15.5V

Battery Type Parameters	SLD/AGM	GEL	FLOODED	LI (LFP)	USER (Default)	USER (Recommended)
	Boost Duration	120 min*	120 min*	120 min*	–	120 min*
Equalization Duration	–	–	120 min	–	120 min	0–600 min
Equalization Interval	0 day**	0 day**	30 days	–	30 days	0–255 days

- *For SLD/AGM, GEL, and Flooded batteries, the inverter charger automatically switches to float charging when the charging current drops below the tail current of the battery for 30 seconds.
- **No equalized charging.
- Parameters in grey cannot be configured manually.
- When the battery voltage reaches the Low Voltage Shutdown value, the BAT LED is solid yellow or red. Disconnect all loads, and charge the battery immediately.

Before modifying battery parameters in USER mode, check the table below and consult the battery manufacturer to check whether modification is allowed. Incorrect parameter setting will damage the device and void the warranty.

i In USER mode, when the Equalization Voltage matches the Boost Voltage and Float Voltage, the activation mechanism for the lithium battery is initiated.

Overvoltage Shutdown	The default protection voltage is 15.8V. Improper setting may affect the safety of the battery. Please consult the battery manufacturer and check if this voltage value needs to be reset.
Equalization Voltage	<ol style="list-style-type: none"> 1. For lead-acid batteries, please consult your battery manufacturer to obtain the voltage value and then complete the settings according to the feedback. 2. If equalization charging is not required, set the voltage to boost voltage.
Boost Voltage	This value affects whether the battery can be fully charged. Please consult the battery manufacturer and set the value properly.
Float Voltage	This value affects whether the battery can be fully charged. Please consult the battery manufacturer and set the value properly.
Under Voltage Warning	This voltage value affects the life of the battery. Consult the battery manufacturer and check if this voltage value needs to be set.
Low Voltage Shutdown	
Boost Duration	Please consult the battery manufacturer if it is necessary to set this parameter value.
Equalization Duration	
Equalization Interval	

5.5. Enable/Disable the Buzzer

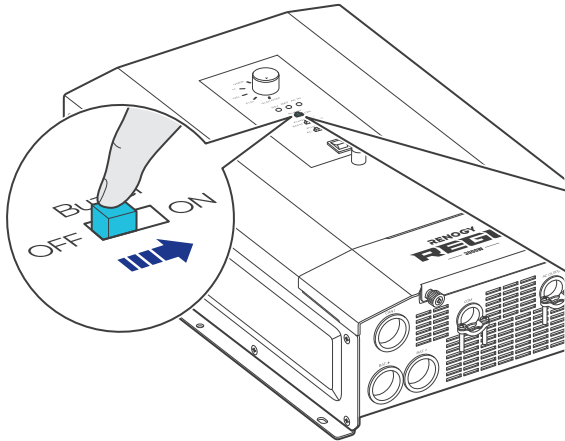

Default: OFF.

Buzzer
 OFF ON

The buzzer beeps different patterns specific to system status:

- Intermittent beeping (0.5s): Warning
- Continuous beeping: Error

Buzzer
 OFF ON

5.6. Set an AC Output Frequency

Configure the AC output frequency of the inverter charger in accordance with the frequency of the connected AC loads.



The AC output frequency should be consistent with the input source frequency.

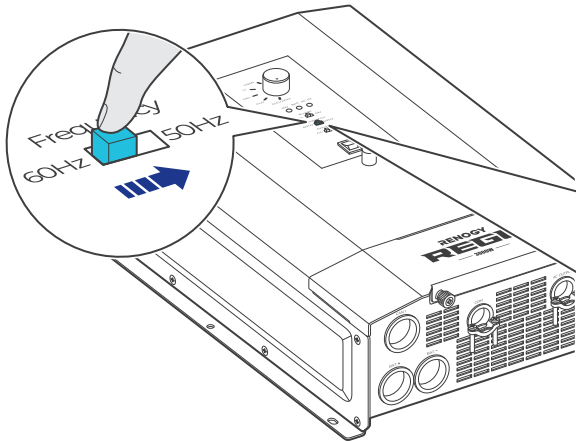

Default: 60 Hz

Frequency
 60Hz 50Hz

Option 2: 50 Hz

Frequency
 60Hz 50Hz

5.7. Set an AC Output Priority

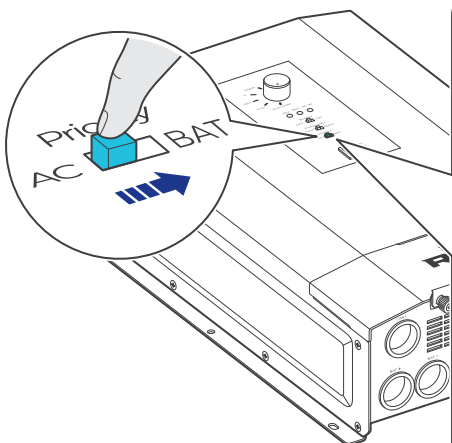

Default: AC First. In this mode, the connected loads are first supplied by the grid and then by the battery when the grid power is unavailable.

Priority
 AC BAT

Option 2: Battery First. In this mode, the connected loads are first supplied by the battery.

When the battery voltage drops below low voltage shutdown ($\pm 0.3V$), the grid charges the battery and supplies the connected loads.

The loads are again supplied by the battery when the battery charging completes.

Priority
 AC BAT



How to check whether a battery charging process completes?

- For non-lithium batteries: The battery charging is considered complete when the battery stays in the float charging stage for 2 hours.
- For lithium batteries: The battery charging is considered complete when the battery stays in the constant voltage charging stage with a charging current less than the battery tail current for 2 hours.

6. Power On/Off and LED Indicators

6.1. Power On/Off

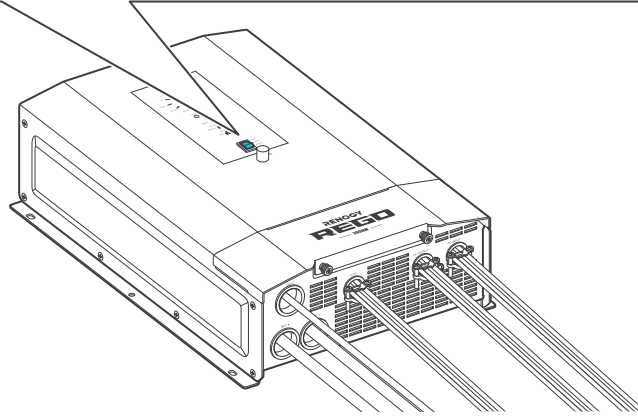

Method 1: Through On/Off/Remote Power Switch

	OFF: The inverter charger is off. The inverter charger uses grid power to directly power AC loads or appliances without drawing power from the batteries. The grid charges the connected battery at the same time.
	ON: The inverter charger is on. The inverter charger prioritizes charging the batteries or supplying power to the loads from the grid based on the AC Output Priority. In this mode, the grid and batteries can work together to power loads up to a combined load of 6000W.
	REM: Turn on or off the inverter charger via the Wired Remote Control.



Method 2: Through Wired Remote Control

Push the On/Off/Remote Power Switch to the REM position. Press the RMS-P button to power on or off the inverter charger.

 ON	The inverter charger is off. The inverter charger uses grid power to directly power AC loads or appliances without drawing power from the batteries. The grid charges the connected battery at the same time.
 ON	The inverter charger is on. The inverter charger prioritizes charging the batteries or supplying power to the loads from the grid based on the AC Output Priority. In this mode, the grid and batteries can work together to power loads up to a combined load of 6000W.

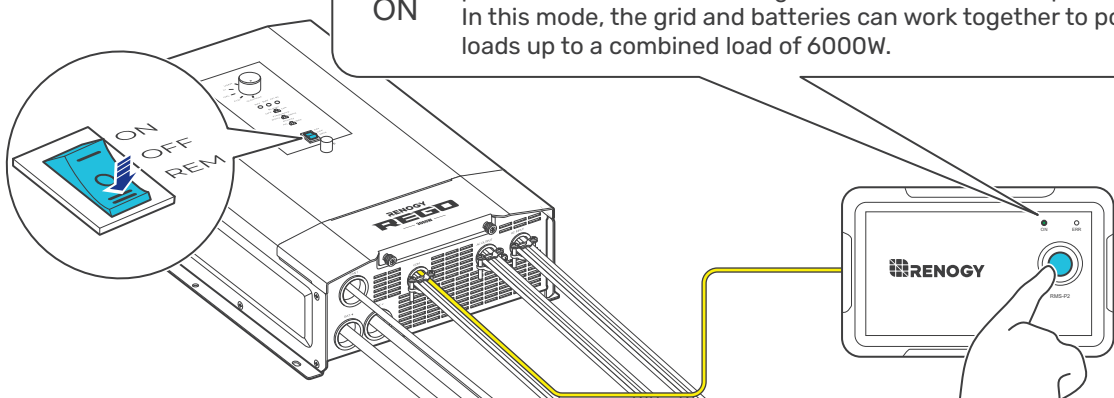

6.2. LED Indicators

Indicator of the Inverter Charger

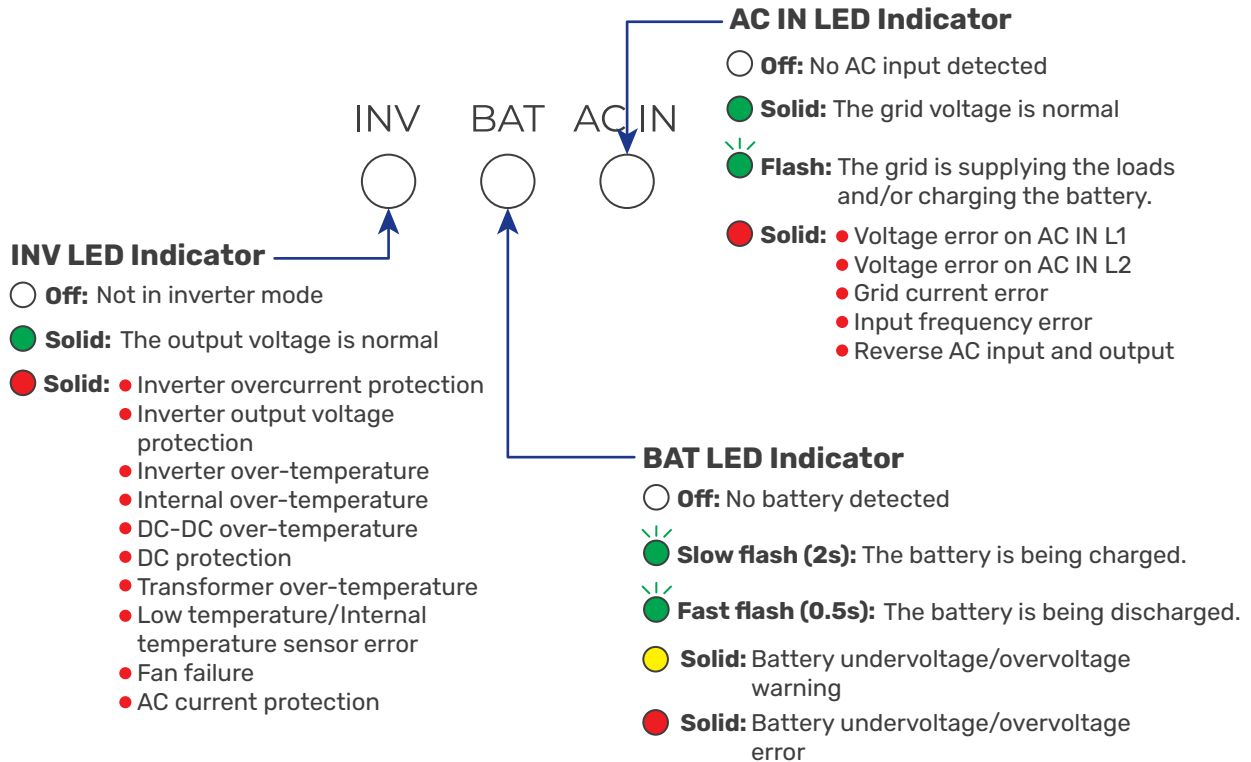

Indicator of the Wired Remote Control



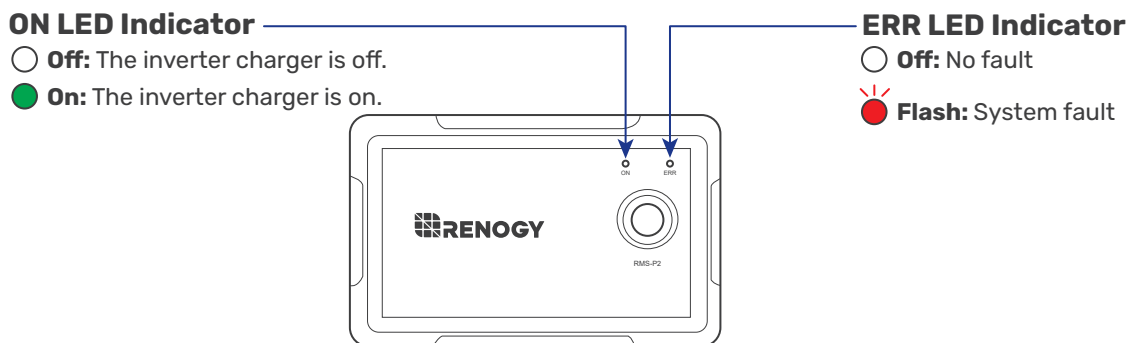

You can also check the operating status of the inverter charger on the Wired Remote Control.



i A solid yellow or red LED indicates that the inverter charger is faulty. Please login to the DC Home app for troubleshooting details.

7. Monitor the Inverter Charger

Depending on the specific application, the inverter charger can establish either short-range or long-range communication connections with monitoring devices. These monitoring devices facilitate real-time monitoring, programming, and complete system management, offering comprehensive control and enhanced flexibility.

-  Make sure the Bluetooth of your phone is turned on.
-  The version of the DC Home app might have been updated. Illustrations in the user manual are for reference only. Follow the instructions based on the current app version.
-  Make sure that the inverter charger is properly installed and powered on before it is paired with the DC Home app.
-  To ensure optimal system performance, keep the phone within 10 feet (3 m) of the inverter charger.

Download the DC Home app. Login to the app with your account.

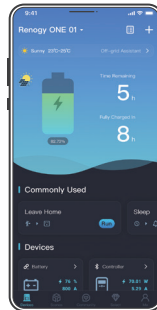

DC Home App



7.1. Short-Range Monitoring via DC Home App

If only short-range monitoring is required, connect the inverter charger to the DC Home app directly through the Bluetooth of your phone.

Step 1: Open the DC Home app. Tap + to search for new devices.

Step 2: Tap **Confirm** to add the newly found device to the device list.

Step 3: Tap the inverter charger icon to enter the device information interface.



7.2. Wireless Long-Range Monitoring

If long-range communication and programming are required, connect the inverter charger to Renogy ONE through Bluetooth, and the Renogy ONE to the DC Home app through Wi-Fi.

Recommended Components

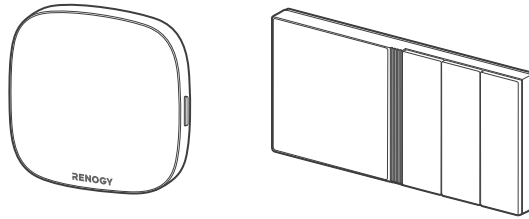

*RENOGY ONE Core or Renogy ONE M1

- i** Components marked with "*" are available on [renogy.com](https://www.renogy.com).
- i** Make sure that the Renogy ONE is powered on before the connection.
- i** For instructions on Renogy ONE, see [Renogy ONE Core User Manual](#) and [Renogy ONE M1 User Manual](#).
- i** Make sure the inverter charger does not communicate with any other device.

Step 1: Connect the inverter charger to the Renogy ONE through the Bluetooth of your phone.

Step 2: Pair the Renogy ONE with the DC Home app through Wi-Fi.



7.3. Wired Long-Range Monitoring (Backbone Network)

If long-range communication and programming are required, connect the inverter charger to Renogy ONE through wires, and the Renogy ONE to the DC Home app through Wi-Fi.

Recommended Components & Accessories

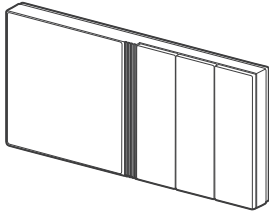

*Renogy ONE M1

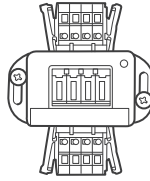

Common Drop Tap

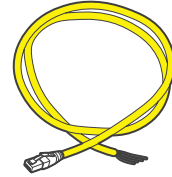

RJ45 Plug to Bare Drop Cable

- i** Components marked with "*" are available on [renogy.com](https://www.renogy.com).
- i** Make sure that the Renogy ONE is powered on before the connection.
- i** For instructions on Renogy ONE M1, see [Renogy ONE M1 User Manual](#).
- i** Make sure the inverter charger does not communicate with any other device.
- i** Select the appropriate communication cable (sold separately) according to the distance between devices. The communication cable should be less than 19.6 feet (6 m).
- i** Different terminal block plugs are used on different Common Drop Taps and follow different pinouts. If you are unsure about the pinout of the terminal block plug, contact the RV manufacturer.

Step 1: Replace the terminated drop tap at either end of the RV-C bus with the Common Drop Tap (not included). Secure the bare wires of the Drop Cable (not included) onto the terminal block plug of the Common Drop Tap following the terminal block plug pinout. Plug the Drop Cable to the RJ45 port of Renogy ONE.

Step 2: Monitor and program the complete system on Renogy ONE or the DC Home app.

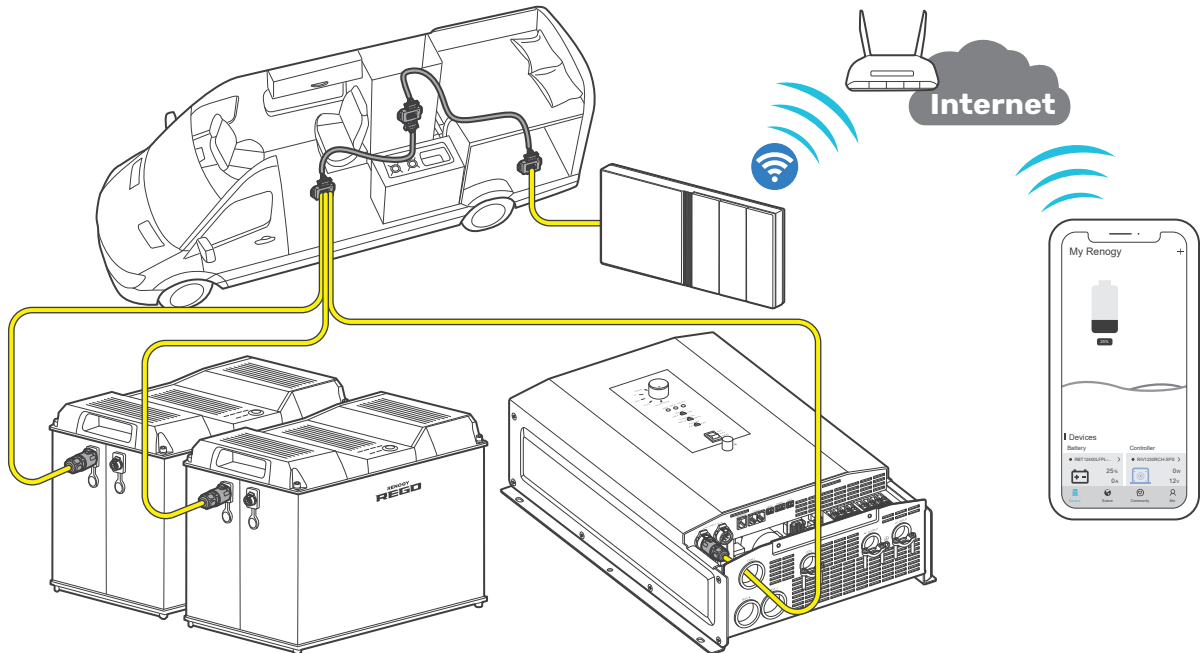

7.4. Wired Long-Range Monitoring (Daisy Chain Network)

If long-range communication and programming are required, connect the inverter charger to Renogy ONE through wires, and the Renogy ONE to the DC Home app through Wi-Fi.

Recommended Components & Accessories

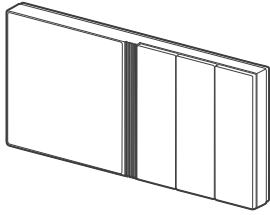

*Renogy ONE M1

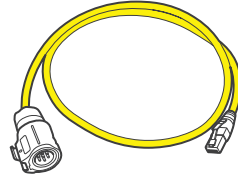

LP16 Plug (7-Pin) to RJ45 Communication Adapter Cable

- i** Components marked with "*" are available on [renogy.com](https://www.renogy.com).
- i** Make sure that the Renogy ONE is powered on before the connection.
- i** For instructions on Renogy ONE M1, see [Renogy ONE M1 User Manual](#).
- i** Make sure the inverter charger does not communicate with any other device.
- i** Select the appropriate communication cable (sold separately) according to the distance between devices. The communication cable should be less than 19.6 feet (6 m).

Step 1: Remove the Terminator Plug from the REGO device at either end of the daisy chain.

Step 2: Connect the Renogy ONE to the free CAN Communication Port on the REGO device with the Communication Adapter Cable (sold separately).

Step 3: Pair Renogy ONE with the DC Home app. Monitor and program the complete system on the Renogy ONE or the DC Home app.

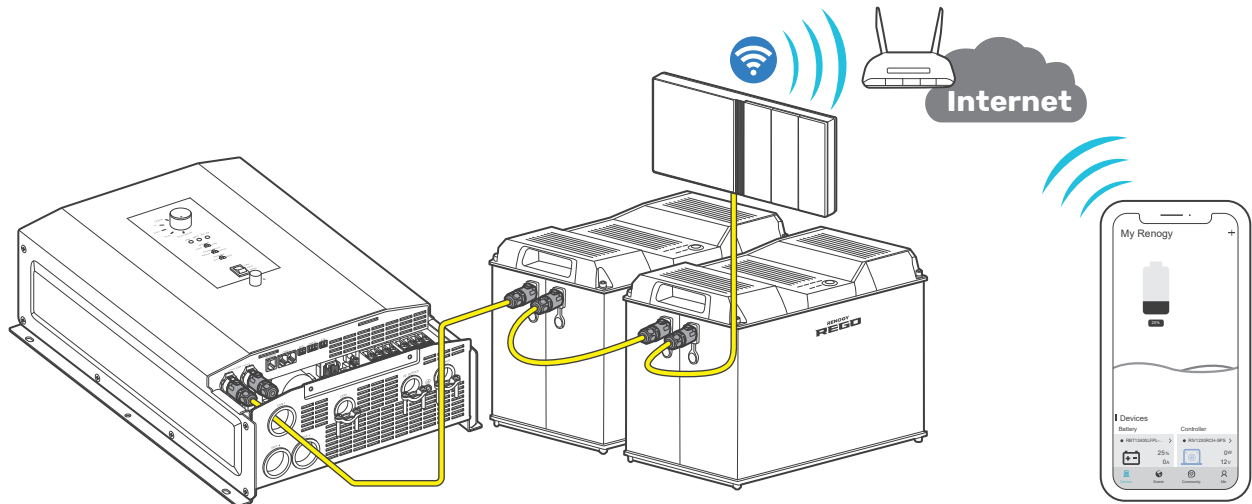

8. Working Logic

REGO 12V 3000W HF Inverter Charger combines an inverter charger with an automatic transfer switch into one complete system.

Featuring a three-stage battery charging mode when connected to the AC grid input, the inverter charger is capable of producing cleaner, smoother, and more reliable electricity to address your diverse needs.

8.1. Power Supply Logic

■ Supply by Battery First

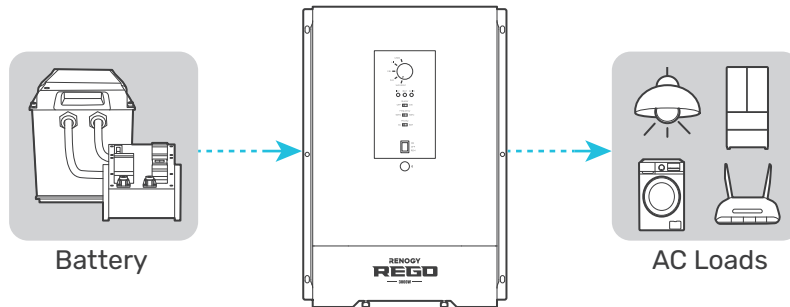

The inverter charger works in Battery First mode when all of the following conditions are met:

- The AC Output Priority button is toggled to BAT.
- The battery voltage is no lower than the Low Voltage Shutdown value.
- The battery current is sufficient to power the connected loads.

i When none of the designated working conditions are met, the inverter charger seamlessly transitions to AC First mode. In instances where grid power is unavailable, the inverter charger ceases its operation.

i If the battery fails to supply all loads, the grid seamlessly joins in to provide the necessary power.

■ Supply by AC First

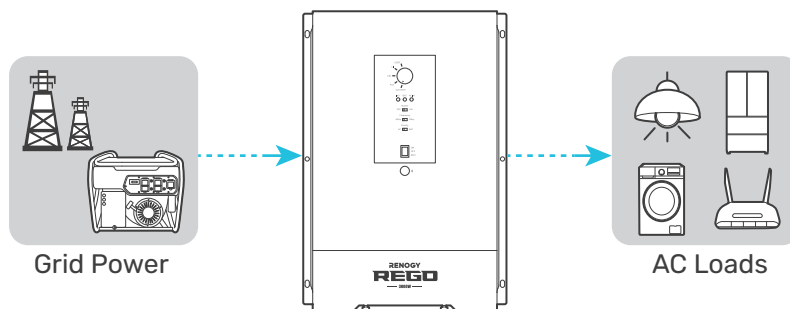

The inverter charger works in AC First mode when all of the following conditions are met:

- The AC Output Priority button is toggled to AC.
- Grid power is available.
- The grid power is sufficient to supply all loads.

i When none of the designated working conditions are met, the inverter charger seamlessly transitions to Battery First mode. In instances where the battery voltage is lower than the Low Voltage Shutdown value, the inverter charger ceases its operation.

i If the grid fails to supply all loads, the battery seamlessly joins in to provide the necessary power.

Supply by Both Battery and AC

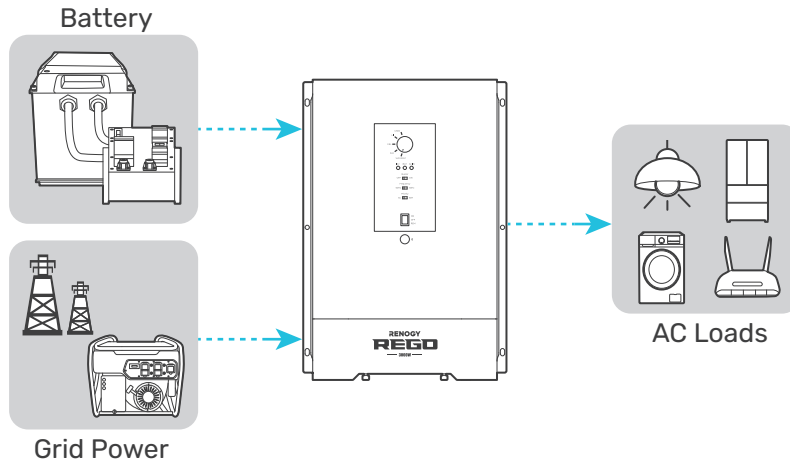

The inverter charger uses both battery and grid as the supply when all of the following conditions are met:

- Neither the battery nor the grid can independently supply all loads.
- The battery voltage is no lower than the Low Voltage Shutdown value.

i When none of the designated working conditions are met, the inverter charger seamlessly transitions to AC First mode. Powering off some loads to ensure the grid can supply the rest loads and the inverter charger charges the battery.

8.2. Charging Logic

In AC First mode where the grid power is the only supply source, the inverter charger automatically recognizes the battery voltage and charges the battery.

By default, the inverter charger charges the battery at 150A. You can customize the charging current to a value between 5A and 150A on the DC Home app. For the recommended charging current, refer to the user manual of the specific battery.

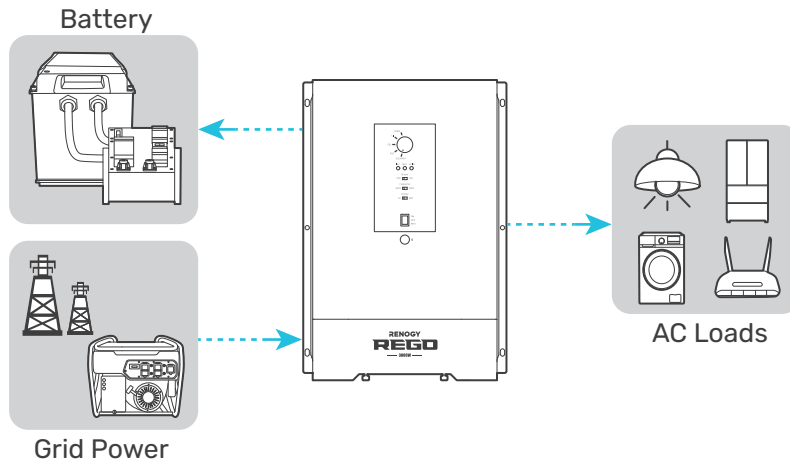

Battery Voltage	Charging Status
Drops to the Overvoltage Limit value: <ul style="list-style-type: none"> ● For lithium batteries: 14.8V (default) ● For non-lithium batteries: 15.5V (default) 	Start charging
Rises to Overvoltage Shutdown value: 15.8V (default)	Stop charging

8.3. Battery Charging Stages

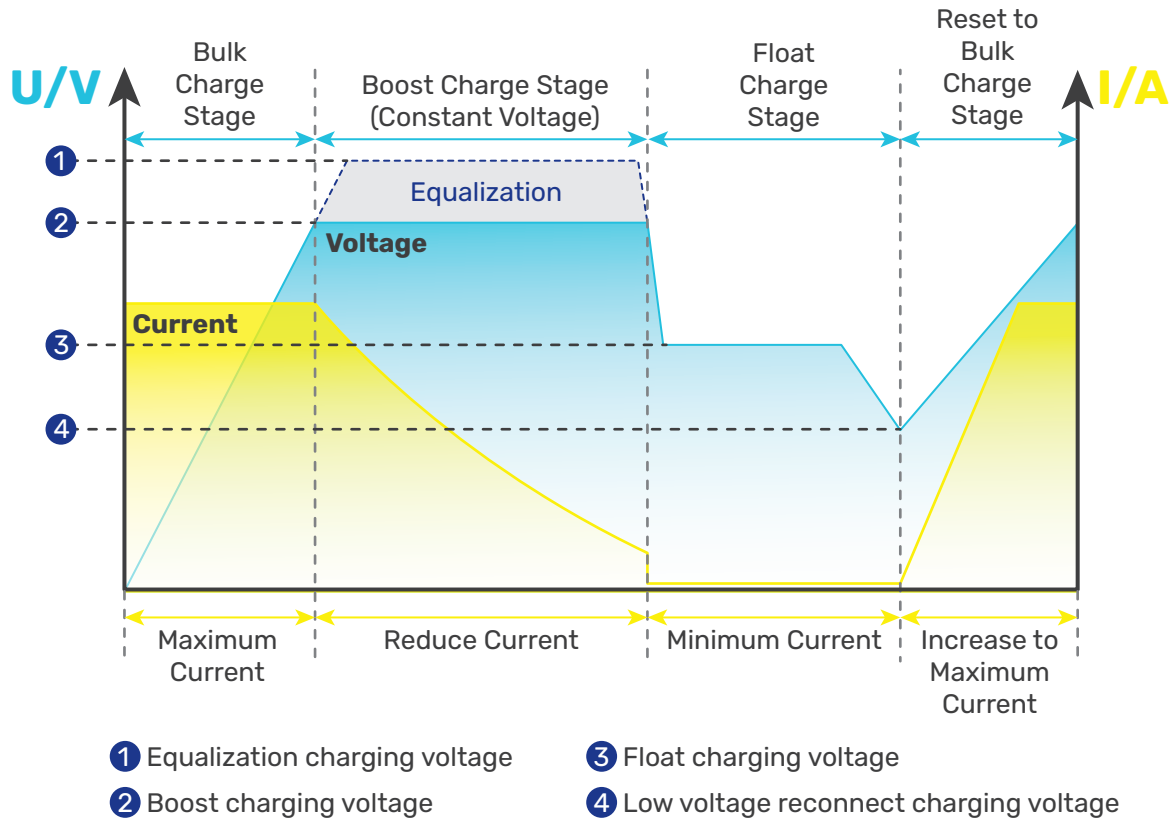

i Adjust the time depending on the specific battery bank size.

■ Bulk Charge Stage

The inverter charger will supply constant current until the battery voltage reaches the boost voltage.

■ Boost Charge Stage

The inverter charger will supply constant voltage and reduce the current slowly through this stage. By default, the Boost Duration is set to 2 hours. You can customize it on the DC Home app. After this time the charger will enter the float stage.

i For details on Boost Duration, see “[5.4. USER Mode](#)” in this user manual.

i Boost Duration is not required for lithium batteries.

i The stage is determined by internal software in the inverter charger.

■ Float Charge Stage

During this stage the inverter charger will supply a constant voltage which is determined by the battery selected and will keep current at a minimum level. This stage acts as a trickle charger.

i The float charge stage is not applicable to lithium batteries.

■ Equalization

This stage is only available for batteries with equalization, such as flooded. During this stage the batteries are charged at a higher voltage than normal and for most batteries this could cause damage. Refer to the user manual of the battery or contact the battery manufacturer to see if this stage is needed.

8.4. Heat Dissipation Logic

The inverter charger uses fans for heat dissipation. The working logic of the fans is as follows:

Inverter Charger	Inverter Charger Power	Fan
Inlet air temperature $\geq 86^{\circ}\text{F}$ (30°C)	–	ON
Internal temperature $\geq 104^{\circ}\text{F}$ (40°C)	–	ON
–	$\geq 200\text{W}$	ON

 The fans start working when any of the above condition is met.

 The inverter charger fans start working when the output reaches 200W or higher, with the fan speed increasing as the output power rises. The fans operate at full speed when the output power reaches 2700W.

8.5. Activation Logic for Lithium Battery

The inverter charger can activate connected lithium batteries. Lithium batteries may enter sleep mode when the in-built protection is triggered. In such case, the inverter charger provides a small current to reactivate the sleeping lithium battery. The lithium battery can be charged normally after successful activation.

■ Operation Conditions

1. Set the battery type of the inverter charger to LI or USER. For details, see “[5.3. Set a Battery Type](#)”.
2. Ensure the inverter charger is connected to the grid and the grid power is accessible.

■ Operation Logic

1. In lithium battery mode, the inverter charger automatically enables the activation function and provides a constant voltage of over 14.0V to 14.4V to activate the lithium battery.
2. After activation for 1 minute, the inverter charger temporarily stops activation and detects the battery voltage again. If the battery voltage is no less than 9V, the inverter charger will automatically turn off the activation mode. Otherwise, it will continue to activate the lithium battery.

 By default, the lithium activation function is enabled in the inverter charger. You can disable it in the DC Home app.

8.6. Heating Module Activation Logic for Lithium Battery

The inverter charger is equipped with a heating module that enables the connected lithium battery to function normally even at temperatures as low as 32°F (0°C) by providing heat to the battery. This feature ensures that the inverter charger can operate smoothly even in extremely cold conditions down to -4°F (-20°C).

9. Troubleshooting

A solid yellow or red LED indicates that the inverter charger is faulty. Please login to the DC Home app for troubleshooting details.

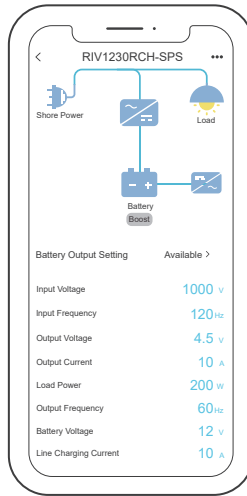

Problem	Possible Causes	Solution
No battery is detected.	<ol style="list-style-type: none"> The cables between the battery and the inverter charger are loose. Abnormal battery voltage 	<ol style="list-style-type: none"> Check the cable wiring between the battery and the inverter charger, and ensure the cables are correctly and firmly installed. Measure the battery voltage with a multimeter. A normal battery voltage should range from 11V to 15.8V. The inverter charger may fail to detect the battery when the battery voltage is lower than 11V. In such case, charge the battery, and reconnect it to the inverter charger.
The DC Home app fails to discover the inverter charger.	<ol style="list-style-type: none"> Your phone's Bluetooth is off. The inverter charger is off. The inverter charger is far away from the phone or tablet where the DC Home app runs. 	<ol style="list-style-type: none"> Turn on Bluetooth on your phone or tablet. Turn on the inverter charger. Keep the phone or tablet within 10 feet (3 m) of the inverter charger.



For technical support, contact our technical service through renogy.com/contact-us.

10. Dimensions & Specifications

10.1. Dimensions

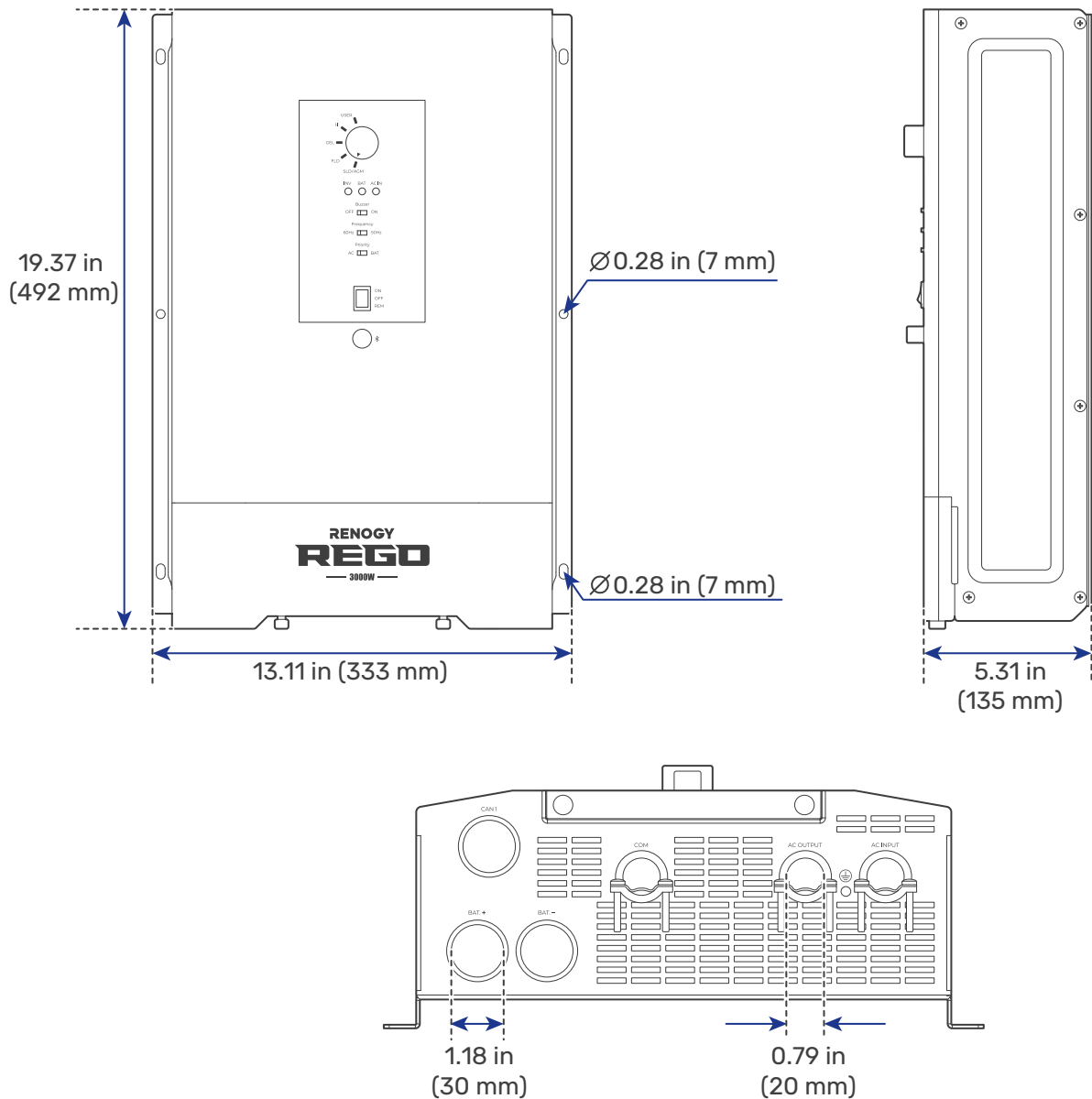

i Dimension tolerance: ± 0.2 in (0.5 mm)

10.2. Technical Specifications

Inverter Specifications	
Rated Output Power	3000W @113°F (45°C)
Surge Power (100 ms)	9000VA
Surge Power (5 seconds)	4500VA
Surge Power (10 seconds)	3600W
Nominal Output Voltage RMS	120V AC ($\pm 3\%$)
Output Frequency	50Hz (± 0.3 Hz) / 60Hz (± 0.3 Hz)
Output Wave Form	Pure Sine Wave

Nominal Input Voltage	12V DC
Input Voltage Range	9V to 17V DC ($\pm 0.3V$) (Full load 11V to 15.8V DC)
Short Circuit Protection	Software Protection
Total Harmonics Distortion (THD)	< 3% (Resistance load)
Nominal Efficiency	> 91% peak
No load power Consumption	< 20W (Normal)
Short Circuit Protection	Circuit Breaker
Charger Specifications	
Nominal Input Voltage	Split phase: 180V to 280V AC Single phase: 90V to 140V AC
Input Frequency Range	50Hz ($\pm 5Hz$) / 60Hz ($\pm 5Hz$)
Optimal Efficiency	> 90%
Output Current	150A @25°C, 5A to 150A adjustable, 5A intervals, default 150A
Transfer Switch Specifications	
Transfer Time	10 ms
Transfer Relay Rating	50A Maximum Bypass @120V AC
General Specifications	
Battery Types	SLD, AGM, GEL, FLD, LI and USER
Operating Temperature Range	Full load: -4°F to 113°F / -20°C to 45°C Down load: 113°F to 140°F / 45°C to 60°C
Storage Temperature	-40°F to 158°F / -40°C to 70°C
Humidity	0% to 95%, RH
Noise	< 54dB
Dimensions	19.37 x 13.11 x 5.31 in / 492 x 333 x 135 mm
Weight	22.7 lbs / 10.3 Kg
Wired Remote Control	
Dimensions	2.8 x 4.3 x 1.3 in / 70 x 110 x 31.8 mm
Wire length	Approx 16.4ft
Certifications	
EMC certification	FCC Part 15 Class B
Safety	UL-485 and CSA-C22.2 No 107.1
Warranty	
5 Years	

11. Maintenance

11.1. Inspection

For optimum performance, it is recommended to perform these tasks regularly.

- Ensure the inverter charger is installed in a clean, dry and ventilated area.
- Ensure there is no damage or wear on the cables.
- Ensure the firmness of the connectors and check if there are any loose, damaged or burnt connections.
- Make sure the indicators are in proper condition.
- Ensure there is no corrosion, insulation damage, or discoloration marks of overheating or burning.
- If the inverter charger is dirty, use a damp cloth to clean the outside of the device to prevent dust and dirt from accumulating. Before the inverter charger is powered on, make sure it is completely dry after cleaning.
- Make sure the ventilation holes are not blocked.

 In some applications, corrosion may exist around the terminals. Corrosion can loosen springs and increase resistance, leading to premature connection failure. Apply dielectric grease to each terminal contact periodically. Dielectric grease repels moisture and protects the terminal contacts from corrosion.

 Risk of electric shock! Make sure that all power supplies are turned off before touching terminals on the inverter charger.

11.2. Cleaning

Follow the steps below to clean the inverter charger regularly.

- Disconnect all cables connected to the inverter charger.
- Wear proper protective equipment and use insulated tools during operation. Be careful when touching bare terminals of capacitors as they may retain high lethal voltages even after power is removed.
- Wipe the housing of the inverter charger and connector contacts with a dry cloth or nonmetallic brush. If it is still dirty, you can use household cleaners.
- Make sure the ventilation holes are not blocked.
- Dry the inverter charger with a clean cloth and keep the area around the inverter charger clean and dry.
- Make sure the inverter charger is completely dry before reconnecting it to the battery and AC input.

11.3. Storage

Follow the tips below to ensure that the inverter charger is stored well.

- Disconnect all cables connected to the inverter charger.
- By applying dielectric grease to each terminal, the dielectric grease repels moisture and protects the connector contacts from corrosion.
- Store the inverter charger in a well-ventilated, dry, and clean environment with the temperature between -40°F to 158°F (-40°C to 70°C).

12. Emergency Responses

In the event of any threat to health or safety, always begin with the steps below before addressing other suggestions.

- Immediately contact the fire department or other relevant emergency response team.
- Notify all people who might be affected and ensure that they can evacuate the area.

 Only perform the suggested actions below if it is safe to do so.

12.1. Fire

1. Disconnect all cables connected to the inverter charger.
2. Put out the fire with a fire extinguisher. Acceptable fire extinguishers include water, CO₂, and ABC.

 Do not use type D (flammable metal) fire extinguishers.

12.2. Flooding

1. If the inverter charger is submerged in water, stay away from the water.
2. Disconnect all cables connected to the inverter charger.

12.3. Smell

1. Ventilate the room.
2. Disconnect all cables connected to the inverter charger.
3. Ensure that nothing is in contact with the inverter charger.

12.4. Noise

1. Disconnect all cables connected to the inverter charger.
2. Make sure no foreign objects are stuck in the fan of the inverter charger or the ring terminal.

 The normal noise value of the inverter charger is less than 54dB during operation. If the noise is abnormal, contact our technical service through renogy.com/contact-us.

Renogy Support

To discuss inaccuracies or omissions in this quick guide or user manual, visit or contact us at:

 | renogy.com/support/downloads

 → contentservice@renogy.com

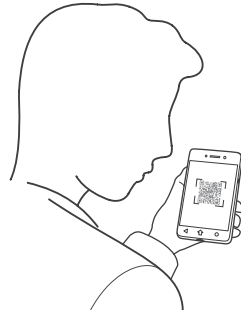

Questionnaire Investigation



To explore more possibilities of solar systems, visit Renogy Learning Center at:

 | renogy.com/learning-center

For technical questions about your product in the U.S., contact the Renogy technical support team through:

 | renogy.com/contact-us

 1(909)2877111

For technical support outside the U.S., visit the local website below:

Canada |  | ca.renogy.com

China |  | www.renogy.cn

Australia |  | au.renogy.com

Japan |  | renogy.jp

South Korea |  | kr.renogy.com

Germany |  | de.renogy.com

United Kingdom |  | uk.renogy.com

Other Europe |  | eu.renogy.com

FCC Statement

This device complies with Part 15 of the FCC Rules. Operation is subject to the following two conditions:

- (1) This device may not cause harmful interference.
- (2) This device must accept any interference received, including interference that may cause undesired operation.

Any Changes or modifications not expressly approved by the party responsible for compliance could void the user's authority to operate the equipment.

This equipment has been tested and found to comply with the limits for a Class B digital device, pursuant to Part 15 of the FCC Rules. These limits are designed to provide reasonable protection against harmful interference in a residential installation. This equipment generates, uses and can radiate radio frequency energy and, if not installed and used in accordance with the instructions, may cause harmful interference to radio communications. However, there is no guarantee that interference will not occur in a particular installation. If this equipment does cause harmful interference to radio or television reception, which can be determined by turning the equipment off and on, the user is encouraged to try to correct the interference by one or more of the following measures:

- (1) Reorient or relocate the receiving antenna.
- (2) Increase the separation between the equipment and receiver.
- (3) Connect the equipment into an outlet on a circuit different from that to which the receiver is connected.
- (4) Consult the dealer or an experienced radio / TV technician for help.

FCC Radiation Exposure Statement

This equipment complies with FCC radiation exposure limits set forth for an uncontrolled environment. This equipment should be installed and operated with minimum distance 20 cm between the radiator & your body.



Renogy Empowered

Renogy aims to empower people around the world through education and distribution of DIY-friendly renewable energy solutions.

We intend to be a driving force for sustainable living and energy independence.

In support of this effort, our range of solar products makes it possible for you to minimize your carbon footprint by reducing the need for grid power.



Live Sustainably with Renogy

Did you know? In a given month, a 1kW solar energy system will...



Save 170 pounds of coal from being burned



Save 300 pounds of CO₂ from being released into the atmosphere



Save 105 gallons of water from being consumed



Renogy Power PLUS

Renogy Power Plus allows you to stay in the loop with upcoming solar energy innovations, share your experiences with your solar energy journey, and connect with like-minded people who are changing the world in the Renogy Power Plus community.



@Renogy Solar



@renogyofficial



@Renogy

Renogy reserves the right to change the contents of this manual without notice.



Intertek
5016367

IC: 23590-RIV1230RCH

Contains TX FCC ID: 2ANPB-RIV1230RCH