

# REGO Inverter Charger

12V | 3000W

VERSION A0

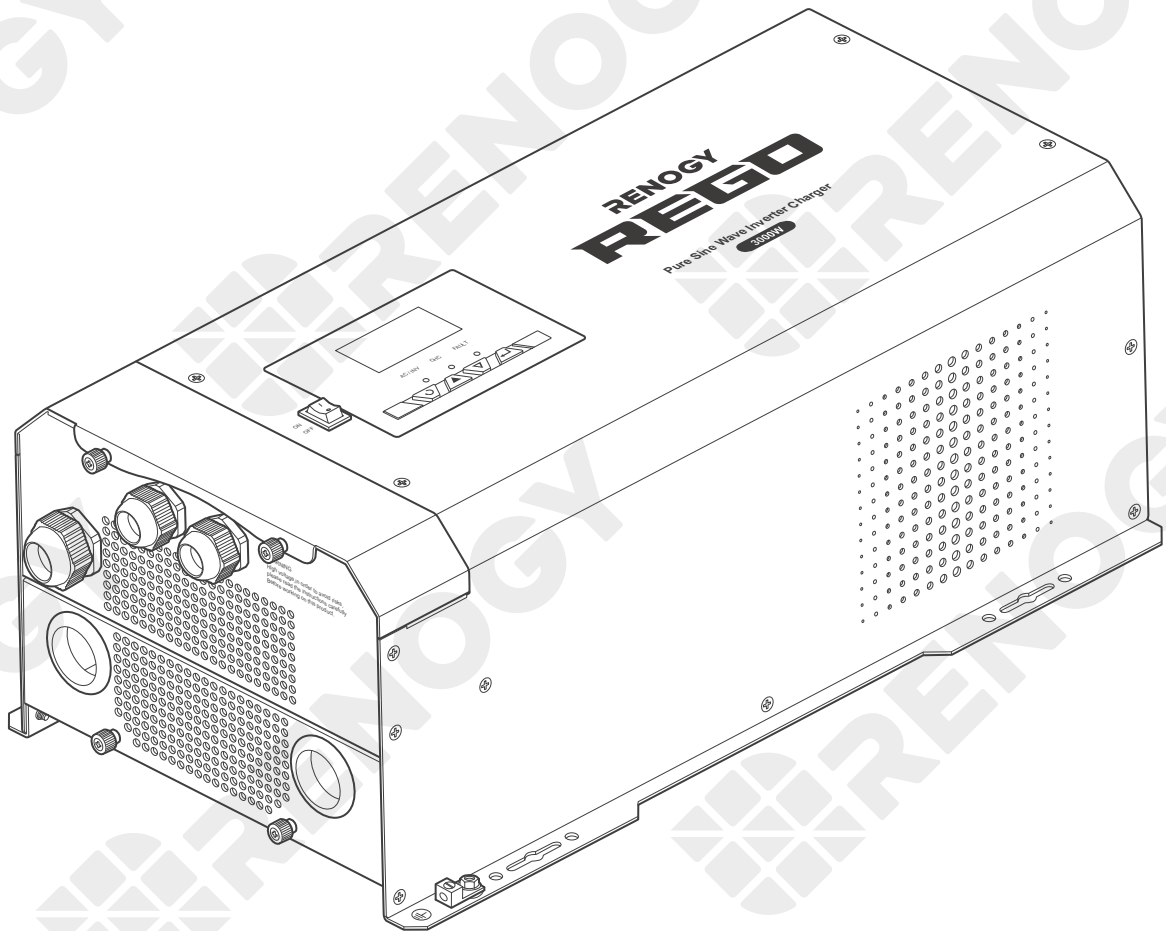

QUICK GUIDE



This Quick Guide contains important installation, operation, and maintenance instructions for REGO 12V 3000W Inverter Charger, hereinafter referred to as "Inverter Charger". Please read the Quick Guide carefully before using the device.

For additional support, contact our customer service through [renogy.com/contact-us/](https://renogy.com/contact-us/).



- The illustrations in this document are for demonstration purposes only. Details may appear slightly different depending on product revision and market region.



Visit [renogy.com](https://renogy.com) to find relevant documentation or get more support via "[Contact Us](#)".

**US** [www.renogy.com](https://www.renogy.com)

**CN** [www.renogy.cn](https://www.renogy.cn)

**UK** [uk.renogy.com](https://uk.renogy.com)

**CA** [ca.renogy.com](https://ca.renogy.com)

**AU** [au.renogy.com](https://au.renogy.com)

**JP** [renogy.jp](https://renogy.jp)

**FR** [fr.renogy.com](https://fr.renogy.com)

**DE** [de.renogy.com](https://de.renogy.com)

**ES** [es.renogy.com](https://es.renogy.com)

**KR** [kr.renogy.com](https://kr.renogy.com)

For detailed instructions,  
scan the QR code for the User Manual.



Your voice matters! Scan the QR code  
to submit your feedback on the product.



# Table of Contents

Package Contents .....	01
Product Overview .....	02
External View .....	02
Internal View .....	03
Wiring Diagram.....	04
Preparation.....	05
Components & Tools.....	05
Mounting Location .....	07
Mounting .....	08
Removing the Plate .....	08
Cautions.....	09
Ground Cable Wiring.....	10
Remote Control Wiring .....	11
Temperature Sensor Wiring.....	12
Battery Wiring.....	14
Device-side Wiring.....	14
Battery-side Wiring .....	15
AC Output Wiring.....	18
Device-side Wiring.....	18
Load Wiring.....	19
AC Input Wiring .....	21

Automatic Generator Start.....	23
Communication.....	24
Inter-Device Communication .....	24
Monitoring Device Communication .....	26
Putting Plates Back .....	28
Power on .....	29
Main Switch .....	29
Wired Remote Control .....	30
Operation.....	31
LCD.....	31
Setting Battery Type.....	35
Working .....	37
Power Off.....	39
Main Switch .....	39
Wired Remote Control .....	39
Overcurrent Protection .....	40
Maintenance.....	41





# Package Contents

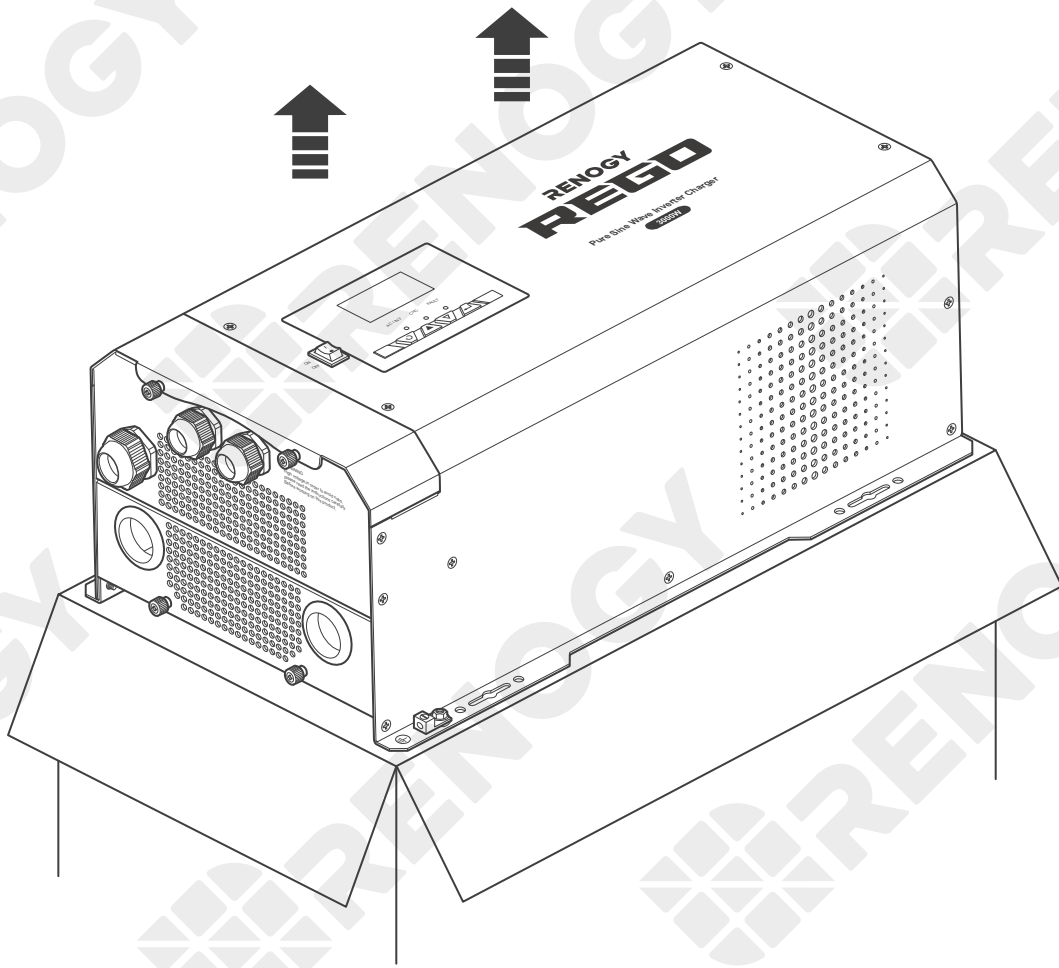

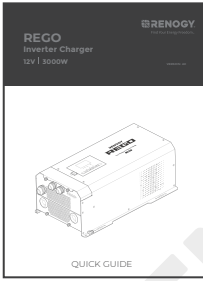
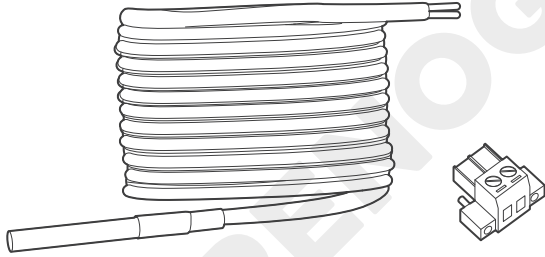
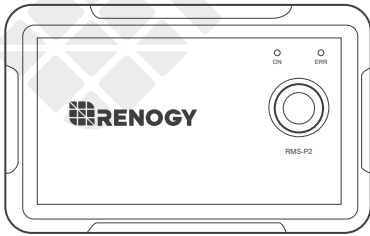
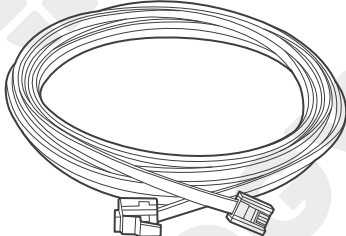
<p>Quick Guide × 1</p>	<p>Battery Temperature Sensor x 1</p>
	
<p>Wired Remote Control x 1</p>	<p>RJ11 Network Cable (5m) x 1</p>
	



# Product Overview

External View

Internal View

## External View

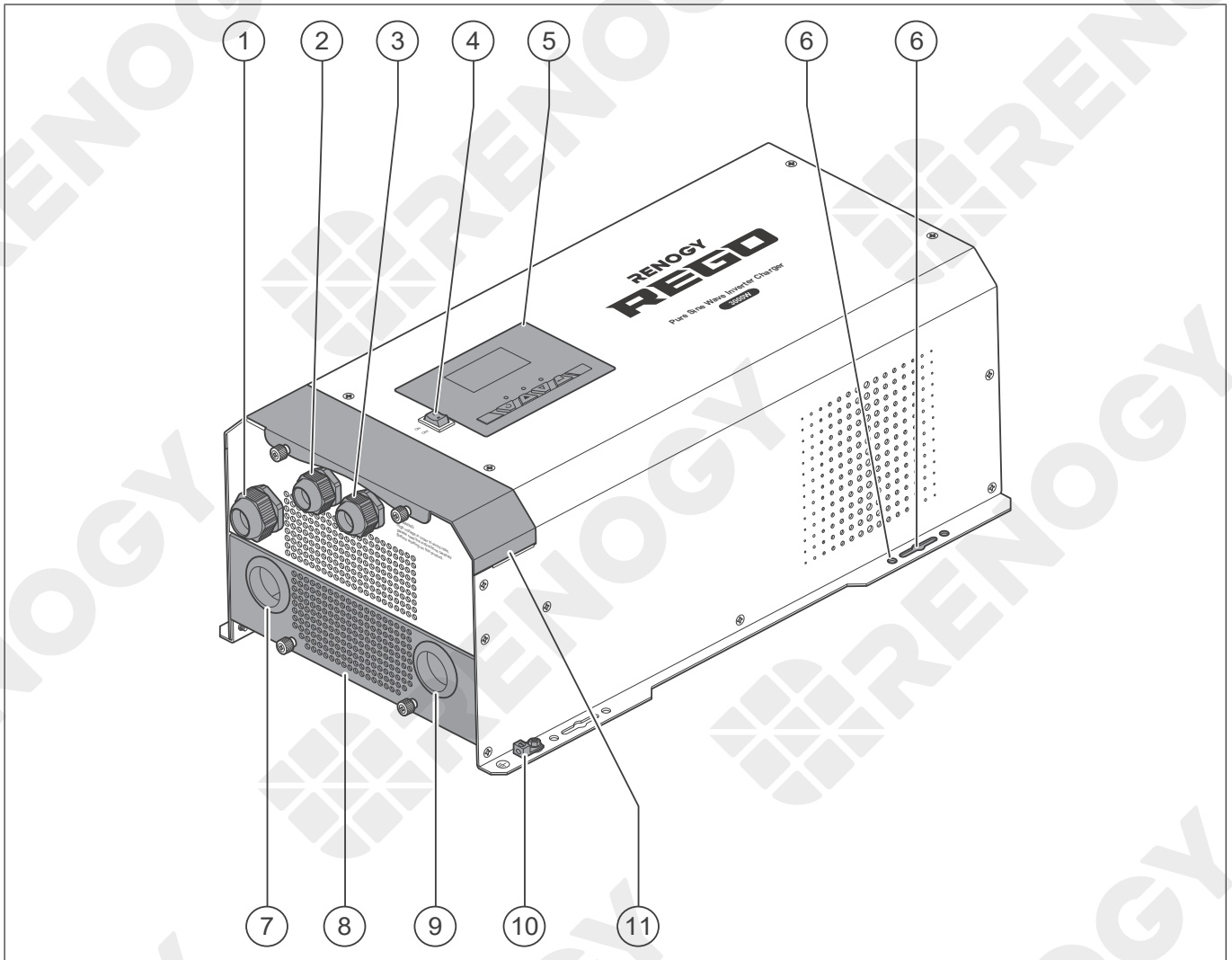

NO.	Part	NO.	Part
1	Remote & Accessory Cable Entry	7	DC Negative Battery Cable Entry
2	AC Output Cable Grommet	8	DC Cable Plate
3	AC Input Cable Grommet	9	DC Positive Battery Cable Entry
4	Main Power Switch	10	Chassis Ground Lug
5	LCD & Button Panel	11	Top Plate
6	Mounting Holes		



# Product Overview

External View

Internal View

## Internal View

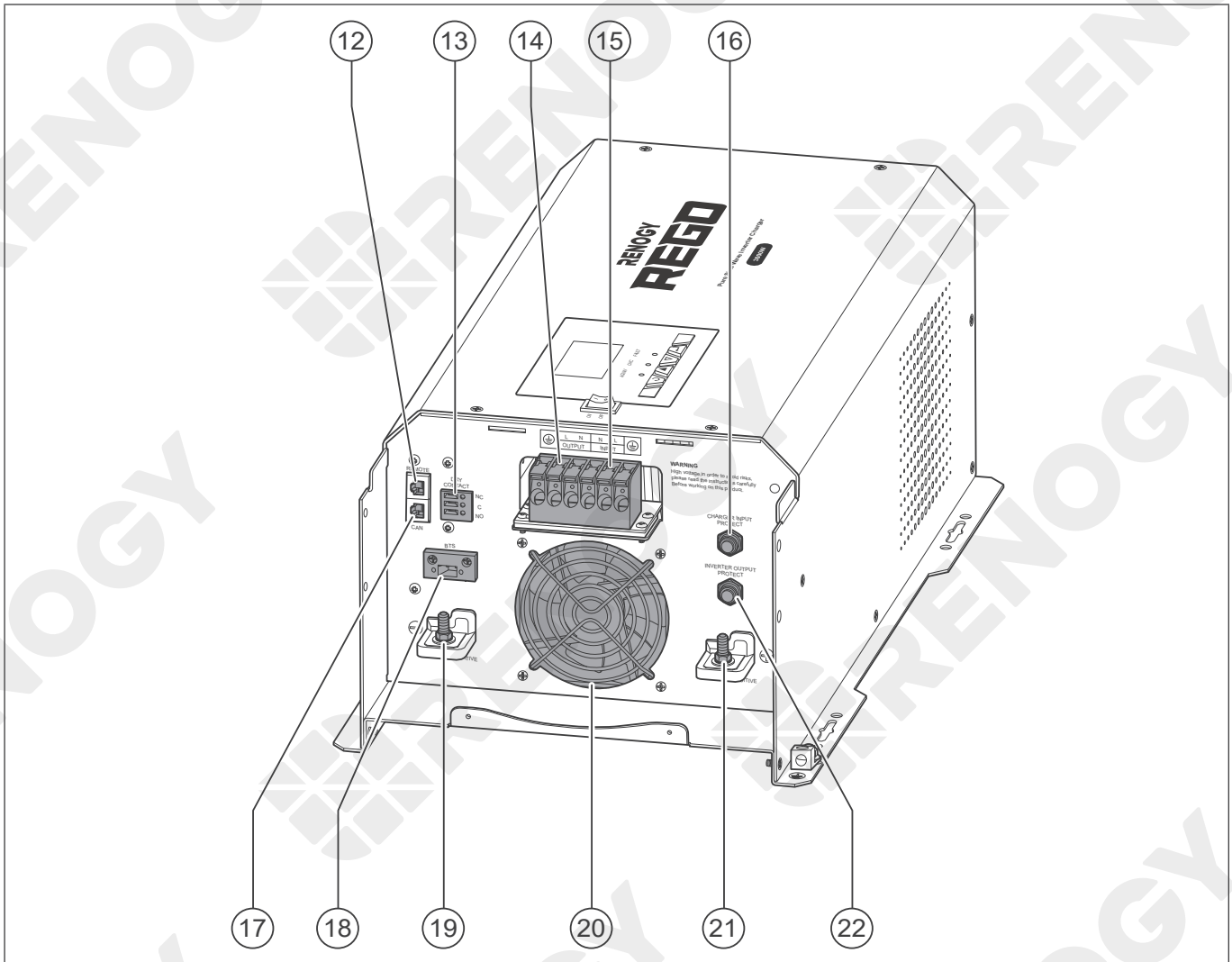

NO.	Part	NO.	Part
12	Wired Remote Port (REMOTE)	18	Battery Temperature Sensor (BTS) Port
13	Dry Contact Relay Terminal Block	19	DC Negative Battery Terminal
14	AC Output Lever Terminal Block	20	Fan
15	AC Input Lever Terminal Block	21	DC Positive Battery Terminal
16	Input Circuit Breaker	22	Output Circuit Breaker
17	Communication Port (CAN Bus)		



- Please inspect the inverter charger for any visible damage including cracks, dents, deformation, and other visible abnormalities. All connector contacts shall be clean, dry, and free of dirt and corrosion.
- No parts inside the inverter charger require maintenance or repair. Do not repair, tamper with, or modify components of the inverter charger.



# Wiring Diagram

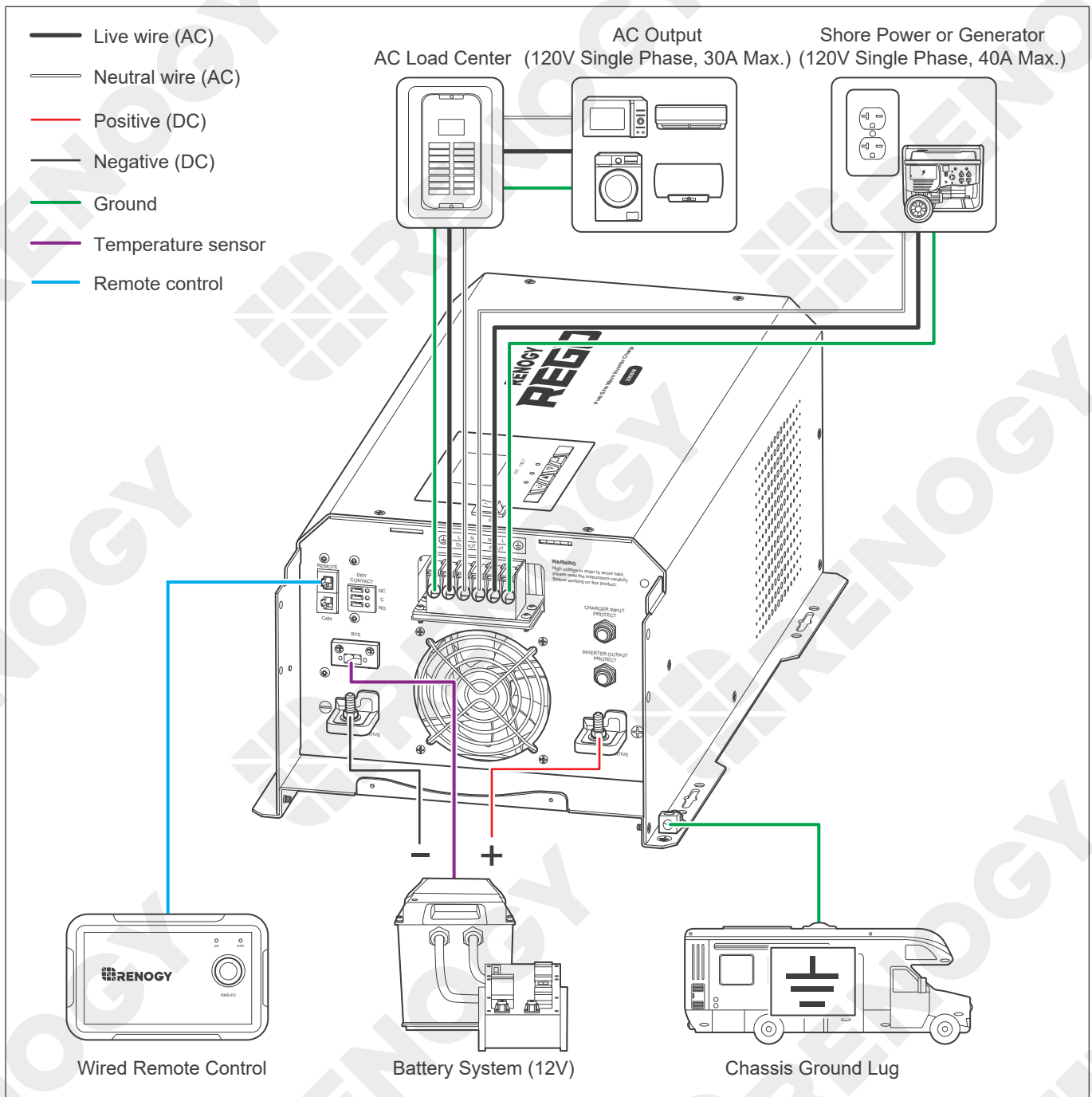

- All wiring should be done by qualified personnel to ensure compliance with all applicable installation codes and regulations.
- Please wear proper protective equipment and use insulated tools during installation.
- Risk of electric shock! Ensure that all power sources are disconnected before installation.
- Do not connect the AC Load Output to an AC Power Source such as generator or shore power. Otherwise, severe damage may occur.
- Do not use the temperature sensor on a LiFePO4 (LFP) battery which comes with a Battery Management System (BMS).



# Preparation

Components & Tools

Mounting Location

Mounting

Removing the Plate

Cautions

## Components & Tools

### Recommended Components

Battery Scenario A: REGO Battery Kit

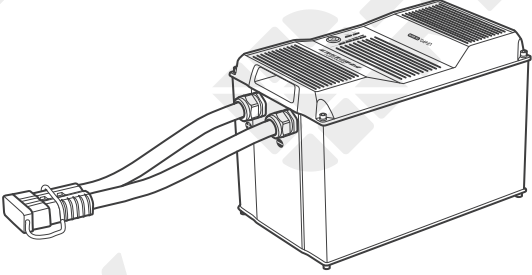
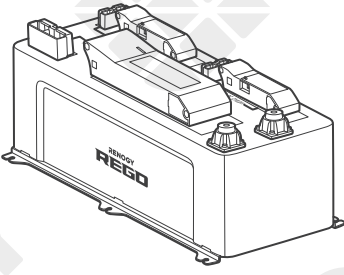
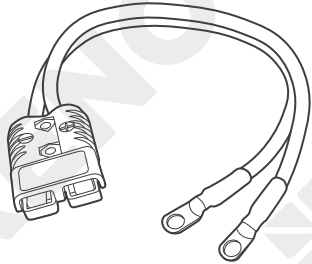
REGO 12V 400Ah Lithium Iron Phosphate Battery	REGO 4 Ports 400A System Combiner Box
	
Battery Adapter Cable 4/0 AWG (Anderson 350 Connector to Ring Terminal Adapter Cable)	
	

Battery Scenario B: Normal Battery Kit

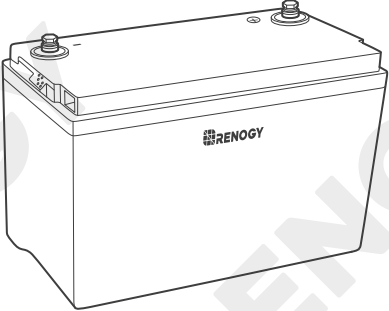
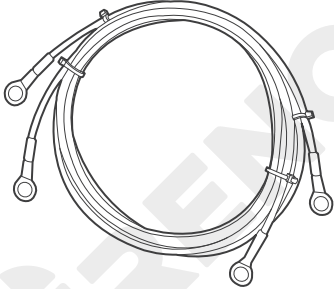
Normal Battery with +/- Bolts	Battery Inverter Cable 4/0 AWG
	

### Optional Accessories

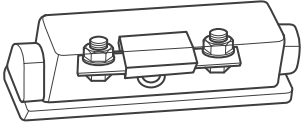
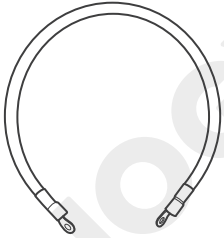
DC Fuse (400A)	Fuse Cable 4/0 AWG
	



# Preparation

Components & Tools





Mounting Location

Mounting

Removing the Plate

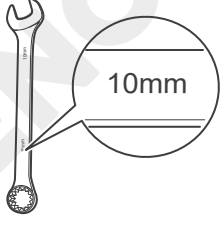
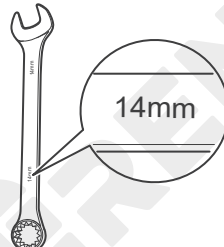
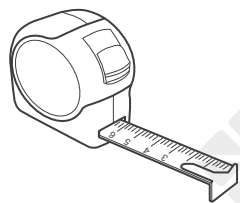
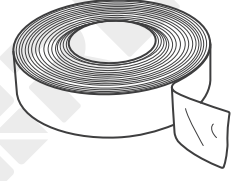
Cautions

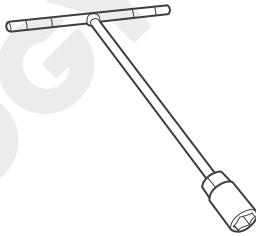
## Required Tools

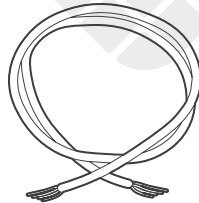
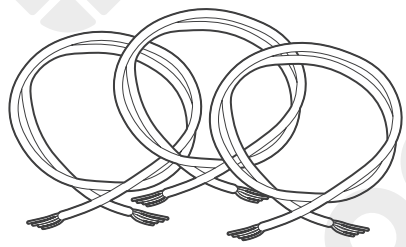
Wrench (10mm) 	Wrench (14mm) 	Measuring Tape 	Insulation Tape 
Phillips Screwdriver (6mm) 	Slotted Screwdriver (6mm) 	Socket Wrench (12mm) 	Wire Stripper 
Bare Wire			
Grounding (6 to 8 AWG) 		AC Output (10AWG) x 3 	



- The AC Output Cable Grommet has an inner diameter of 13mm. Properly select the AC cable size, ensuring it can run through the grommet.





# Preparation

Components & Tools

Mounting Location

Mounting

Removing the Plate

Cautions

## Mounting Location



- Risk of explosion! Never install the inverter charger in a sealed enclosure with flooded batteries! Do not install it in a confined area where battery gases can accumulate.
- Install the inverter charger as close to the battery as possible to avoid voltage drops due to long cables. It is recommended to use an adapter cable of a maximum of 15 meters. If the length of the adapter cable is insufficient, please re-select the installation site.
- Keep the inverter charger away from flammable liquids such as gasoline.
- Install the inverter charger on a flat surface indoors protected from direct sunlight, high temperature, and water. Make sure there is good ventilation.
- Do not install the inverter charger near flammable fumes or gases.
- Ensure that there is enough space to install the cable. Allow at least 10 inches of clearance at the fan and at least 7 inches around each side. It is better to have a larger ventilation gap. Do not obstruct the fan openings.
- The inverter charger can be fixed vertically (terminals facing down) to the wall or horizontally to the floor.

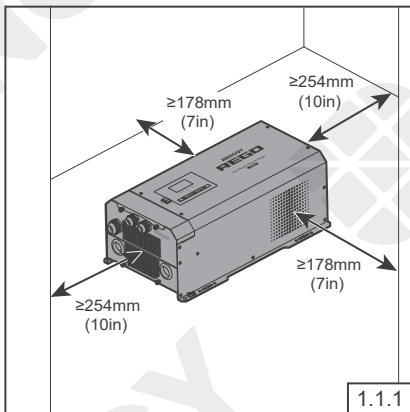

Plan the installation site.

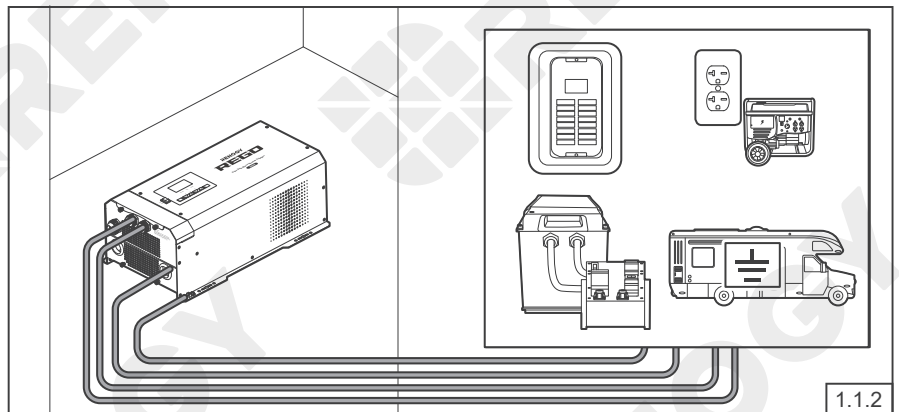

Measure the length of the adapter cable to see if it can be connected to the inverter charger.

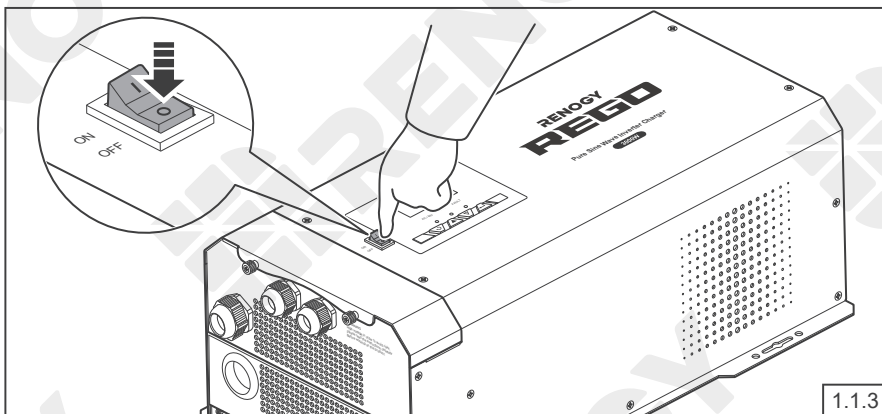

After the installation site is determined, please press the main switch of the inverter charger to the "OFF" position and keep it until the inverter charger is ready to be powered on.



# Preparation

Components & Tools

Mounting Location

Mounting

Removing the Plate

Cautions

## Mounting

### Recommended Accessories

Self-tapping Screws  
(M8 or M6)

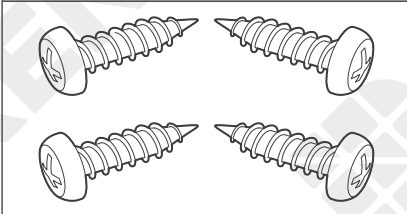

- Please choose proper self-tapping screws based on the installation site.
- Please make sure the inverter charger is firmly mounted on the installation site to prevent it from sliding or falling off.

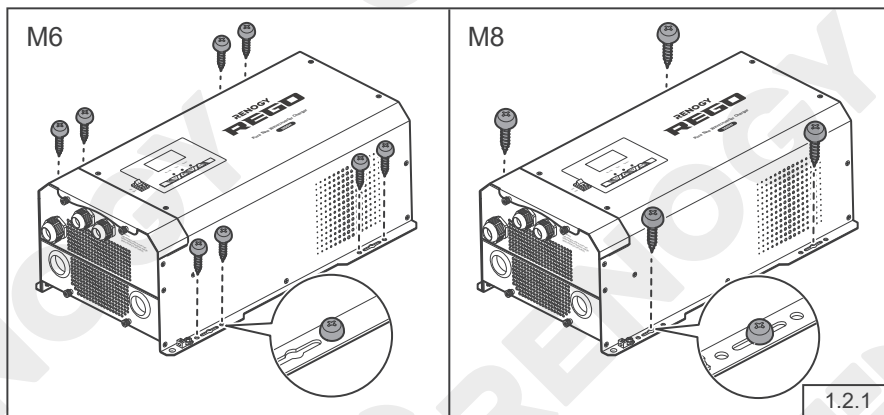

Align the inverter charger with the mounting position to fix it with self-tapping screws through the mounting holes.

## Removing the Plate

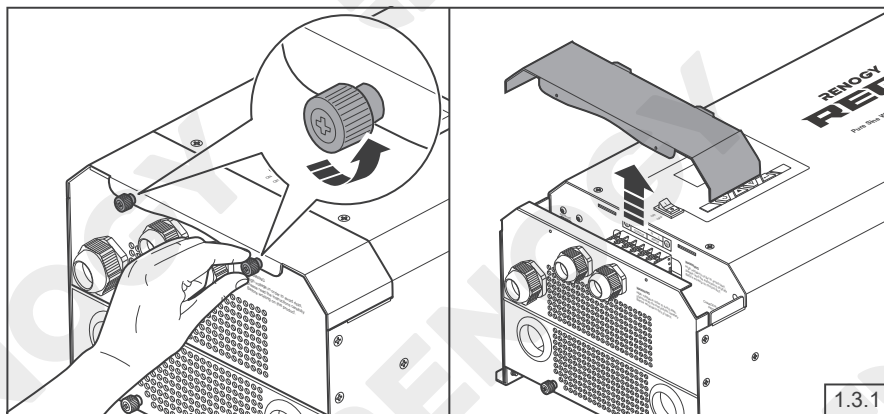

Turn the two upper panel screws counterclockwise by hand and remove the Top Plate. Alternatively, you can use a Phillips screwdriver.

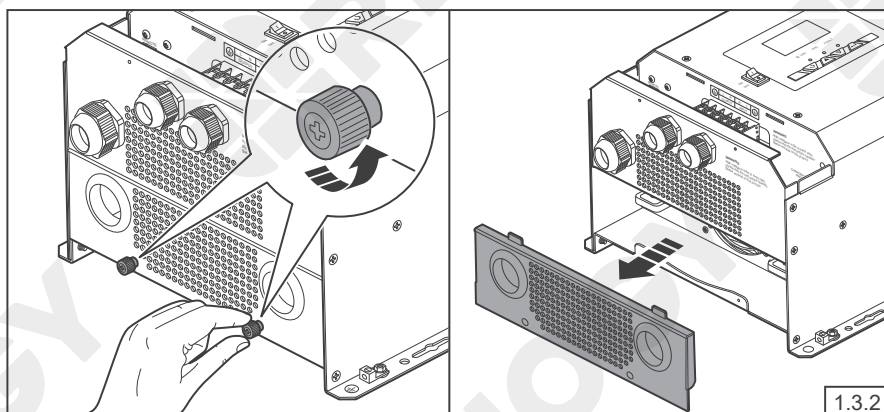

Turn the two lower panel screws counterclockwise by hand and remove the DC Cable Plate. Alternatively, you can use a Phillips screwdriver.





# Preparation

Components & Tools

Mounting Location

Mounting

Removing the Plate

Cautions

## Cautions



- Make sure that all adapter cables are not connected to any device before connection. If they are connected, make sure that all power devices are powered off.
- Confirm the polarity of the cable before connecting it to the auxiliary one. A reverse polarity contact will result in abnormalities. Damage caused by a reverse polarity contact voids the warranty.
- Please ensure that all ring terminals are securely connected.
- Color code and label all AC cables coming to/from the inverter charger. Use colored electrical tape or heat shrink tubing.
- Make sure all cables have a smooth bend radius and no kinks are present.



# Ground Cable Wiring



- Strip some insulation off the grounding cable by using a wire stripper according to the depth of the wiring hole.
- The torque of the cable retainer screw is 13.5N·m. Do not overtighten the screw to prevent damage.
- When connecting the inverter charger to the chassis ground lug of your RV, please consult the RV supplier to confirm the location of the chassis ground lug. A connection terminal can be installed if needed.

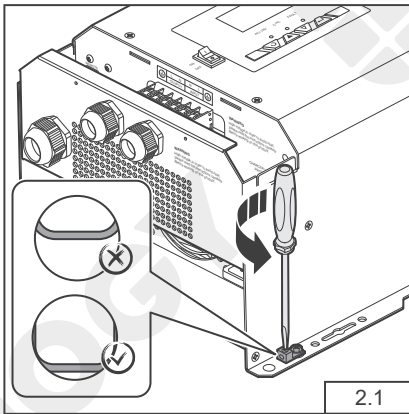

Turn the cable retainer screw for Chassis Ground Lug counterclockwise with a slotted screwdriver to ensure that the cable retainer is open.

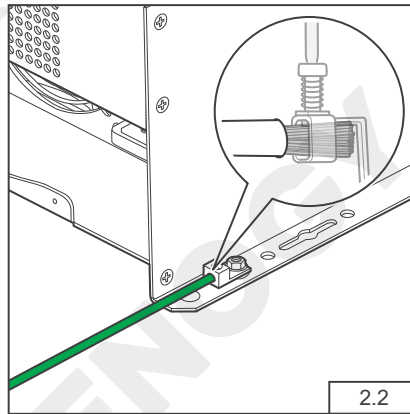

Insert one end of the bare wire into the wiring hole of the Chassis Ground Lug.

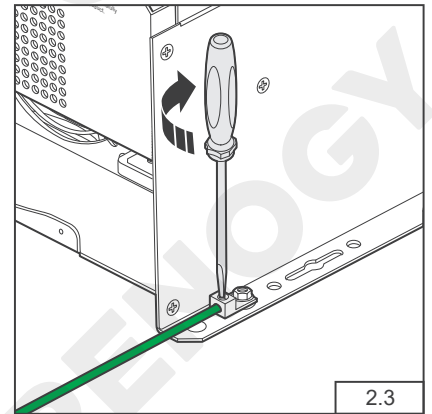

Tighten the cable retainer screw for Chassis Ground Lug clockwise with a slotted screwdriver to fasten the cable.

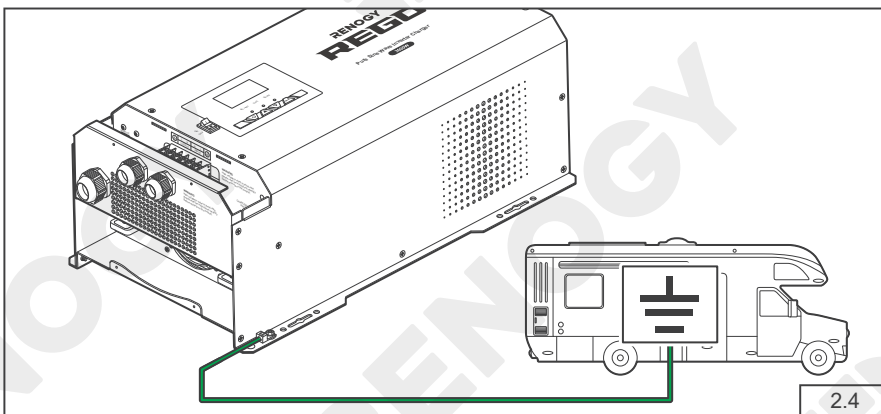

Connect the other end of the ground cable to the Chassis Ground Lug of the RV.



# Remote Control Wiring

You may choose to use the wired remote control of the inverter charger.

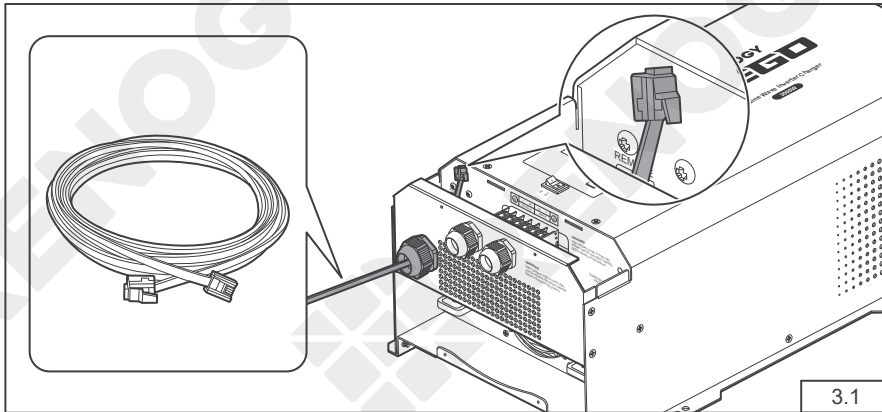

Run one end of the supplied RJ11 cable through the Remote & Accessory Cable Entry.

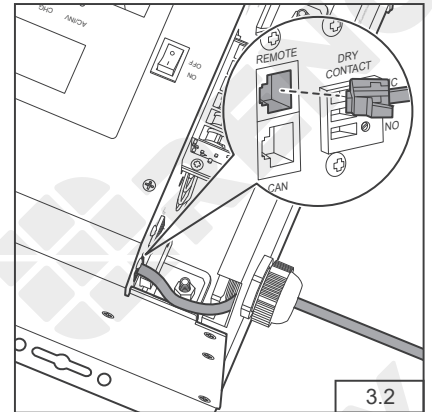

Connect the connector to Wired Remote Port (REMOTE).

Connect the connector on the other end of the RJ11 cable to the Wired Remote Control.

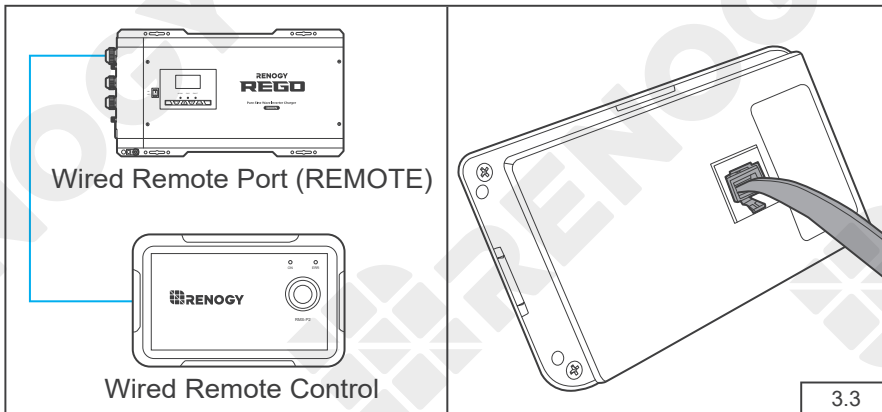



# Temperature Sensor Wiring

The temperature sensor measures the temperature of the battery and provides the inverter charger with a charge voltage calibration mechanism to ensure that the inverter charger can properly charge the battery within the operating temperature range from  $-20^{\circ}\text{C}$  to  $60^{\circ}\text{C}$  or  $-4^{\circ}\text{F}$  to  $140^{\circ}\text{F}$ .



- Do not use the temperature sensor on a LiFePO<sub>4</sub> (LFP) battery which comes with a Battery Management System (BMS).
- Strip some insulation off the grounding cable with a wire stripper.
- Do not overtighten the cable retainer screws; otherwise it will lead to stripped screws or screw bending.
- There is no requirement on polarity for temperature sensor cables.

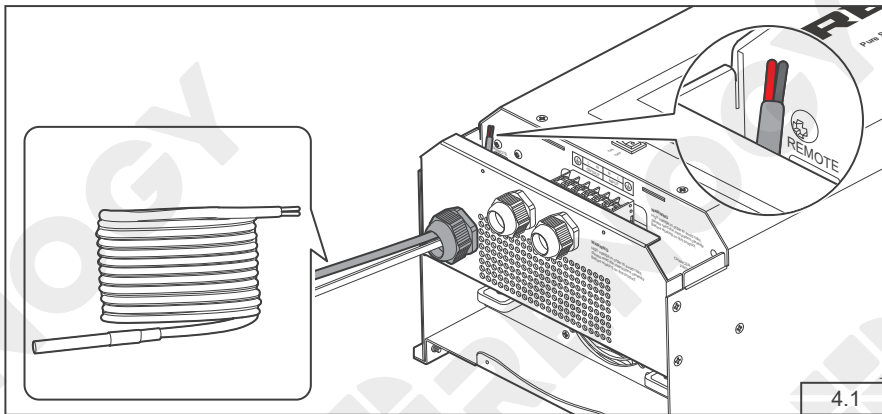

Run the bare terminal of the temperature sensor through Remote & Accessory Cable Entry.

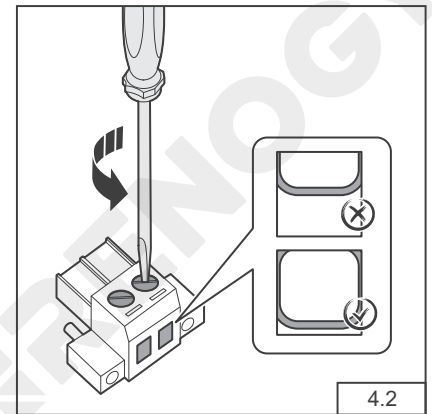

Turn the cable retainer screw for wire harness connector counterclockwise with a slotted screwdriver to ensure that the cable retainer is open.

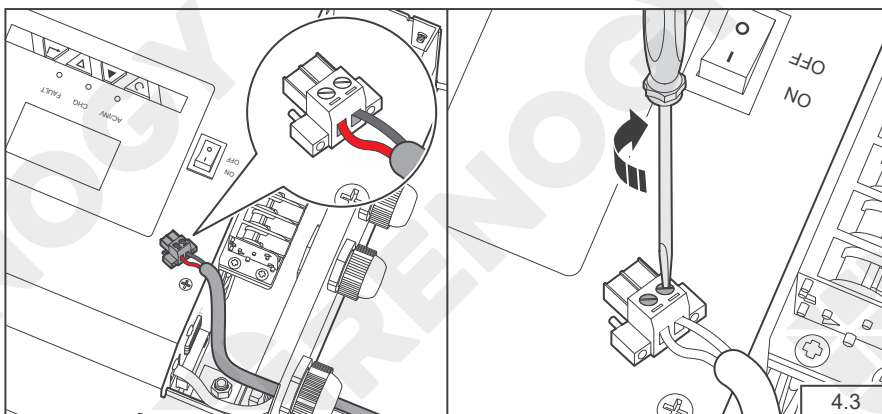

Insert the bare terminal of the temperature sensor into the harness connector and tighten it with a slotted screwdriver by turning the cable retainer screw for wire harness connector clockwise.

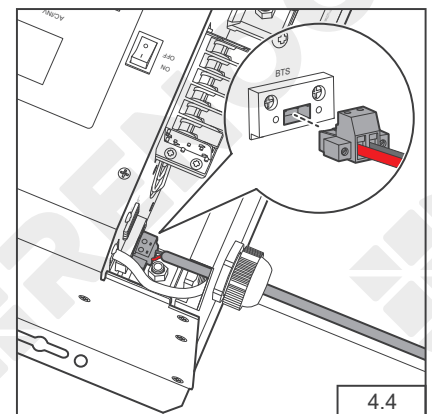

Plug the harness connector into the BTS Port of the inverter charger.



# Temperature Sensor Wiring

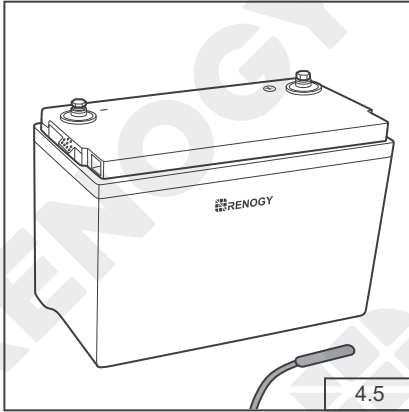

Place the temperature sensor near the inverter charger and fix it with a cable tie or insulation tape if necessary.



# Battery Wiring

Device-side Wiring

Battery-side Wiring

## Device-side Wiring



- The specification of DC Positive/Negative Battery Terminal is M8. Please select the appropriate ring terminal.
- The retaining nut torque of DC Positive/Negative Battery Terminal is 26N·m. Do not overtighten it to prevent damage.

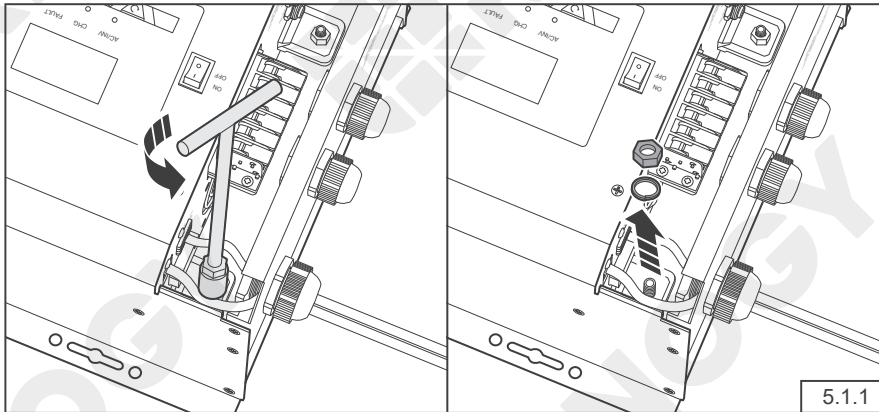

Remove the retaining nut of DC Negative Battery Terminal by turning it counterclockwise with a socket wrench and then remove the gasket.

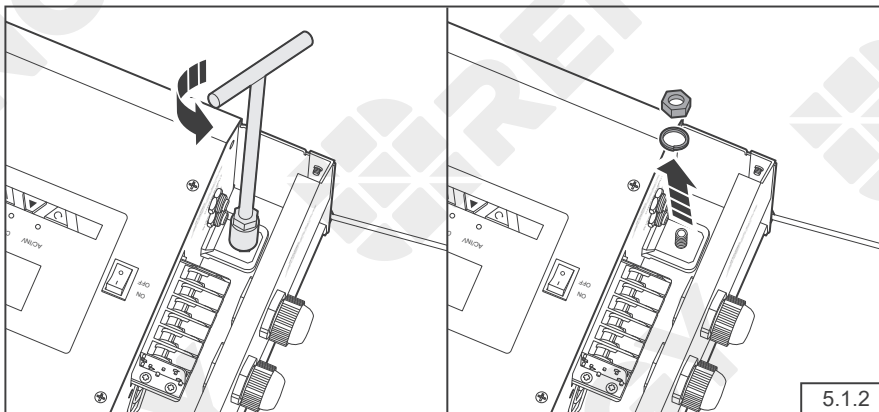

Remove the retaining nut of DC Positive Battery Terminal by turning it counterclockwise with a socket wrench and then remove the gasket.

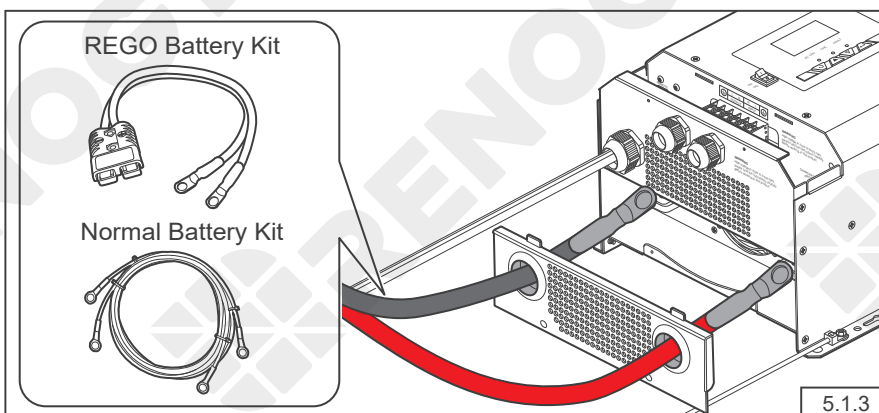

Insert the positive ring terminal of the battery adapter cable through DC Positive Battery Cable Entry of Removable DC Cable Entry, and the negative battery ring terminal through DC Negative Battery Cable Entry of DC Cable Plate.





# Battery Wiring

Device-side Wiring

Battery-side Wiring

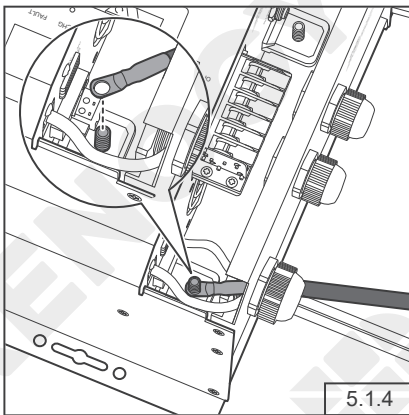

Connect the negative ring terminal to DC Negative Battery Terminal.

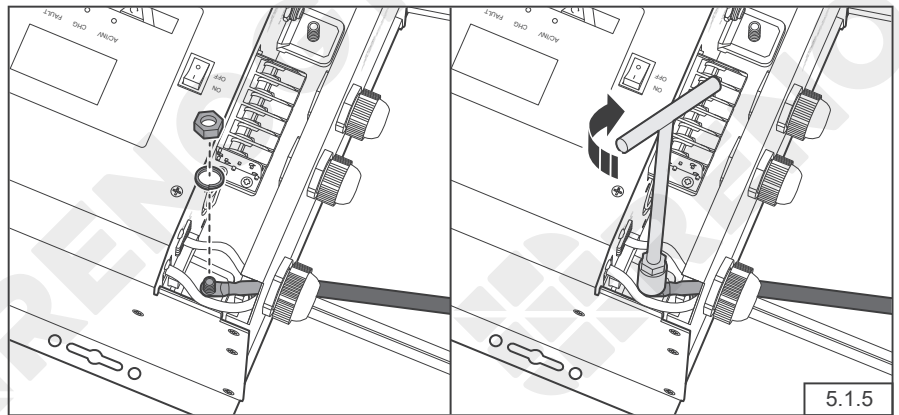

Install the gasket and retaining nut, and tighten the nut clockwise with a socket wrench.

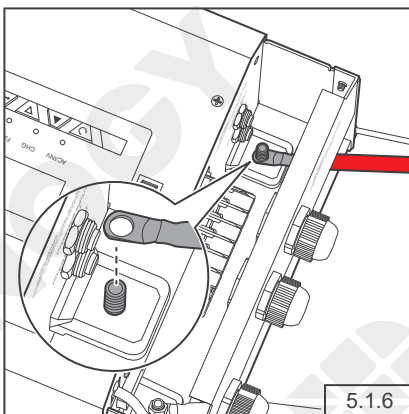

Connect the positive ring terminal to the DC Positive Battery Cable Entry.

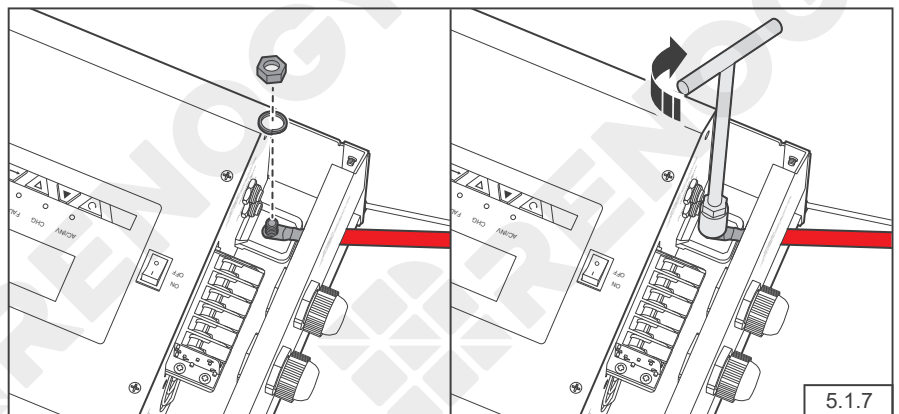

Install the gasket and retaining nut, and tighten the nut clockwise with a socket wrench.

## Battery-side Wiring



- This inverter charger only supports 12V batteries. Please read the user manual of the specific battery in use carefully to make sure the battery voltage is 12V before connection.
- Make sure the battery is disconnected from its power supply before connection.
- Identify the polarity (positive and negative) on the cables used for the inverter charger. A reverse polarity contact may damage the inverter charger. Damage caused by polarized connections voids the warranty.



# Battery Wiring

Device-side Wiring

Battery-side Wiring

## Battery Scenario A: REGO Battery Kit



- Please read the REGO 4 Ports 400A System Combiner Box User Manual carefully before connection.
- When connecting the combiner box to the inverter charger via the system hub of Anderson connector, install a 400A NH fuse in the top disconnection switch.
- If the inverter charger is connected to the System Combiner Box with a ring terminal adapter cable, please visit [renogy.com](https://www.renogy.com) for the user manual of the inverter charger.
- If the REGO 12V 400Ah Lithium Iron Phosphate Battery is wired with Positive/Negative Busbars, please visit [renogy.com](https://www.renogy.com) for the user manual of the inverter charger for wiring instructions.
- Ensure tight fit of Anderson connectors during installation.

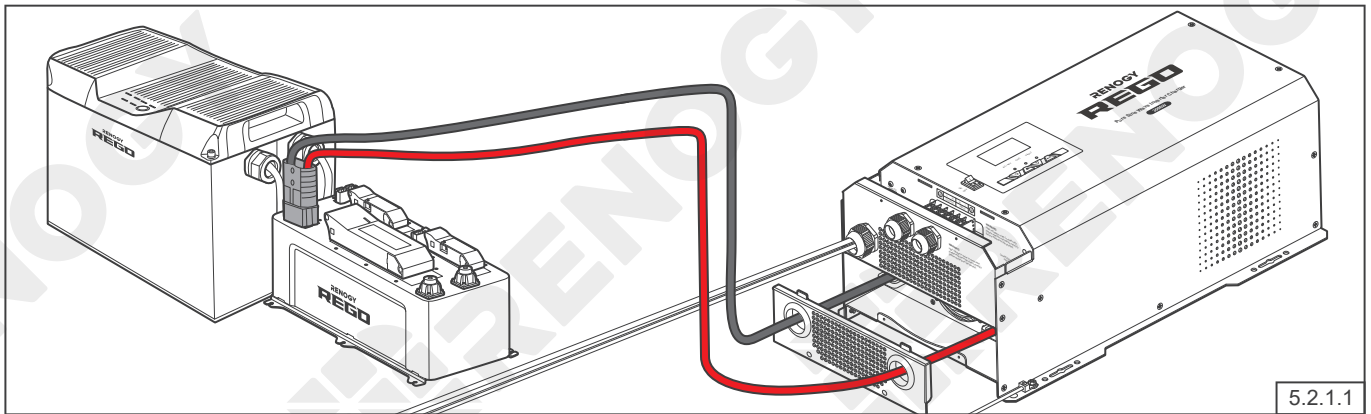

Connect Anderson 350 connector of battery adapter cable to System Combiner Box.





# Battery Wiring

Device-side Wiring

Battery-side Wiring

## Battery Scenario B: Normal Battery Kit



- Select the appropriate wrench according to the specification of the positive/negative wire retaining bolt of the system hub.
- Please ensure that the ring terminals are securely connected.

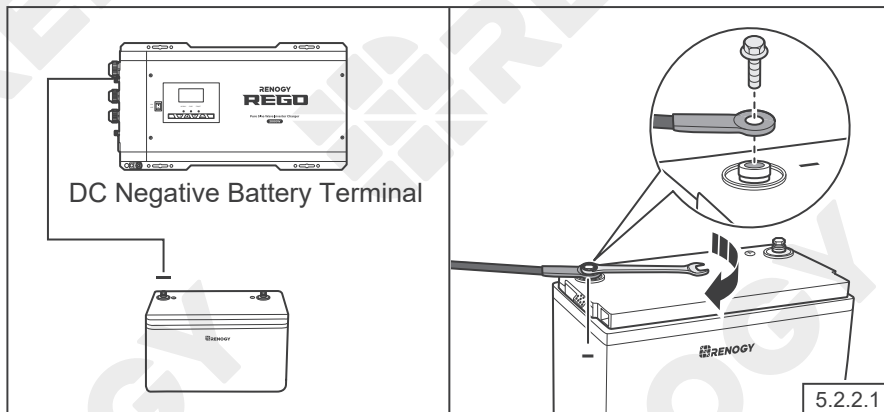

Connect the negative ring terminal of the adapter cable of the inverter charger to the negative terminal of a Normal Battery. Please tighten the wire retaining bolt with a wrench.

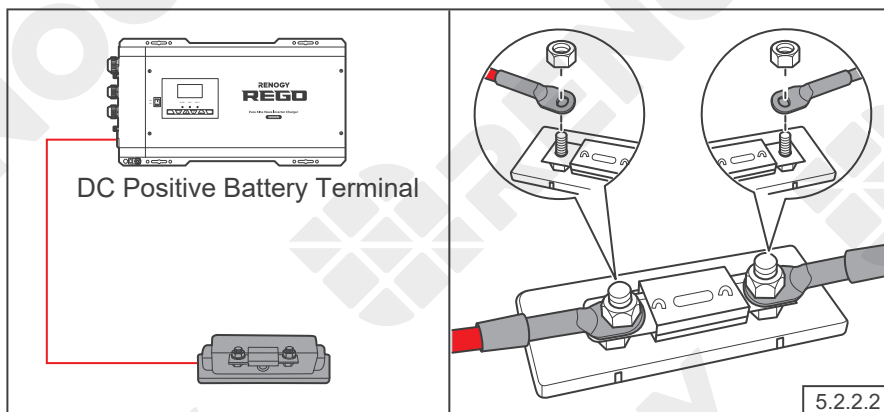

For your safety, it is recommended to use a battery fuse (400A). Connect the positive ring terminal of the inverter charger adapter cable to the battery fuse. Install the fuse wire on the other end of the fuse.

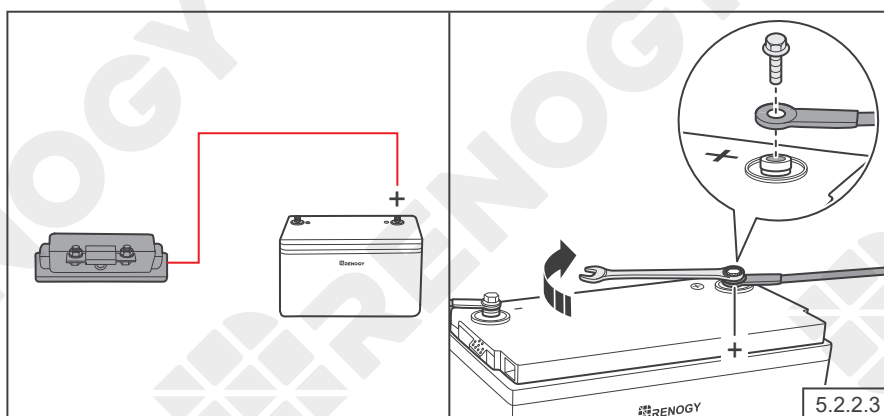

The ring terminal on the other end of the fuse wire is connected to the positive terminal of the Normal Battery. Tighten the wire retaining bolt clockwise with a wrench.



# AC Output Wiring

Device-side Wiring

Load Wiring

## Device-side Wiring



- Strip 10mm of insulation off the AC Output cable with a wire stripper.

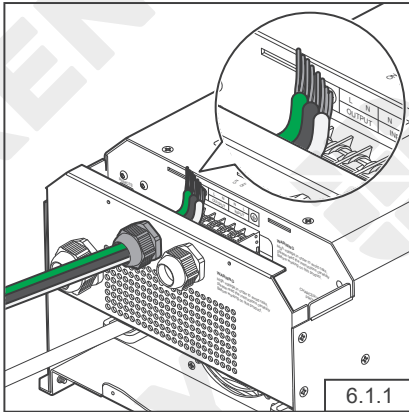

Run 3 bare wires through AC Output Lever Terminal Block.

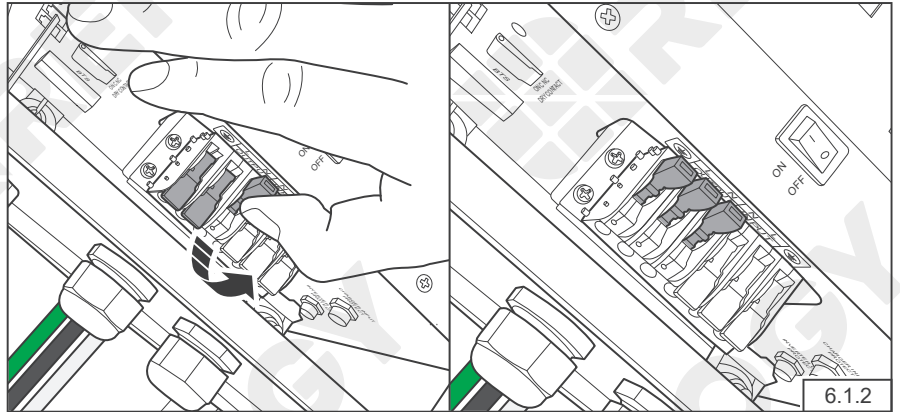

Push up the switches of the wire harness retainer of AC Output Lever Terminal Block.

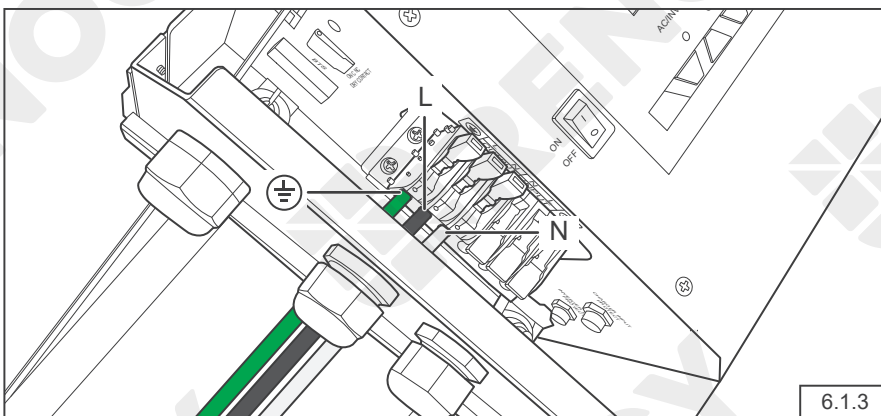

Connect the live wire to the (L) terminal hole, the neutral wire to the (N) terminal hole, and the ground wire to the (⊕) terminal hole.

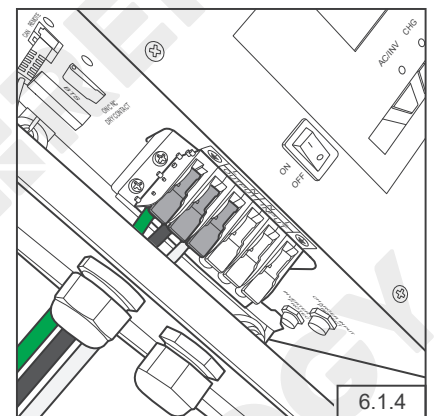

Press down the wire harness retainer of AC Output Lever Terminal Block.



# AC Output Wiring

Device-side Wiring

Load Wiring

## Load Wiring

### Recommended Accessories

AC Distribution Box and  
AC Circuit Breaker

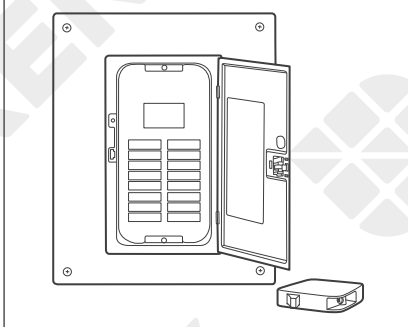

- For your safety, it is recommended that qualified electricians familiar with safety codes of electrical systems perform the installation.
- Please read the user manual of AC distribution box carefully before installation.

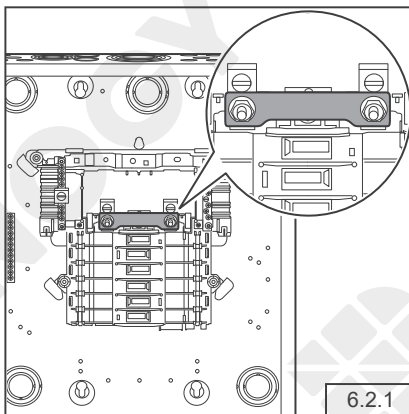

Remove the front cover of the power distribution box and connect the two live wire busbars with a copper strip.

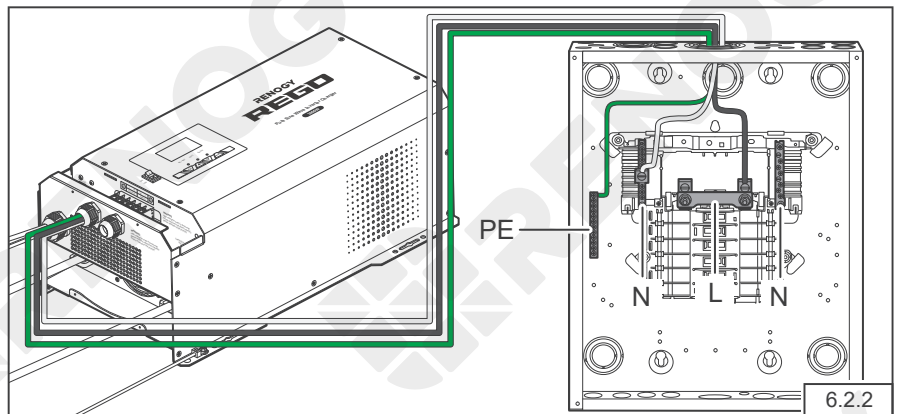

Connect the AC Output cable of the inverter charger to the distribution box. The live wire is connected to the (L) terminal. The neutral wire is connected to the (N) busbar. And the ground wire is connected to the (PE) busbar.

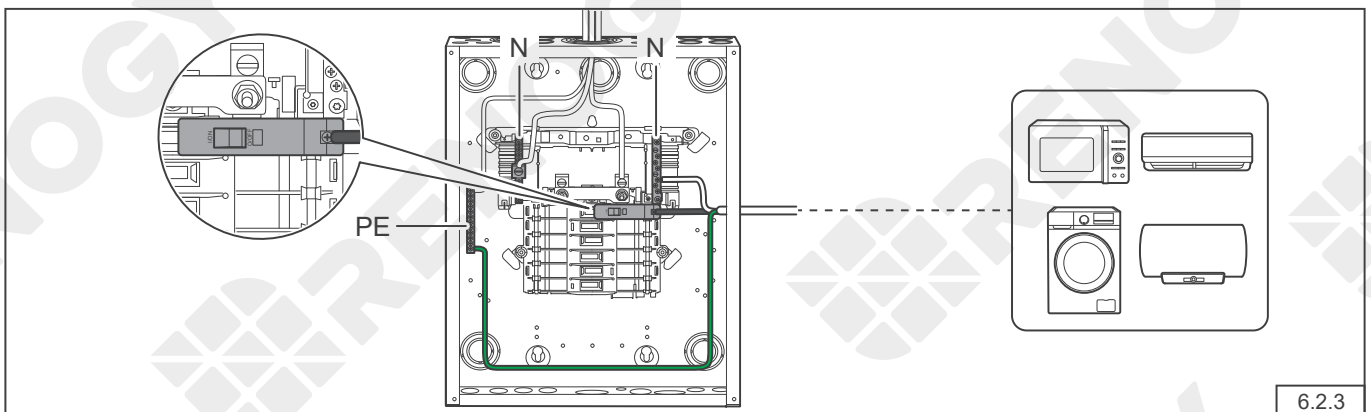

Select an appropriate circuit breaker according to the operating load current, and connect the load to the distribution box. Connect the live wire to the (L) terminal hole, the neutral wire to the (N) terminal hole, and the ground wire to the (PE) busbar.



# AC Output Wiring

Device-side Wiring

Load Wiring

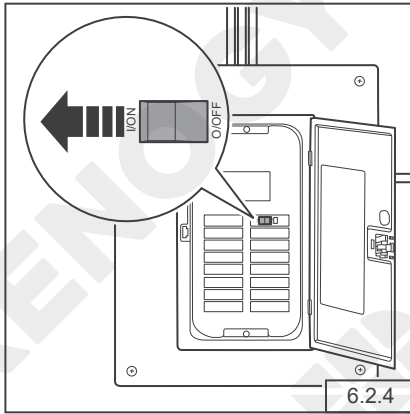

Install the front cover of the distribution box and turn on all the circuit breakers in the distribution box.



# AC Input Wiring

The AC input is optionally installed on demand.



- Please make sure the current of the AC input is no greater than 40A; otherwise, the inverter charger cannot work.
- Risk of electric shock! Make sure the Shore Power or Generator is disconnected during connection.
- Do not connect the AC input to any other terminal blocks except the AC Input Lever Terminal Block; otherwise the inverter charger will be damaged.
- The specification of AC input cable is at least 8AWG.
- Strip 10mm of the insulation off the AC input cable with a wire stripper.
- The AC Input Cable Grommet has an inner diameter of 13mm. Properly select the AC cable size, ensuring that three bare wires can run through the grommet at the same time.
- When connecting AC Generator, please read the user manual of AC Generator for wiring instructions.

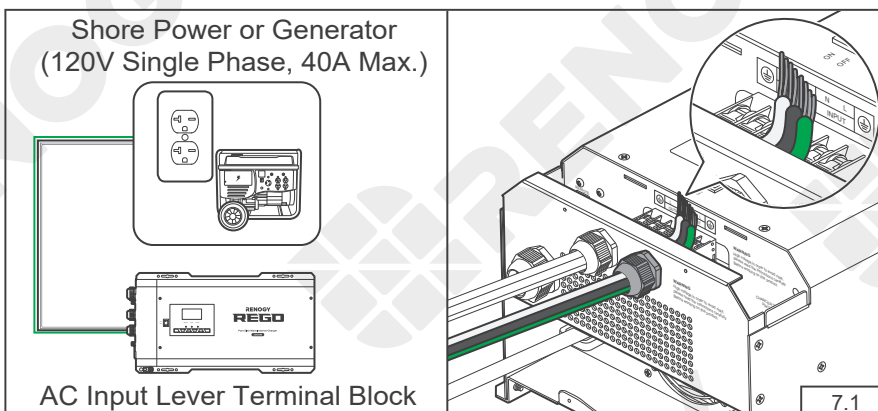

Run the AC power cable through AC Input Cable Grommet.

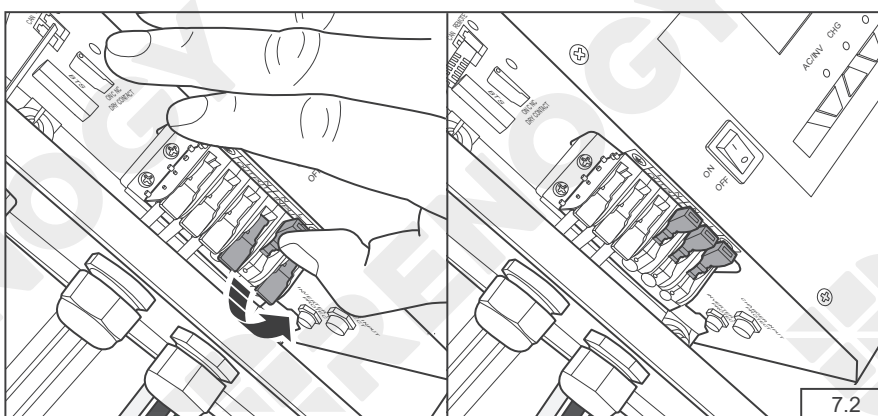

Push up the switch of the harness retainer of AC Input Lever Terminal Block.



# AC Input Wiring

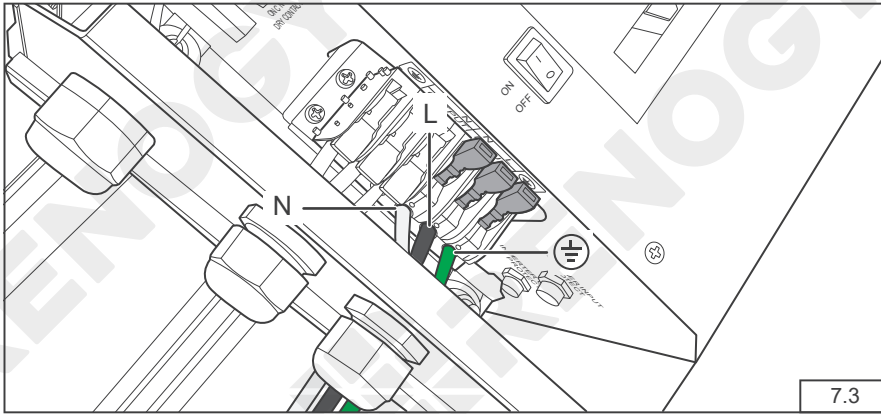

Connect the live wire to the (L) terminal hole, the neutral wire to the (N) terminal hole, and the ground wire to the (⊕) terminal hole.

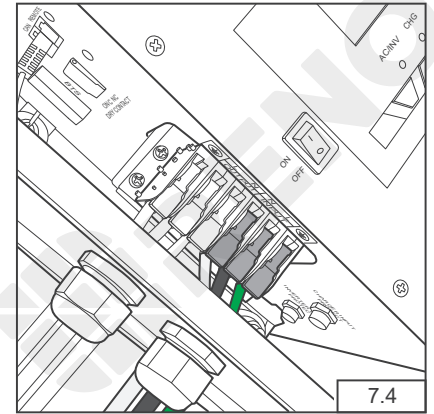

Press down the switch of the harness retainer of the AC Input Lever Terminal Block.





# Automatic Generator Start

If the inverter charger is connected to an AC Power Supply (AC Generator) and the generator can automatically start/stop, it is recommended to connect the generator to the Dry Contact Relay Terminal Block with a signal cable.

When the voltage of the inverter charger is lower than the set voltage in program 96, the inverter charger will automatically start the generator and charge the battery while the load is supplied by the generator. When the voltage of the inverter charger is higher than the set value, the inverter charger will automatically shut down the generator.



- You can set the voltage of the inverter charger in program 96. The voltage should be set after the inverter charger is turned on. Please finish the installation of the inverter charger first. For details, please visit [renogy.com](http://renogy.com) for the user manual.
- Please read the user manual of the generator carefully before connection. Make sure the generator can automatically start/stop. Identify NC (normally closed contact), NO (normally open contact), and C (common static contact) of the generator and ensure signal lines are connected properly.
- Some generators only have NC (normally closed contact) and C (common static contact) or NO (normally open contact) and C (common static contact). You can connect them on demand.
- Do not store the inverter charger with auto gen start feature enabled. Generators exhaust dangerous fumes when running.

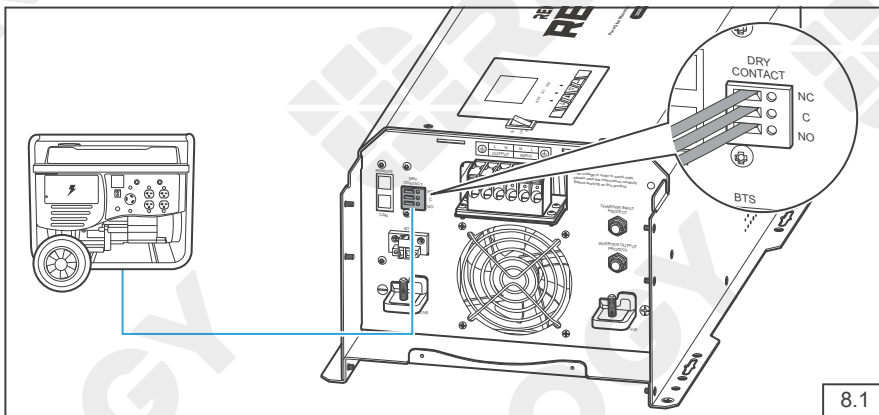

If your generator has an automatic start/stop function, you can connect the generator to NC, C, and NO wiring holes corresponding to Dry Contact Relay Terminal Block of the inverter charger via a signal cable. For details, please visit [renogy.com](http://renogy.com) for the user manual.

If your inverter charger uses the DC Generator as the power supply and the DC Generator can automatically start/stop, you can connect the DC Generator to the inverter charger via the signal line. The inverter charger will automatically start and stop the generator according to the voltage you set. The signal line is connected in the same way as the AC Generator.



- Make sure that the DC Generator is properly connected to the inverter charger.



The communication connection is optional. The REGO Inverter Charger can communicate with other REGO devices and monitoring devices, enabling safe operation, smart control, remote monitoring, and programmable settings.

## Inter-Device Communication

Depending on the installation condition, the RV-C communication connections between the inverter charger and other REGO devices can be established with backbone or daisy chain topology. The inter-device communication allows the inverter charger to dynamically adjust the charging profile for an optimal and safe charge.

### Backbone Topology

If an RV-C bus is pre-installed in the RV, check the network wiring diagram provided by the RV manufacturer and follow the backbone topology for the RV-C communication connections. For more details, please read the user manual of the inverter charger at [renogy.com](http://renogy.com).

### Daisy Chain Topology

If the RV-C bus is not available, follow the daisy chain topology for the communication connections.



- Risk of electric shock! Turn off the inverter charger and the power supply devices connected to the inverter charger during connection.
- Please wear proper protective equipment and use insulated tools during operation. Be careful when touching bare terminals of capacitors as they may retain high lethal voltages even after power is removed.
- Do not place the inverter charger at the top or bottom of the daisy chain network.

### Recommended Accessories

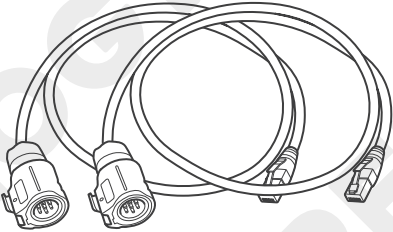
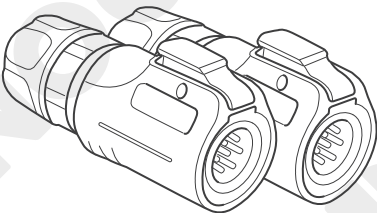
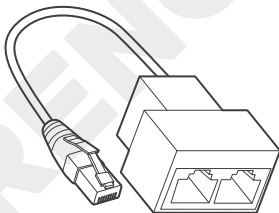
LP16 Plug (7-Pin) to RJ45 Communication Adapter Cable	LP16 Terminator Plug (7-Pin)	RJ45 Network 1 to 2 Port Ethernet Adapter Splitter
		





# Communication

Inter-Device Communication

Monitoring Device Communication

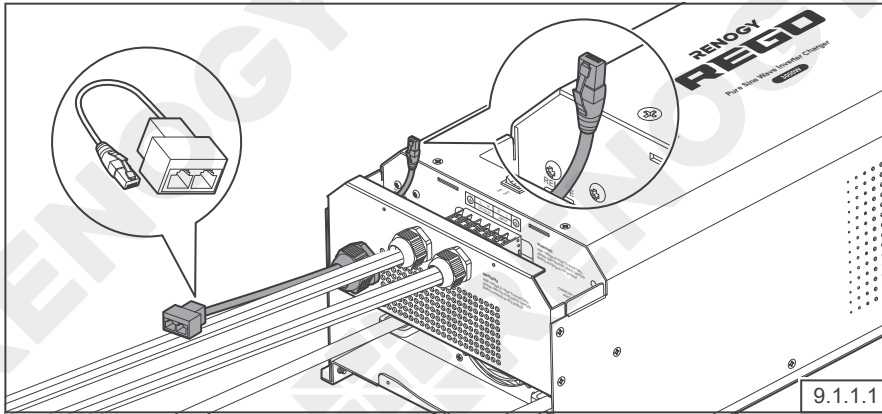

Insert the RJ45 connector of RJ45 Network 1 to 2 Port Ethernet Adapter Splitter through Remote & Accessory Cable Entry.

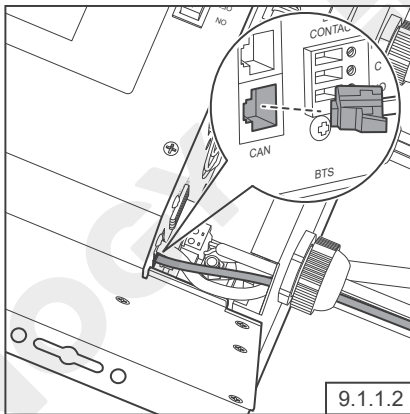

Connect the RJ45 connector to the Communication Port (CAN Bus).

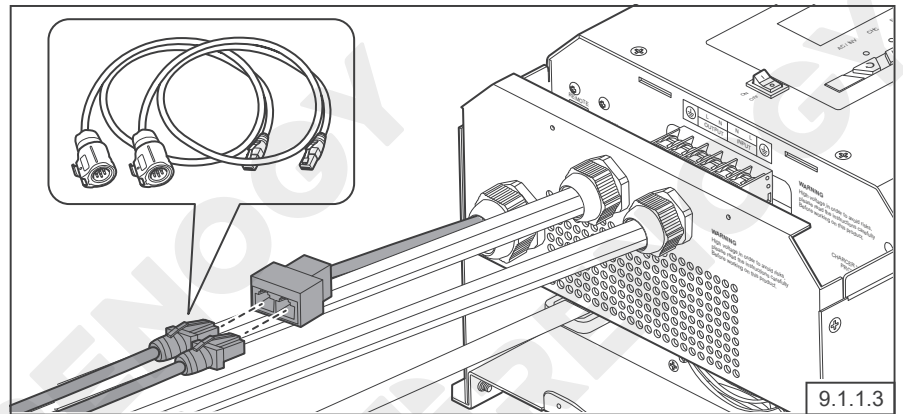

Connect the two RJ45 connectors of LP16 Plug (7-Pin) to RJ45 Communication Adapter Cables to the RJ45 Network 1 to 2 Port Ethernet Adapter Splitter.

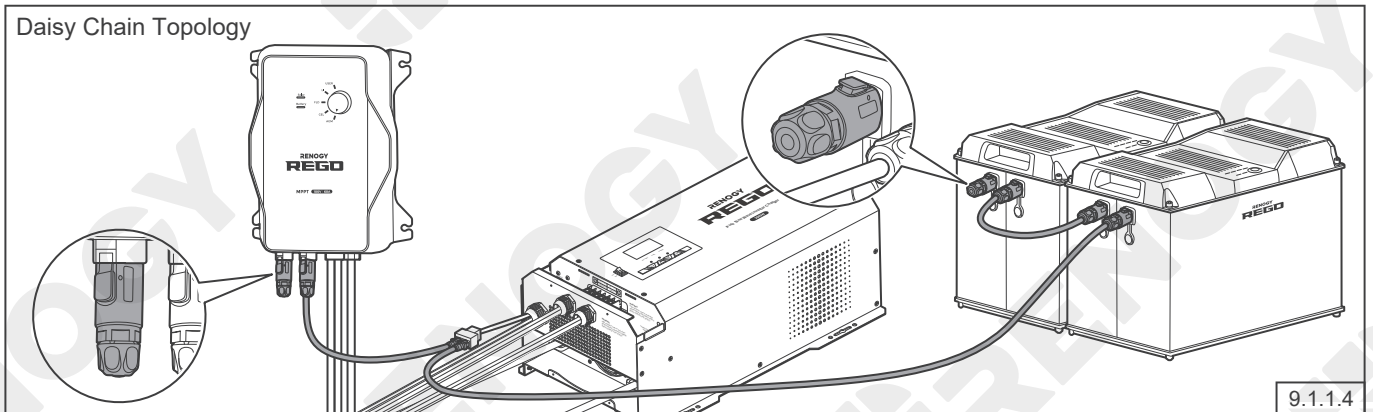

**Daisy Chain Topology**  
Connect the other ends of the LP16 Plug (7-Pin) to RJ45 Communication Adapter Cables to the vacant CAN communication ports of other REGO series devices. Insert the terminal plugs (sold separately) into the vacant CAN communication port of the first and last REGO devices.



# Communication

Inter-Device Communication

Monitoring Device Communication

## Monitoring Device Communication

Depending on the application, the short-range or long-range communication connections can be established between the inverter charger and monitoring devices. The monitoring device allows for the monitoring and programming of the inverter charger or even the complete system.



- Please scan the QR code on the last page of the Quick Guide to download the DC Home app.
- Please make sure that the inverter charger is turned on before the connection.

### Short-Range Monitoring

If only short-range monitoring is required, connect the inverter charger to the DC Home app directly through Bluetooth.

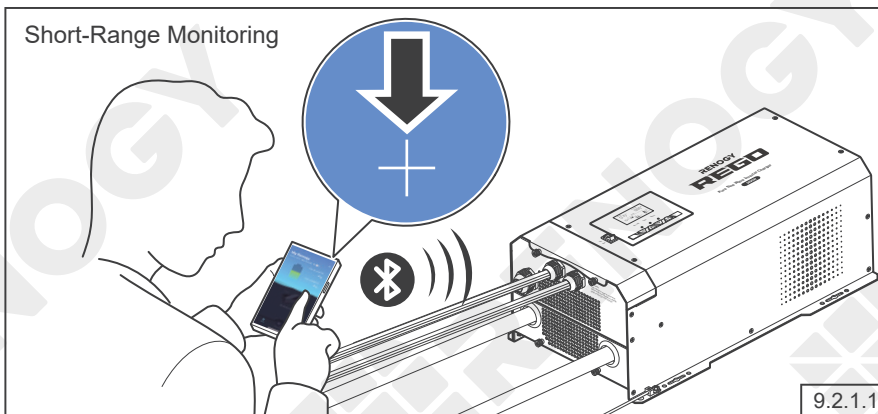

Tap "+" to search for new devices. Add the newly found inverter charger to the device list. Monitor the inverter charger on the device page.

### Long-Range Monitoring

If long-range communication and programming are required, connect the inverter charger to Renogy ONE through Bluetooth or wires, and the Renogy ONE to the DC Home app through Wi-Fi.



- Please make sure that the Renogy ONE is powered on before the connection. Please read the user manual of Renogy ONE at [renogy.com](http://renogy.com) before the connection.

### Recommended Accessories

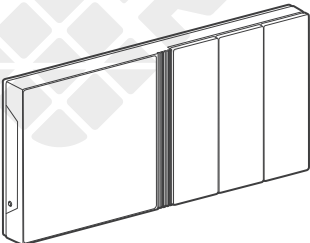
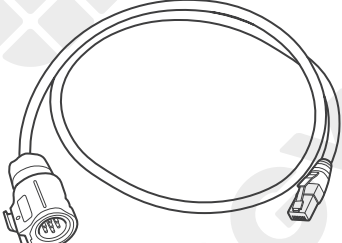
Renogy ONE	LP16 Plug (7-Pin) to RJ45 Communication Adapter Cable
	



# Communication

Inter-Device Communication

Monitoring Device Communication

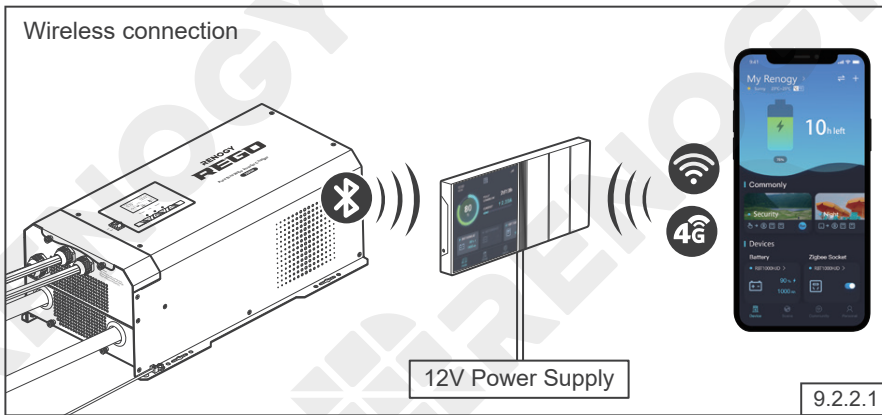

If the inter-device communication is not established, connect the inverter charger to the Renogy ONE (sold separately) through Bluetooth, and bind the Renogy ONE to the DC Home app through Wi-Fi. Monitor the inverter charger on the Renogy ONE or the DC Home app.

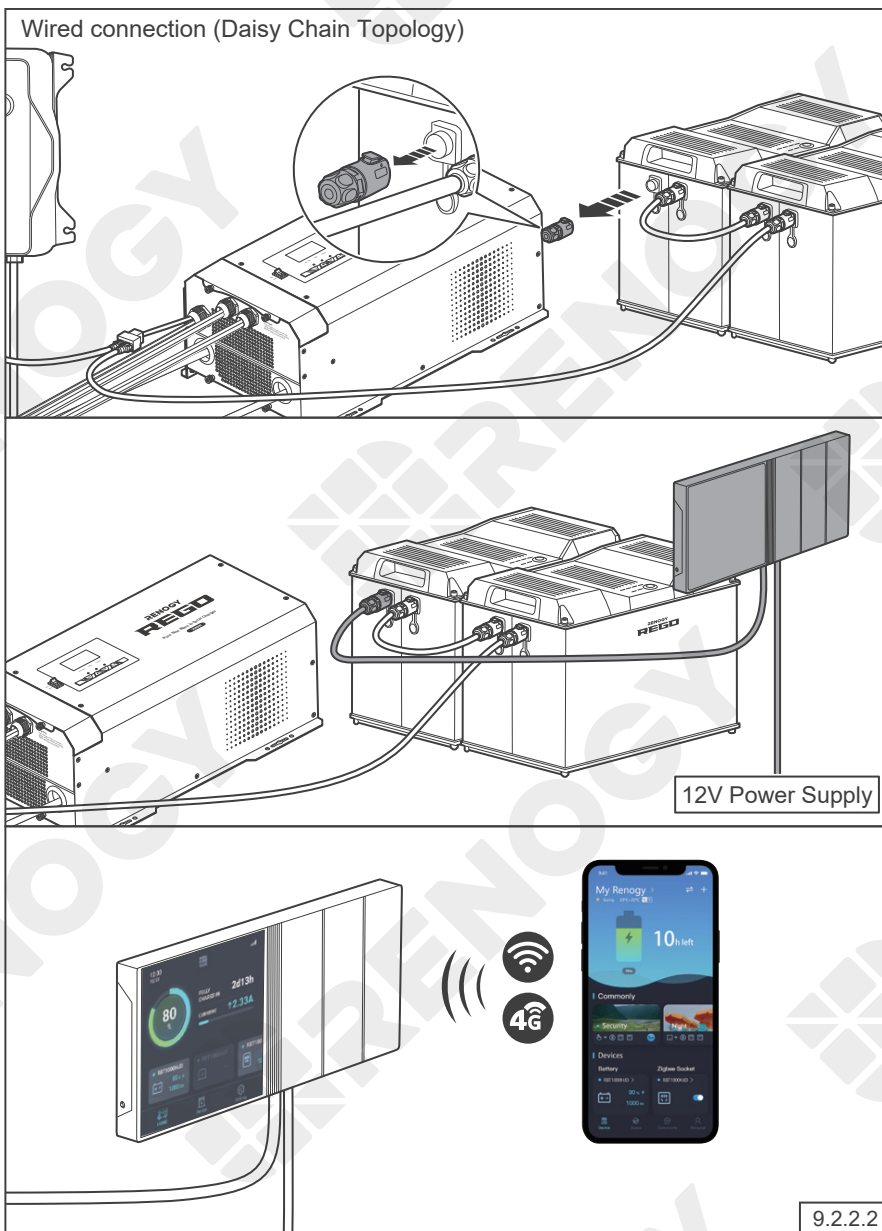

If the inter-device communication is established with the backbone topology, connect the Renogy ONE to the RV-C bus. Contact the RV manufacturer for more details before connection.

If the inter-device communication is established with the daisy chain topology, remove the Terminator Plug from the REGO device at either end of the daisy chain and connect the Renogy ONE to the free CAN Communication Port on the REGO device with the Communication Adapter Cable (sold separately).

Connect Renogy ONE to the DC Home app through Wi-Fi. Monitor and program the complete system on the Renogy ONE or the DC Home app.



# Putting Plates Back

After wiring, please reinstall the plates into the inverter charger.

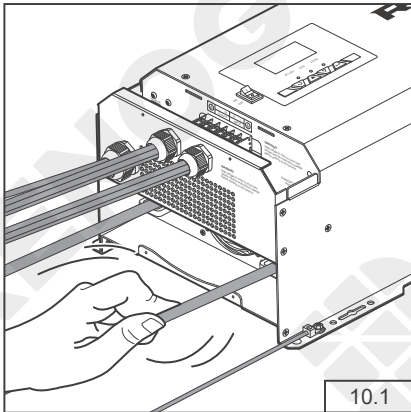

Check and make sure all cable connections are tight and secure.

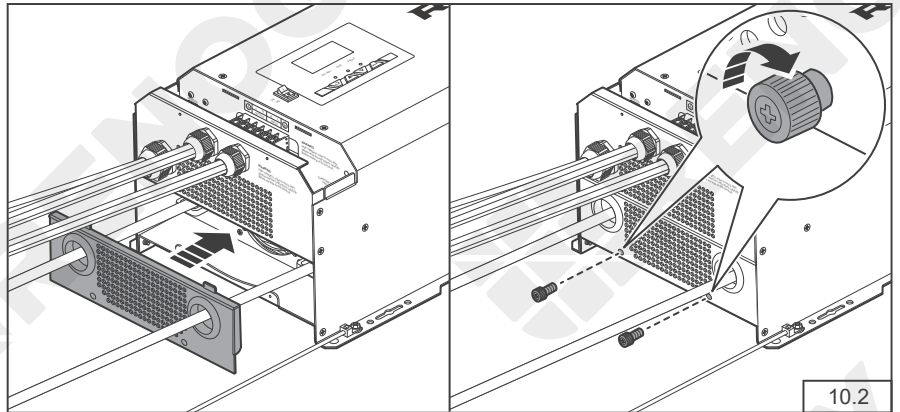

Install the DC Cable Plate and tighten the two panel screws clockwise to fix the plate.

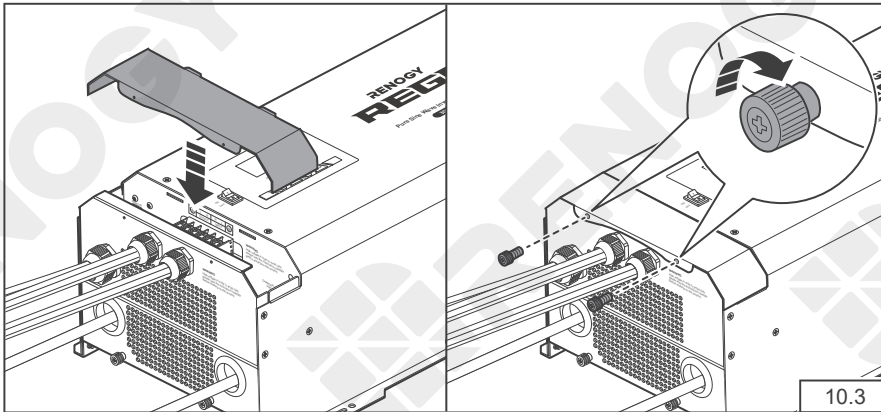

Install Top Plate. Tighten the two panel screws clockwise to fix the plate.



# Power on

Main Switch

Wired Remote Control

After installation, please power on the battery and AC input connected to the inverter charger, then turn on the inverter charger. REGO 12V 3000W Inverter Charger can be powered on via the main switch or wired remote control.



- Before the inverter charger is powered on, ensure that the load is turned off; otherwise the inverter charger may be overloaded.
- After the inverter charger is turned on, it will enter the self-test mode. The buzzer will sound for 7 seconds and the fan will turn automatically at the same time. The self-test takes about one minute.  
After the self-test, the sound disappears, and the fan stops running.

## Main Switch

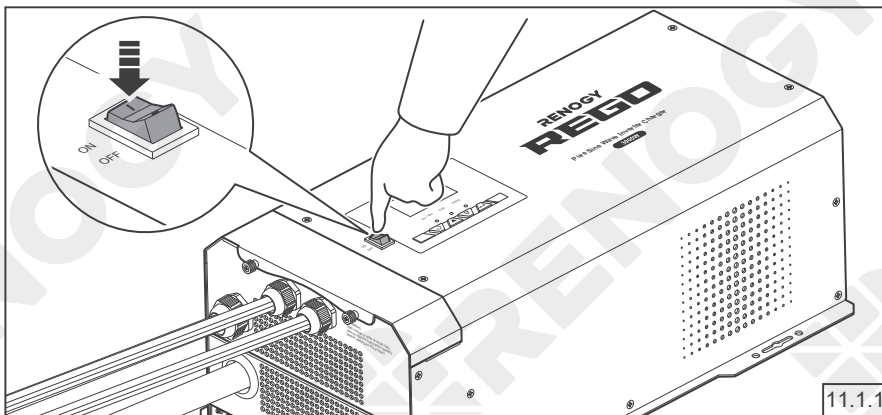

Press the main switch of the inverter charger to the "ON" position to power the inverter charger on.

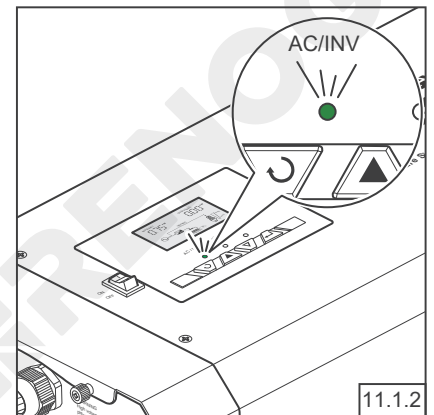

The screen lights up and displays the status after the inverter charger is powered on. The indicator will light up based on the usage.

After the inverter charger is properly installed and powered on, if any of the following conditions is not met, it means the inverter charger needs troubleshooting.

- The buzzer rings for 7 seconds;
- The fan operates with the sound;
- The screen lights up;
- The indicator lights up.

Please contact us through [renogy.com/contact-us/](https://renogy.com/contact-us/).





# Power on

Main Switch

Wired Remote Control

## Wired Remote Control

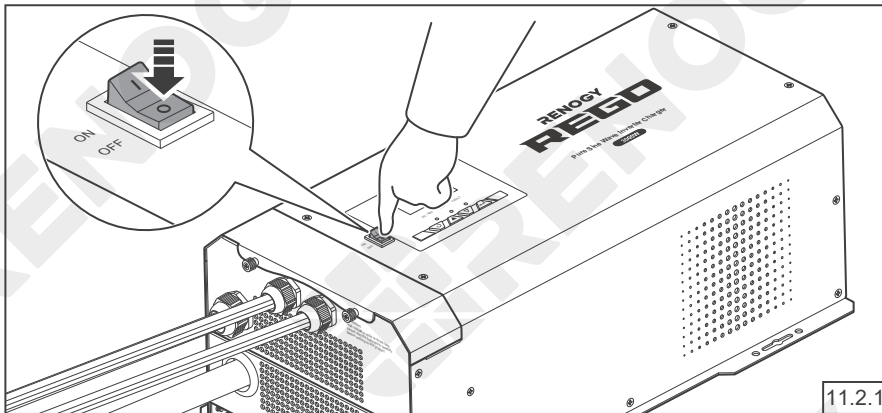

If you use the wired remote control, please turn the main switch of the inverter charger to "OFF" first.

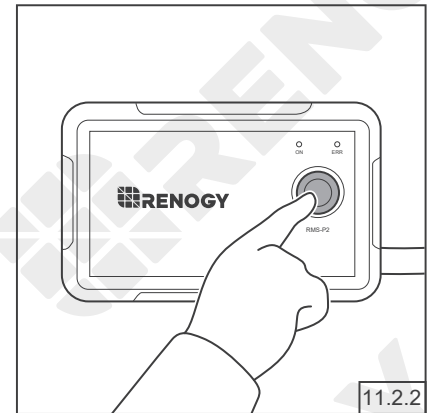

Press the button on the wired remote control.

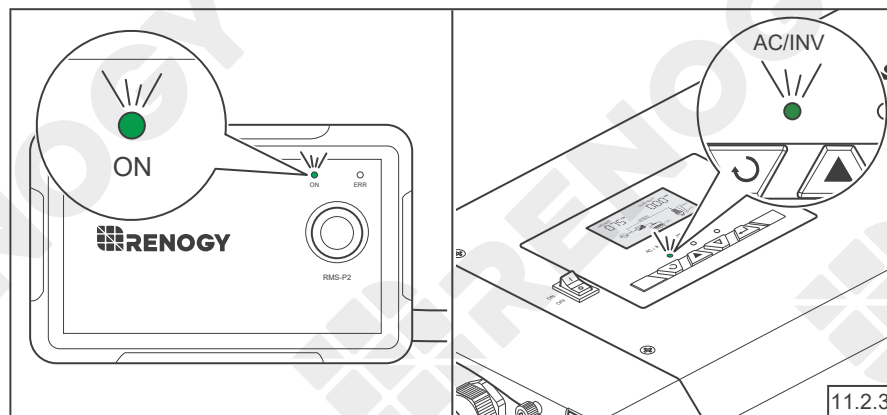

After the inverter charger is powered on, the wired remote control indicator and the inverter charger indicator will light up based on the usage. The inverter charger screen lights up and displays the operating status.

After the inverter charger is properly installed and powered on, if any of the following conditions is not met, it means the inverter charger needs troubleshooting.

- The buzzer rings for 7 seconds;
- The fan operates with the sound;
- The screen lights up;
- The indicator lights up;
- The ON indicator of the wired remote control lights up.

Please contact us through [renogy.com/contact-us/](https://renogy.com/contact-us/).



# Operation

LCD Setting Battery Type

## LCD

You can view the current operating status and warning messages of the inverter charger on the screen. With the 4 buttons, you can turn the display pages or set parameters of the inverter charger. For more details, please visit [renogy.com](http://renogy.com) for the user manual.

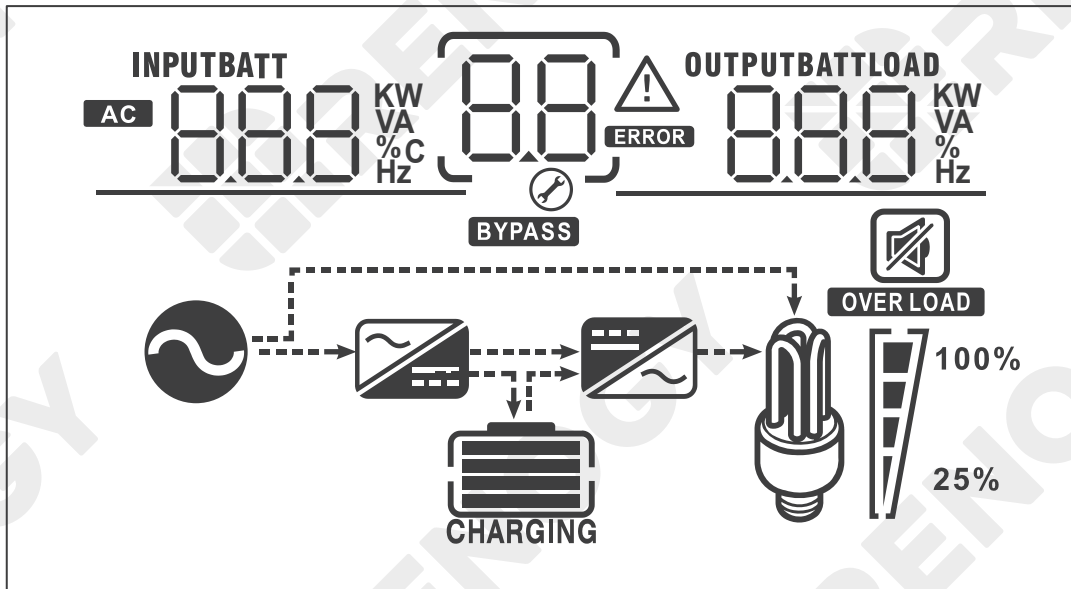













Icon	Function Description
<b>Input Source Information</b>	
<b>AC</b>	Indicates the AC input.
INPUTBATT 888 KW VA %C Hz	Indicates input voltage, input frequency, battery voltage and charger current.
<b>Configuration Program and Fault Information</b>	
88	Indicates setting programs.
	Indicates the warning and fault codes. Warning:  flashing with warning code.
	Fault:  lighting with fault code.
<b>Output Information</b>	
OUTPUTBATTLOAD 888 KW VA % Hz	Indicates output voltage, output frequency, load percent, load in VA, load in Watt and discharging current.



# Operation

LCD

Setting Battery Type

Icon	Function Description	
<b>Battery Information</b>		
 CHARGING	Indicates battery level by 0-24%, 25-49%, 50-74% and 75-100% in battery mode and charging status in line mode.	
In AC mode, it will present battery charging status.		
Status	Battery Voltage	LCD Display
Constant Current mode / Constant Voltage mode	<12.0V	4 bars will flash in turn.
	12.0V - 12.5V	Bottom bar will be on and the other three bars will flash in turn.
	12.5V - 13.0V	Bottom two bars will be on and the other two bars will flash in turn.
	13.0V	Bottom three bars will be on and the top bar will flash.
Floating mode. Batteries are fully charged.		4 bars will be on.
In battery mode, it will present battery capacity.		
Load Percentage	Battery Voltage	LCD Display
Load >50%	<10.3V	
	10.3V - 10.8V	
	10.8V - 11.3V	
	>11.3V	
50%>Load>20%	<10.9V	
	10.9V - 11.4V	
	11.4V - 11.9V	
	>11.9V	
Load <20%	<11.2V	
	11.2V - 11.7V	
	11.7V - 12.2V	
	>12.2V	











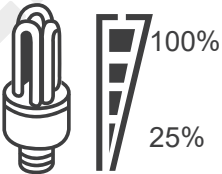

# Operation

LCD

Setting Battery Type

Icon	Function Description			
<b>Load Information</b>				
<b>OVER LOAD</b>	Indicates overload.			
	Indicates the load level by 0-24%, 25-49%, 50-74% and 75-100%.			
	0-24%	25-49%	50-74%	75-100%
				
<b>Mode Operation Information</b>				
	Indicates the inverter charger is connected to the shore power.			
<b>BYPASS</b>	Indicates the load is supplied by the utility power.			
	Indicates the utility charger circuit is working.			
	Indicates the DC/AC inverter circuit is working.			
<b>Mute Operation</b>				
	Indicates the alarm of the inverter charger is disabled.			



# Operation

LCD

Setting Battery Type

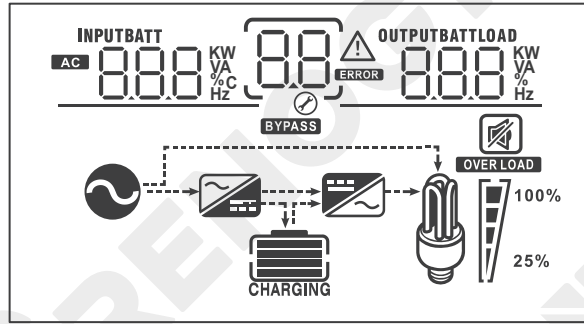

AC/INV

CHG

FAULT



	Exit the settings and go back to the menu.
	Menu key.
	Menu key.
	<ol style="list-style-type: none"> <li>1. Press and hold the button to enter the parameter setting menu.</li> <li>2. Press to change/confirm setting in the parameter setting menu.</li> </ol>



# Operation

LCD

Setting Battery Type

## Setting Battery Type

Set the battery type immediately after the inverter charger is powered on. Refer to the specifications provided by the battery manufacturer when choosing a preset battery. Damage caused by incorrect battery type voids warranty.

Battery types supported by the inverter charger: AGM / GEL / SEALED LEAD ACID / OPEN LEAD ACID FLOODED / CALCIUM / DE-SULPHATION / LI.

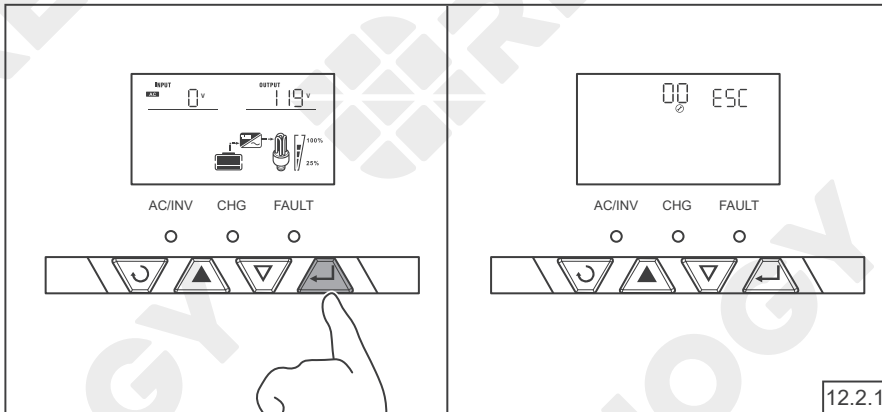

12.2.1

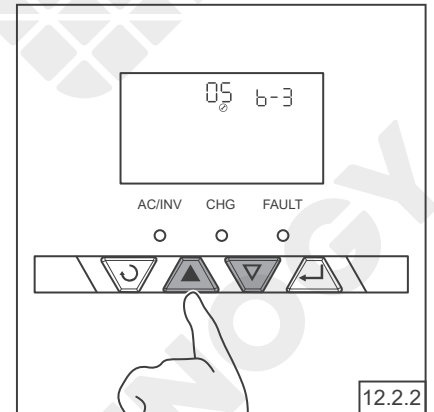

12.2.2

Long press until the screen enters settings.

Press or to program [05].

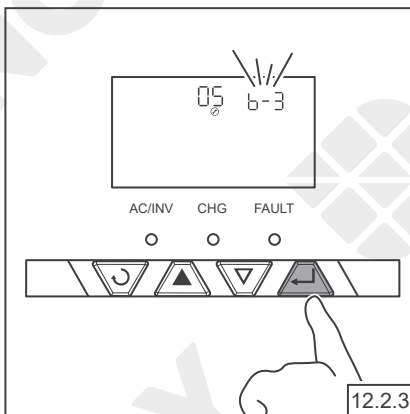

12.2.3

Press to enter [05] settings.

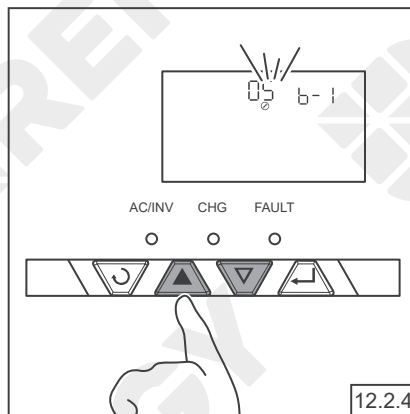

12.2.4

Press or and select the battery type on demand and by referring to the following table.

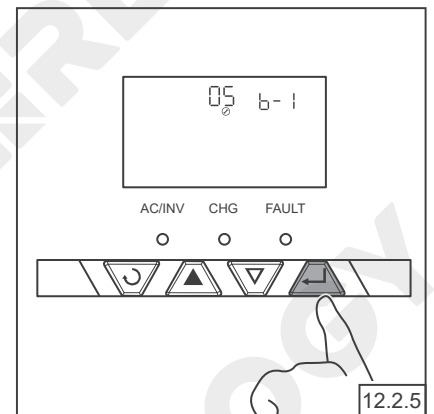

12.2.5

After selection, Press to save settings.



# Operation

LCD

Setting Battery Type

Program Number	Description	Parameter Setting	Boost Voltage	Float Voltage
05	For accurate charging, connection to a temperature sensor is required.	Type of battery		
		Gel 1	14.0V	13.7V
		A.G.M.1	14.1V	13.4V
		A.G.M.2	14.6V	13.7V
		Sealed Lead Acid	14.4V	13.6V
		Gel 2	14.4V	13.8V
		Open Lead Acid / Flooded	14.8V	13.8V
		Calcium	15.1V	13.6V
		De-sulphation	15.5 for 4 hrs	
		Li	When the voltage reaches 14.7V, the charging will stop. When the voltage drops below 12.9V, the charging will resume.	



- The voltage of lithium charging is preset to 14.7V. When the charging voltage reaches the preset threshold 14.7V, the inverter charger stops charging. It resumes charging when the charging voltage drops below 12.9V.
- If the preset battery parameters are not compatible with your system, you can set the battery type to b-0 to enter the custom mode. You can also use the DC Home app to customize the parameters. For details, please visit [renogy.com](http://renogy.com) to view the user manual.

# Working

REGO 12V 3000W Inverter Charger combines an inverter charger with an automatic transfer switch into one complete system. Featuring a 3-stage battery charging mode when connected to the utility AC power, the inverter charger can meet powerful needs as well as charge your battery bank. As a power supply, it is capable of producing cleaner, smoother, and more reliable electricity to address your diverse needs.

The inverter charger is equipped with a 30A transfer relay switch that switches between the charging and the standby mode depending on availability of AC input power. If AC is present, the transfer relay bypasses up to 30A of the incoming AC power through the inverter to power the AC loads on the inverter's output. Simultaneously, the inverter charges the battery up to 75 Amps. In the event that AC inverter charger gets disconnected, and the inverter will power the loads through the battery bank.

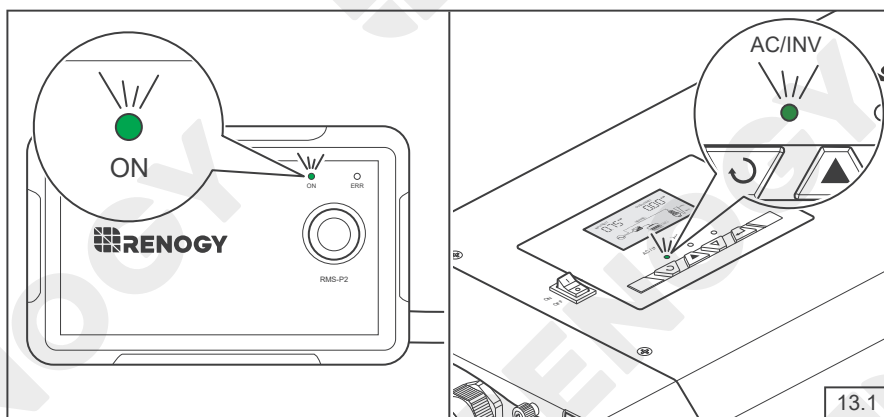

The ON indicator of the wired remote control and the AC/INV indicator of the inverter charger flash green when the inverter charger is powering loads from the battery.

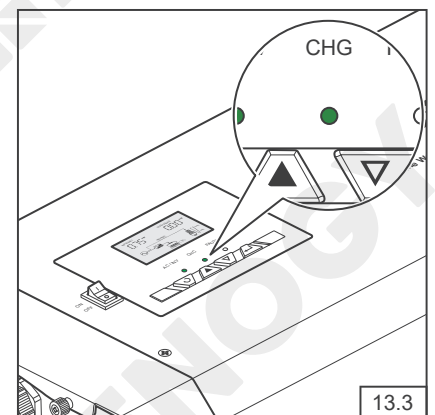
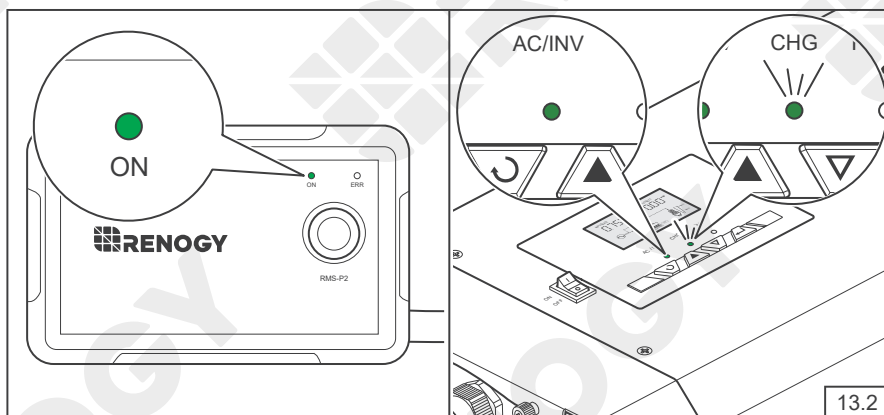

The ON indicator of the wired remote control and the AC/INV indicator of the inverter charger are solid green when the inverter charger is powering the loads through an AC Input Source, and when the inverter charger starts to charge the battery at the same time. The CHG indicator flashes green.

When the battery is fully charged, the CHG indicator is solid green.



- If the AC/INV indicator and CHG indicator do not light up as described in this guide, but the power supply equipment (batteries and AC input source) is operating normally, the inverter charger needs troubleshooting. Please contact our customer service through [renogy.com/contact-us/](https://renogy.com/contact-us/).
- You can set the charging current with program [11]. If the default settings do not apply to your installation, you can set them in the custom (battery) settings (as recommended by the battery manufacturer), or via the DC Home app. For more details, please visit the [renogy.com](https://renogy.com) for the user manual.

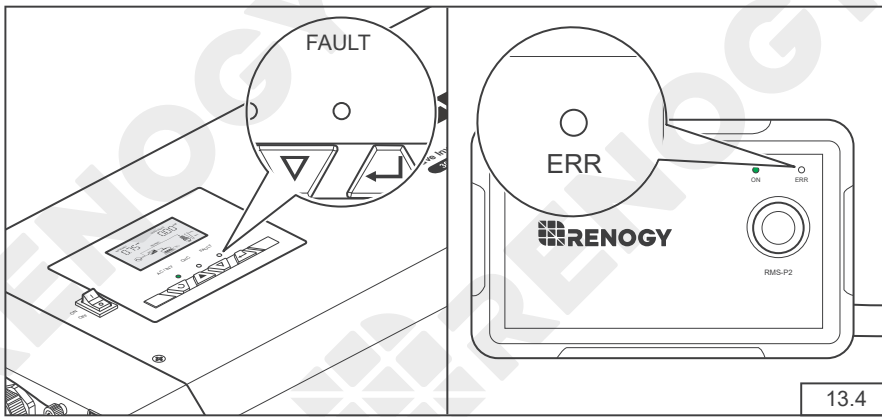

Under normal conditions, the inverter charger FAULT indicator and the wired remote control ERR indicator will not light up.

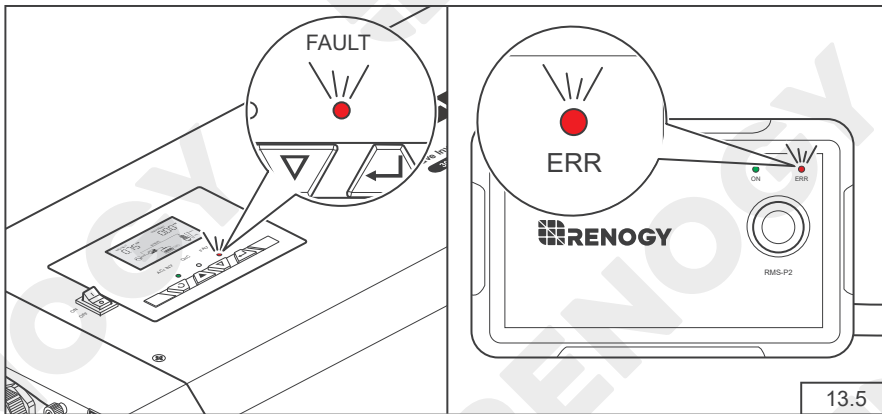

If the FAULT indicator of the inverter charger and the wired remote control ERR indicator flash red, and the buzzer sounds at the same time (0.5s), it means warnings are provided by the inverter charger. Please visit [renogy.com](http://renogy.com) for the user manual to investigate it.

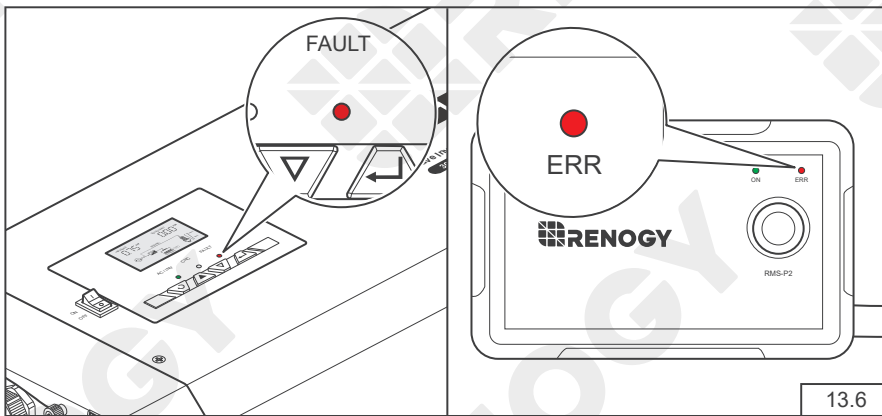

If the FAULT indicator of the inverter charger and the wired remote control ERR indicator is always in red, and the buzzer sounds long, it means that the inverter charger needs troubleshooting. Please seek help through [renogy.com/contact-us/](http://renogy.com/contact-us/).





# Power Off

Main Switch

Wired Remote Control

## Main Switch

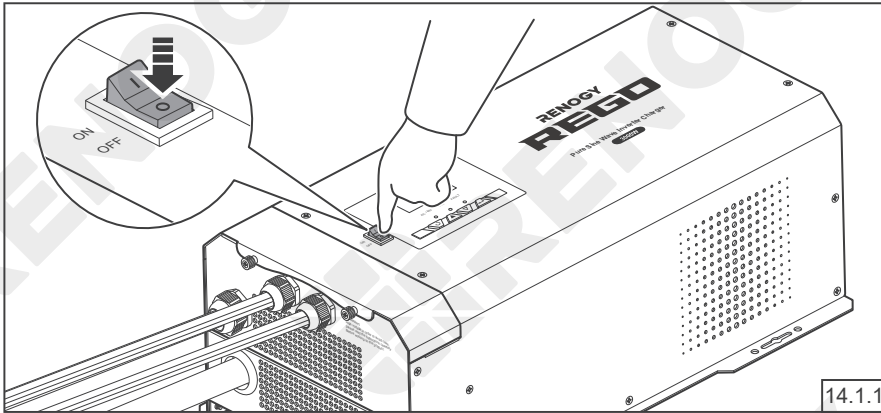

Press the main switch of the inverter charger to "OFF" to turn it off.

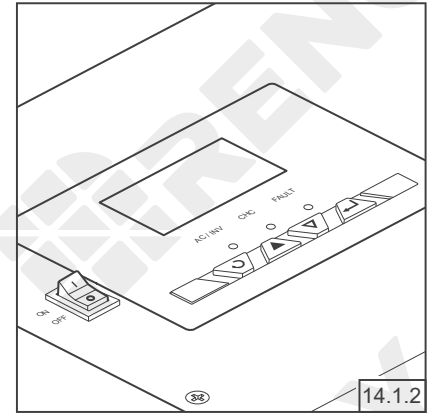

The screen and indicator lights turn off when the inverter charger is powered off.

## Wired Remote Control

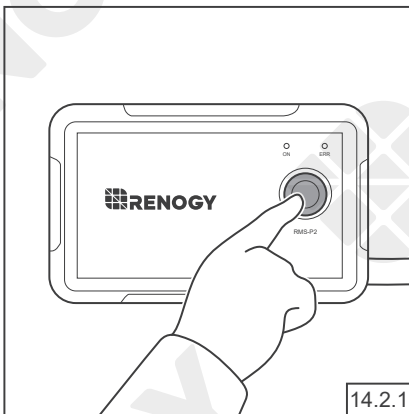

When using a wired remote control, press the button on the wired remote control to turn off the power.

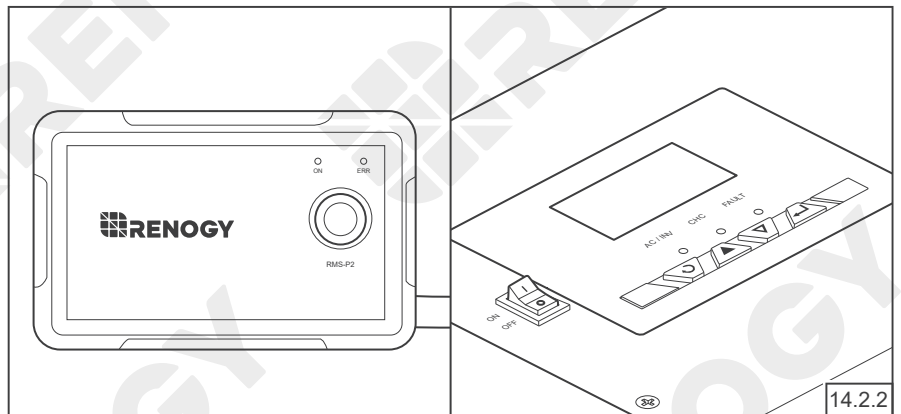

The ON indicator of the wired remote control, the screen, and indicator lights go off when the inverter charger is powered off.



# Overcurrent Protection

The inverter charger is integrated with two circuit breakers which ensure that the inverter charger keeps operating even when the input/output stops working. When the input/output circuit breaker is activated, a manual reset is required to resume operation.



- Risk of electric shock! Turn off the inverter charger and the power devices connected to it when the circuit breaker is reset.
- Please wear proper protective equipment and use insulated tools during operation. Be careful when touching bare terminals of capacitors as they may retain high lethal voltages even after power is removed.
- After resetting, please install the Top Plate back to the inverter charger.

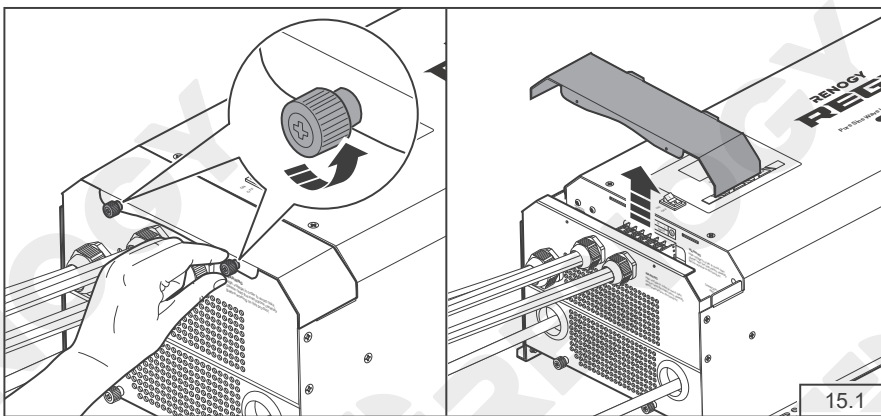

Turn the two upper panel screws counterclockwise by hand or a Phillips screwdriver, and remove the Top Plate.

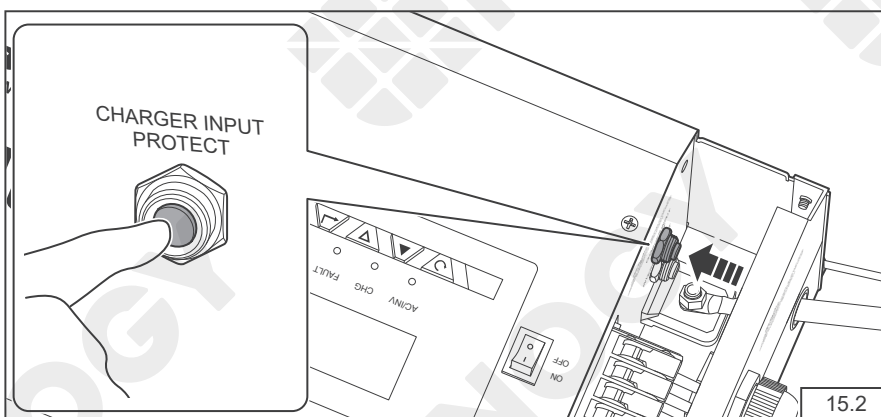

When the AC input current exceeds 40A, the Input Circuit Breaker will automatically pop out. Press to reset it.

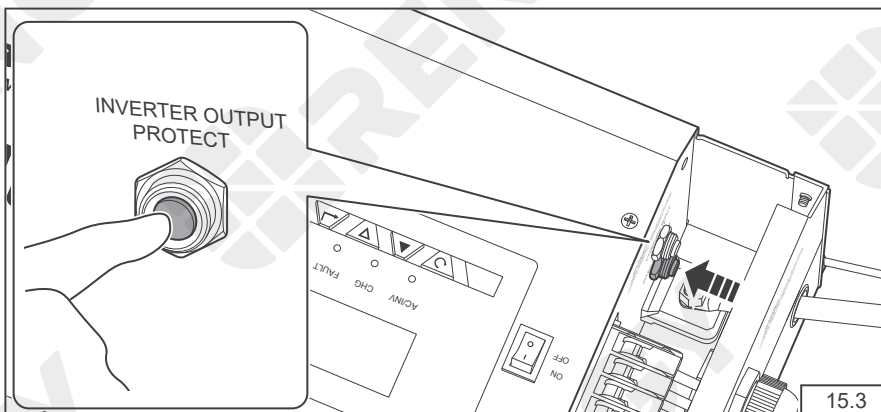

When the AC output current exceeds 30A, the Output Circuit Breaker will automatically pop out. Press to reset it.



# Maintenance

For optimum performance, it is recommended to perform these tasks irregularly.

- Ensure the inverter charger is installed in a clean, dry and ventilated area.
- Ensure there is no damage or wear on the cables.
- Ensure the firmness of the connectors and check if there are any loose, damaged or burnt connections.
- Make sure the AC / INV indicator, CHG indicator and FAULT indicator are in proper condition.
- Ensure there is no corrosion, insulation damage, or discoloration marks of overheating or burning.
- If the inverter charger is dirty, use a damp cloth to clean the outside of the device to prevent dust and dirt from accumulating. Before the inverter charger is powered on, please make sure it is completely dry after cleaning.
- Make sure the ventilation holes are not blocked.



- Risk of electric shock! Make sure that all power supplies are turned off before touching terminals on the inverter charger. Please wear proper protective equipment and use insulated tools during operation. Be careful when touching bare terminals of capacitors as they may retain high lethal voltages even after power is removed.

## FCC Statement

This device complies with Part 15 of the FCC Rules. Operation is subject to the following two conditions:

- (1) This device may not cause harmful interference.
- (2) This device must accept any interference received, including interference that may cause undesired operation.

This equipment has been tested and found to comply with the limits for a Class B digital device, pursuant to Part 15 of the FCC Rules. These limits are designed to provide reasonable protection against harmful interference in a residential installation. This equipment generates, uses and can radiate radio frequency energy and, if not installed and used in accordance with the instructions, may cause harmful interference to radio communications. However, there is no guarantee that interference will not occur in a particular installation. If this equipment does cause harmful interference to radio or television reception, which can be determined by turning the equipment off and on, the user is encouraged to try to correct the interference by one or more of the following measures:

- (1) Orient or relocate the receiving antenna.
- (2) Increase the separation between the equipment and receiver.
- (3) Connect the equipment into an outlet on a circuit different from that to which the receiver is connected.
- (4) Consult the dealer or an experienced radio/TV technician for help.

## FCC Radiation Exposure Statement

This equipment complies with FCC radiation exposure limits set forth for an uncontrolled environment. This equipment should be installed and operated with minimum distance 20 cm between the radiator & your body.



## Renogy Empowered

Renogy aims to empower people around the world through education and distribution of DIY-friendly renewable energy solutions.

We intend to be a driving force for sustainable living and energy independence.

In support of this effort, our range of solar products makes it possible for you to minimize your carbon footprint by reducing the need for grid power.



## Live Sustainably with Renogy

Did you know? In a given month, a 1KW solar energy system will...



Save 170 pounds of coal from being burned



Save 300 pounds of CO<sub>2</sub> from being released into the atmosphere



Save 105 gallons of water from being consumed



## Renogy Power **PLUS**

Renogy Power Plus allows you to stay in the loop with upcoming solar energy innovations, share your experiences with your solar energy journey, and connect with like-minded people who are changing the world in the Renogy Power Plus community.

Also, follow us on Youtube @Renogy Solar, Facebook @Renogy, and Instagram @renogyofficial.

Visit [renogy.com](https://renogy.com) to find relevant documentation or get more support via "[Contact Us](#)".  
Renogy reserves the right to change the contents of this manual without notice.

Join the Renogy Power Plus Community  
by downloading the DC Home App.  
Find your e-warranty here, and more.

