

Renogy ONE

M1

VERSION A1

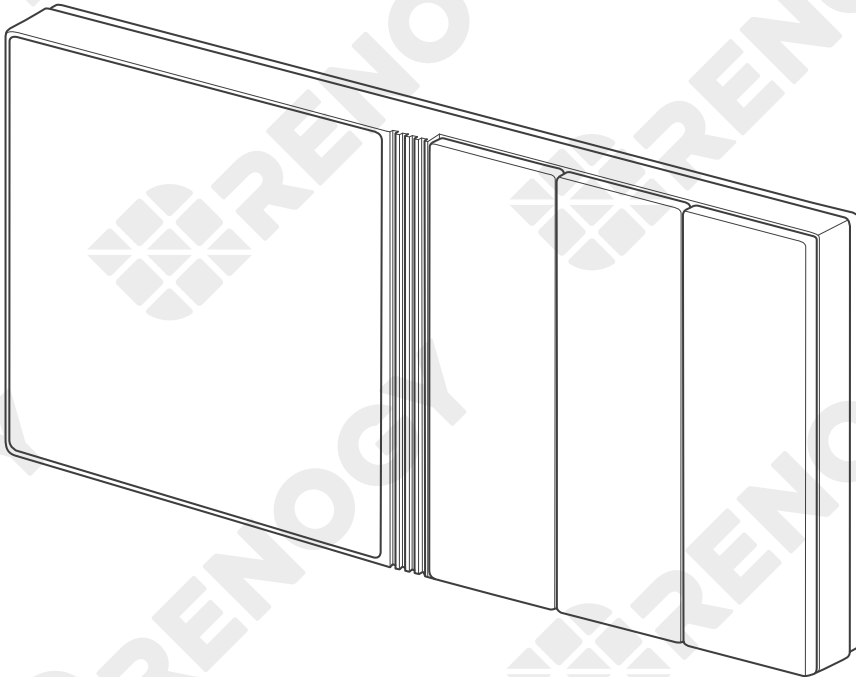

QUICK GUIDE



This Quick Guide contains important installation, operation, and maintenance instructions for Renogy ONE M1, hereinafter referred to as “Renogy ONE”. Please read the Quick Guide carefully before using the device.

For additional support, contact our customer service through [renogy.com/contact-us/](https://www.renogy.com/contact-us/).



Renogy offers premium services worldwide:

North America	US	www.renogy.com	CA	ca.renogy.com
	AU	au.renogy.com	CN	www.renogy.cn
Asia/Pacific	JP	renogy.jp	KR	kr.renogy.com
	UK	uk.renogy.com	DE	de.renogy.com
Europe	FR	fr.renogy.com	ES	es.renogy.com



Scan the QR code to install the DC Home app.



For detailed instructions, scan the QR code for the User Manual.

Table of Contents

Package Contents	01
Product Overview	02
Wiring Diagram.....	04
Communication Diagram.....	05
Renogy ONE Communication Architecture	05
Energy Device Communication Connections	05
Preparation	07
Required Tools	07
Mounting Location	10
Power Wiring	12
Communication Wiring (Optional).....	14
Load Wiring (Optional).....	16
Mounting.....	20
Operation.....	21
Activation.....	21
WLAN	21
Pairing with App.....	21
Add Devices	22
Power On/Off.....	22
Control External Loads.....	23
Maintenance.....	24



Package Contents

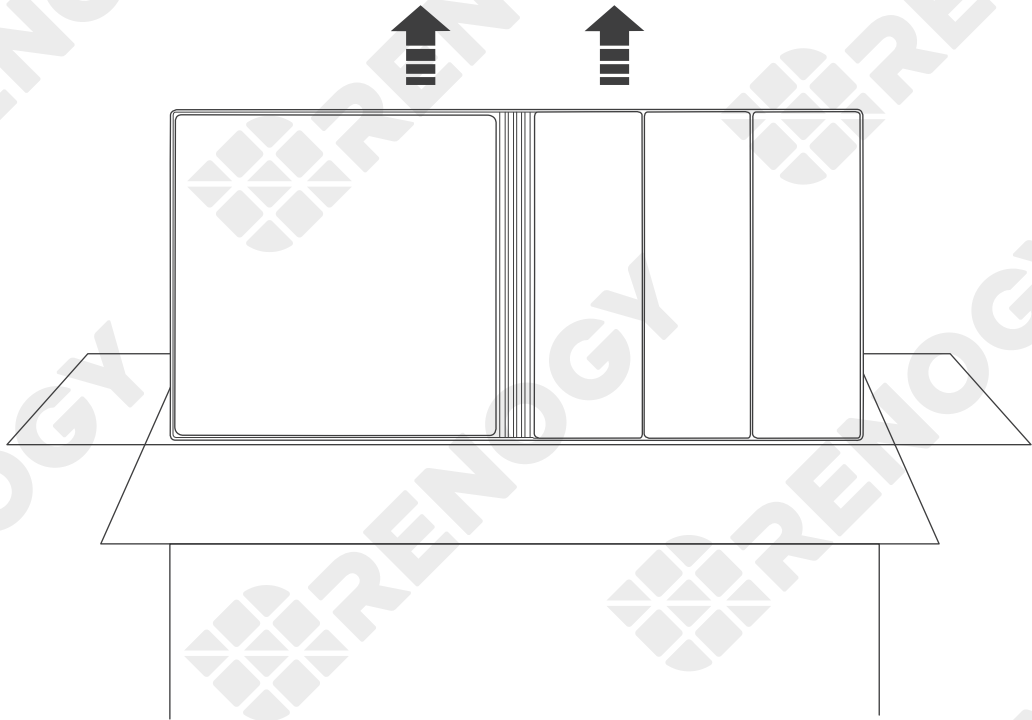

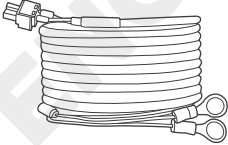
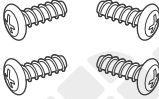
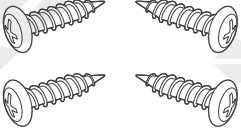
Quick Guide × 1	12V Power Cable (5m) × 1	M2 Screws × 4	M4 Mounting Screws × 4
		ST2 x 1.2 x 6.5 mm 	ST4 x 2 x 13 mm 

Product Overview

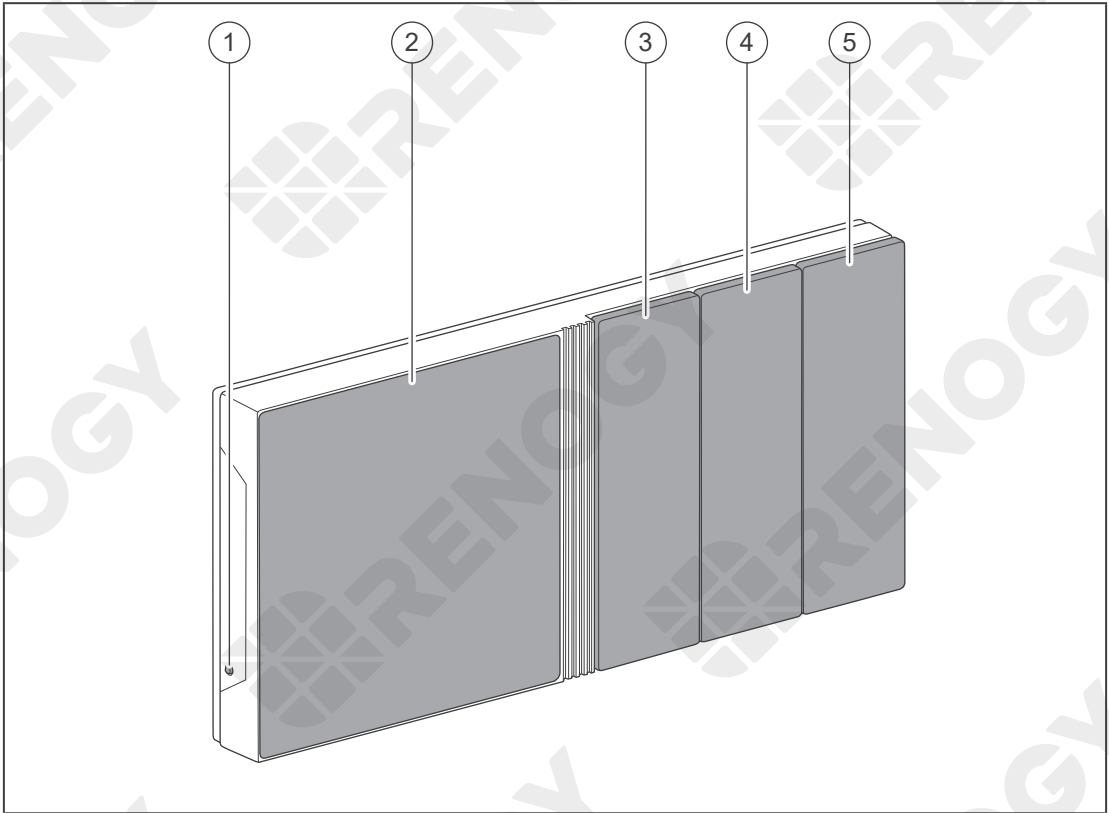

No.	Part	No.	Part
1	Power Button	4	Panel Switch 2
2	Touch Screen	5	Panel Switch 3
3	Panel Switch 1		

Product Overview

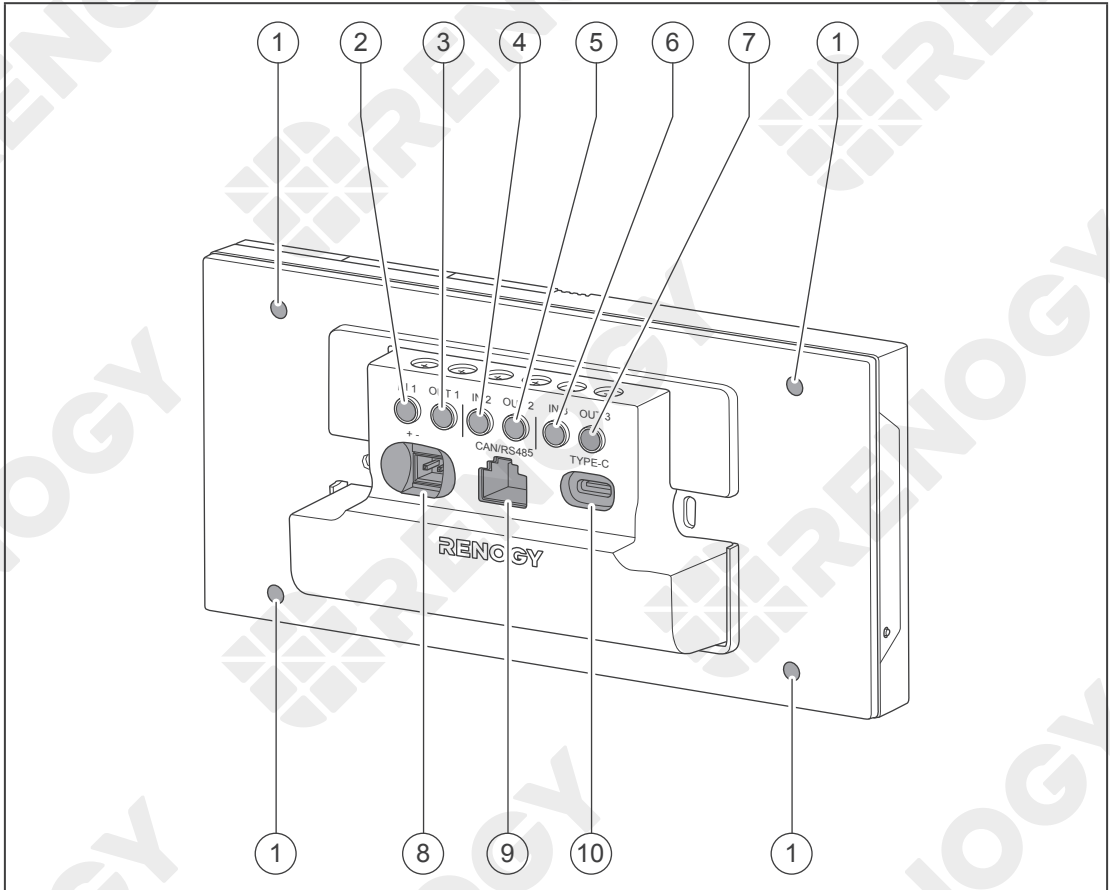

No.	Part	No.	Part
1	Mounting Holes	6	IN 3 (External Load Input Terminal)
2	IN 1 (External Load Input Terminal)	7	OUT 3 (External Load Output Terminal)
3	OUT 1 (External Load Output Terminal)	8	Power Port (12V, 3.5W)
4	IN 2 (External Load Input Terminal)	9	RJ45 Port
5	OUT 2 (External Load Output Terminal)	10	Alternate Power Input Port (Type-C, 5V, 3.5W)



- Please inspect Renogy ONE for any visible damage including cracks, dents, deformation, and other visible abnormalities before installation.



Wiring Diagram

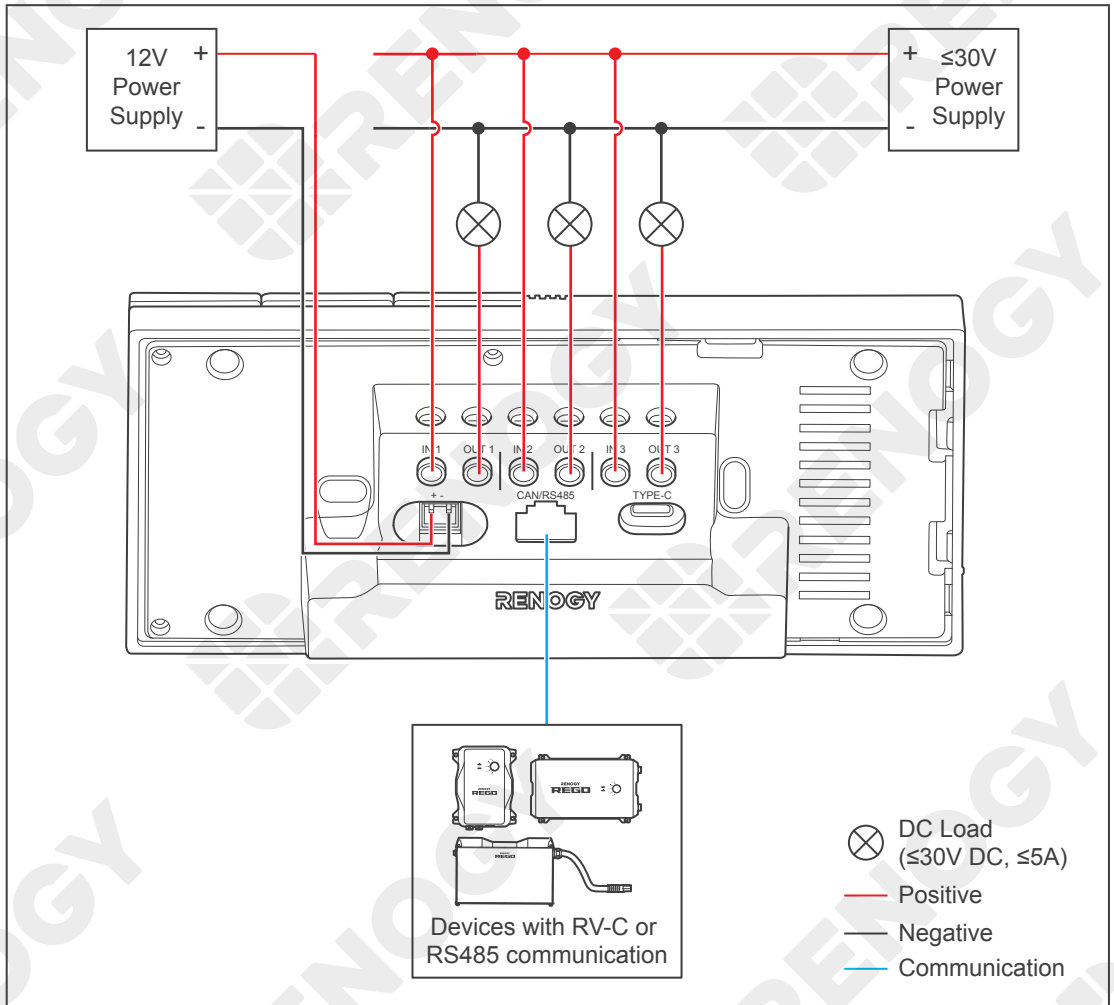

- Illustrations in the Quick Guide are for reference only.
- Renogy ONE is only suitable for safe use in areas below 2,000 meters above sea level.
- There are no user serviceable parts inside Renogy ONE. Do not disassemble or attempt to repair it.



Communication Diagram

Renogy ONE Communication Architecture

Energy Device Communication Connections

Renogy ONE Communication Architecture

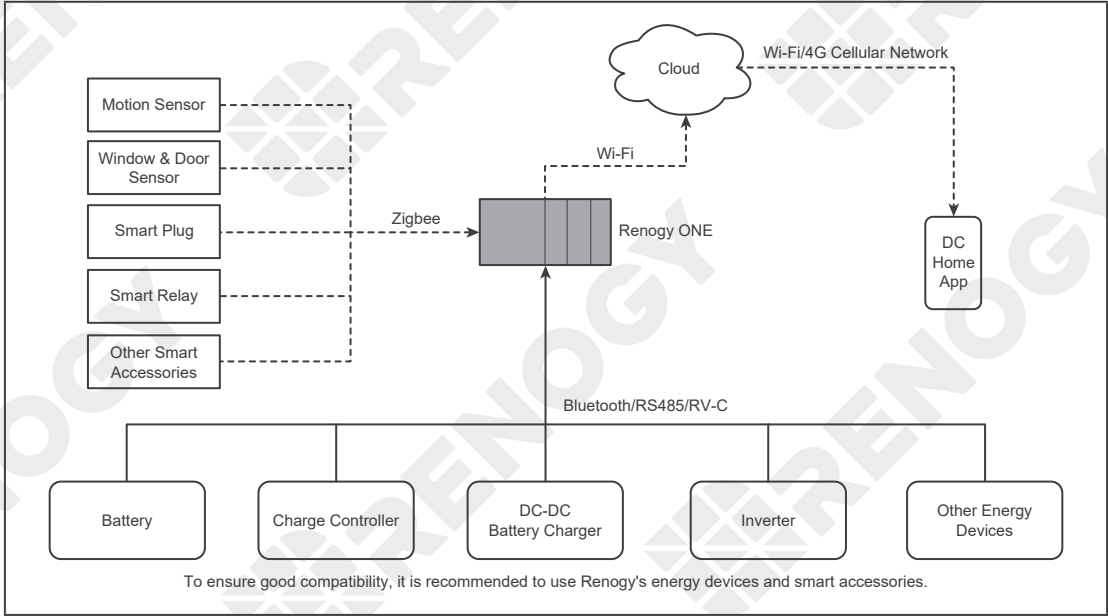

Energy Device Communication Connections

Bluetooth

1. For devices with a built-in Bluetooth module or an external Bluetooth module (Renogy BT-1 or BT-2):
2. For devices connected to Renogy Communication Hub and BT-2:

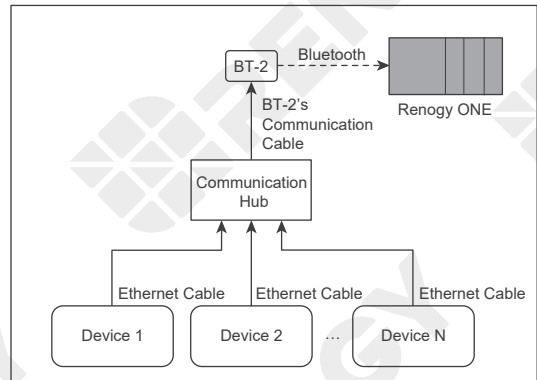
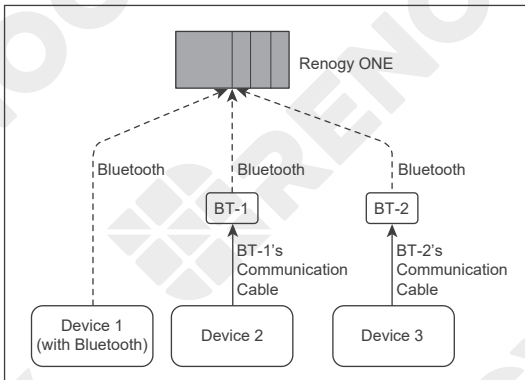



Communication Diagram

Renogy ONE Communication Architecture

Energy Device Communication Connections

RS485 Communication

1. For a single device with RJ45 port:

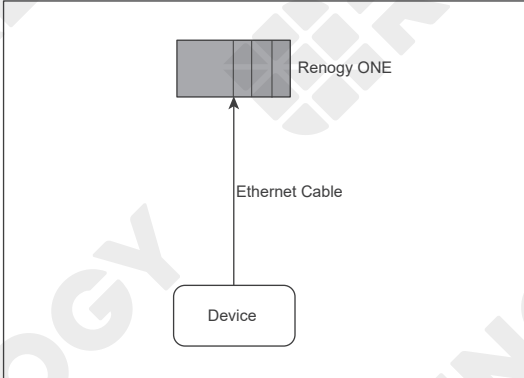

2. For devices connected to Renogy Communication Hub:

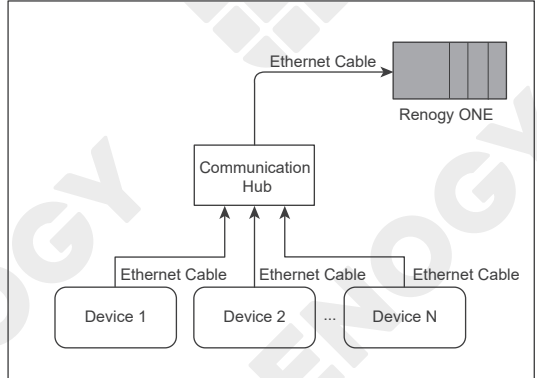

RV-C Communication

For REGO devices connected with RV-C daisy chain topology:

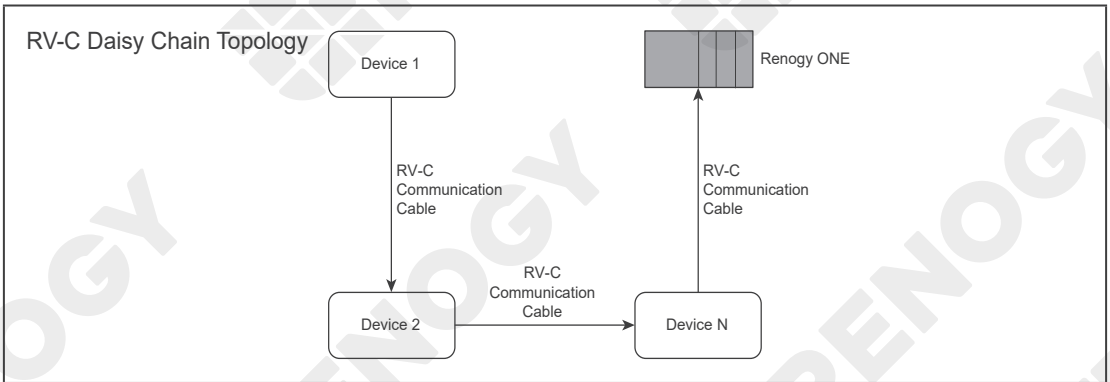

For backbone topology, please contact our customer service through renogy.com/contact-us/.



Preparation

Required Tools

Mounting Location

Required Tools



- To prevent rework, please follow the installation steps below one after another.

Required Tools

Phillips Screwdriver (#1) (for M2 Screws)	Phillips Screwdriver (#2) (for M4 Screws)	Insulation Tape
Skill Saw	Measuring Tape	Drill (1.5mm)

Mounting Template

Please tear off this piece of paper and paste it to the mounting location for drilling holes.

You can also use another piece of paper as the mounting template.

The installation hole comes in 110 mm × 65 mm (4.33 in × 2.56 in).







Preparation

Required Tools

Mounting Location

Mounting Location



- Install Renogy ONE on a vertical surface indoors protected from direct sunlight, high temperature, and water. Make sure there is good ventilation.
- Mounting Renogy ONE requires installation holes. Make sure that you can drill holes on the mounting position.
- To ensure quality wireless communication for Renogy ONE, keep it away from metal objects at a minimum distance of 200 mm or 7.9 inches.
- If the included 12V power cable is not long enough for connecting Renogy ONE to your DC power supply, re-select a mounting position or use an extension cable (≥ 22 AWG).
- Confirm the polarities of the included cable and the extension one before connecting them. A reverse polarity contact will result in abnormal operations. The extension cable should not exceed 10 meters (32.8 feet).
- Ensure that the base cover of Renogy ONE is firmly mounted to the wall to prevent it from falling off.

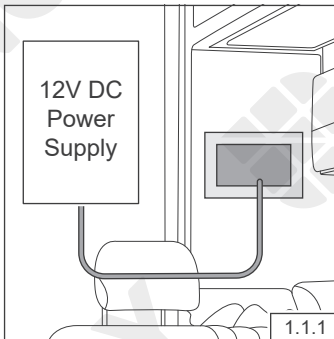

Tape the mounting template to the selected mounting location, and measure whether the 12V power cable is long enough to connect Renogy ONE to your DC power supply.

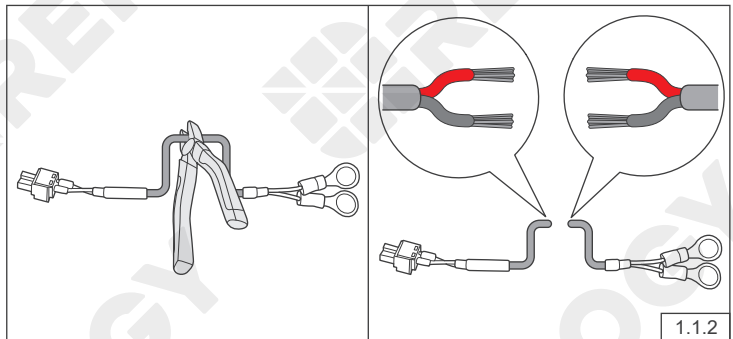

If the included 12V power cable is not long enough for connecting Renogy ONE to your DC power supply, re-select a mounting position or use an extension cable (≥ 22 AWG). If you do not need to extend the 12V power cable, go to Figure 1.1.4. Cut the included 12V power cable, and strip off some of the insulation.



Preparation

Required Tools

Mounting Location

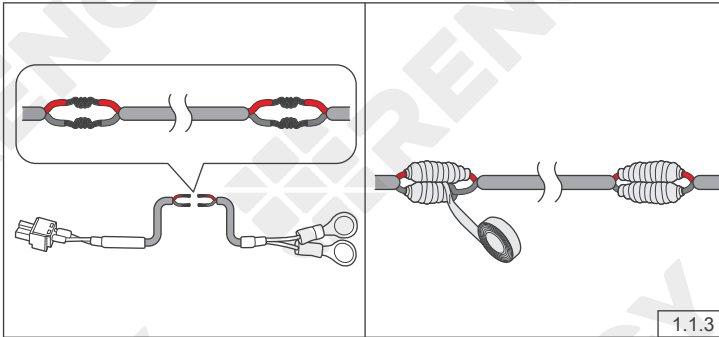

Strip some insulation off the extension cable, and connect the cable to the included 12V power supply cable. Tape over the cut-off areas.

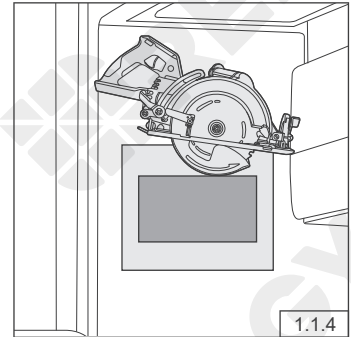

Use the drill and skill saw to dig the installation hole according to the gray mark on the mounting template.

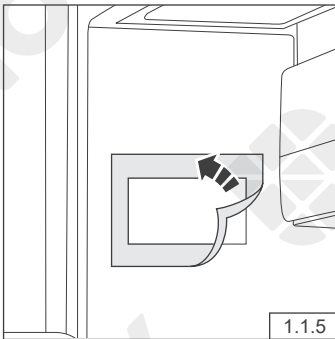

Tear off the mounting template.

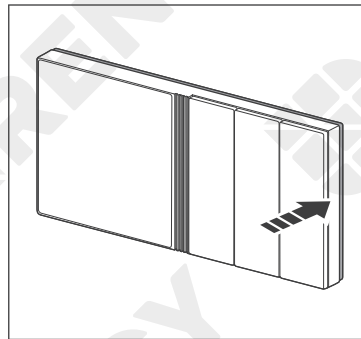

Remove the base cover of Renogy ONE with a Phillips screwdriver (#2).

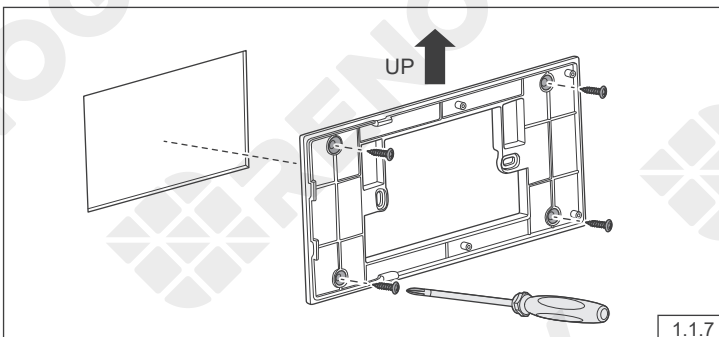
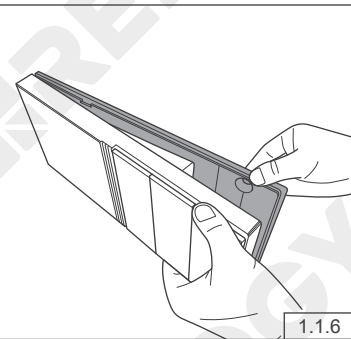

Put the protruding part of the base cover into the installation hole (in a direction and position as shown in Figure 1.1.7), and use a Phillips screwdriver to fasten the base cover with four M4 mounting screws through the mounting hole.

Note that screws are driven in straight into the mounting holes to ensure the base cover perfectly fits into Renogy ONE.



Power Wiring



- Renogy ONE can be connected to a DC power supply of up to 16V; otherwise Renogy ONE may be damaged.
- Illustrations in this quick guide are based on scenarios where REGO 12V 400Ah Lithium Iron Phosphate Battery and REGO 3 Ports 400A Battery Combiner Box are adopted as power supplies.
- Make sure the DC power supply is powered off before connection.
- Confirm the polarities of the DC power supply before connection. A reverse polarity contact will result in abnormal operations.
- After correct power cable connection and normal power-on of the DC power supply, Renogy ONE is automatically powered on. Failed automatic power-on indicates Renogy ONE needs troubleshooting. For details, refer to Troubleshooting in the user manual of Renogy ONE. For additional support, please contact our customer service through renogy.com/contact-us/.
- Risk of electric shock! Power off the DC power supply after the test on power-on of Renogy ONE is completed.

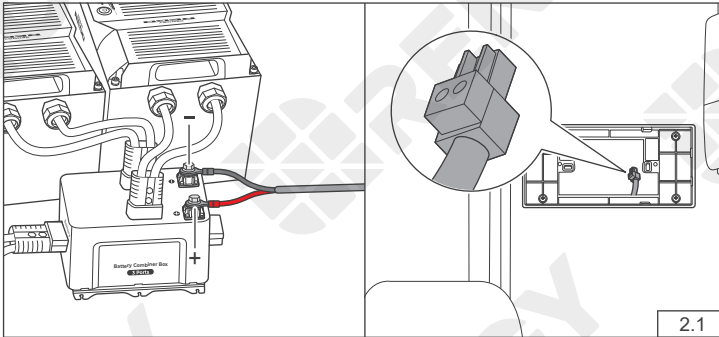

Connect the ring terminals of the 12V power cable to the positive and negative terminals of the DC power supply, and reserve the connector end of the power cable in the installation hole.

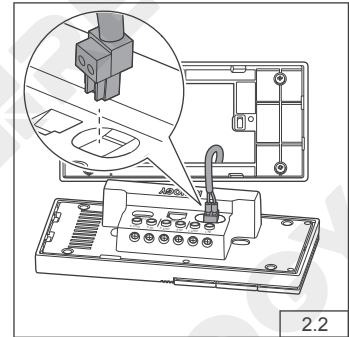

Insert the 12V power cable terminal block into Renogy ONE power port.



Power Wiring

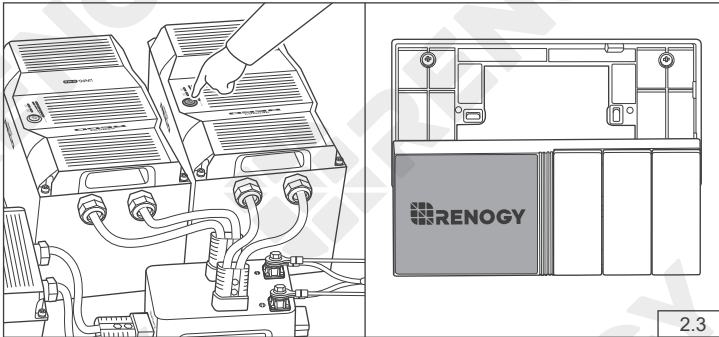

Power on the DC power supply and check if Renogy ONE automatically turns on with the LCD lighting up.



Communication Wiring (Optional)

Renogy ONE can communicate with Renogy energy devices in several ways:

1. Bluetooth wireless communication;
2. Wired communication based on RS485 protocol;
3. Wired communication based on RV-C protocol.

You can choose an appropriate communication method according to the actual situation.

- For Bluetooth wireless communication, communication wiring is not required.
- For RS485 or RV-C communication, you need to wire Renogy ONE with energy devices.

How to wire RV-C communication cables varies depending on the connection network topology. Both backbone and daisy chain topologies are supported.

Connect devices to Renogy ONE according to the wiring diagram provided by the RV manufacturer. For technical support from Renogy, please contact us through renogy.com/contact-us/.

For scenarios where the RVs are installed with RV-C buses and where relevant devices are connected in backbone topology, see the user manual of Renogy ONE for connection details. If an RV-C bus is not pre-installed in the RV, please follow the steps below.

Recommended Accessories

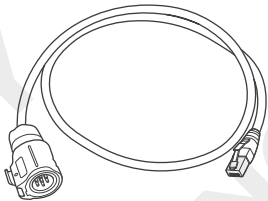
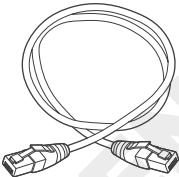
Communication Cable (LP16 Plug (7-Pin) to RJ45 Communication Adapter Cable) (for RV-C daisy chain topology connection)	Communication Cable (RJ45 Ethernet Cable) (for RS485 connection)
	



- Select the appropriate communication cable (sold separately) according to the distance between devices. The communication cable should be less than 6 meters (19.6 feet).
- For RV-C daisy chain topology, please make sure that the CAN communication socket of the first device is installed with a 120Ω LP16 terminal plug (7-pin).
- For detailed instructions, please refer to the User Manual at renogy.com or by scanning the QR code in the beginning part of the guide.



Communication Wiring (Optional)

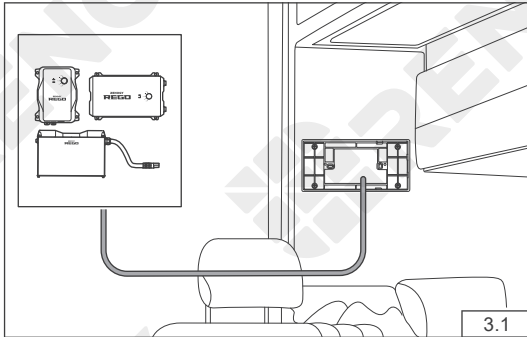

3.1

Ensure the selected communication cable is long enough to connect Renegy ONE to other devices.

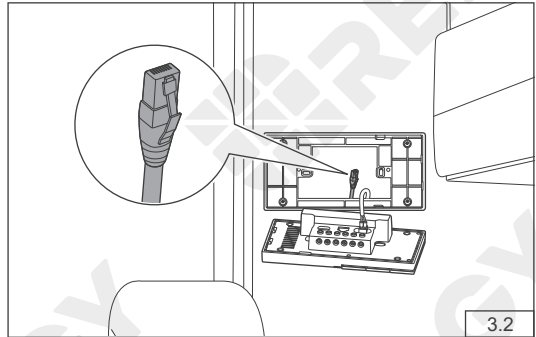

3.2

Pre-embed the RJ45 connector of the communication cable into the installation hole.

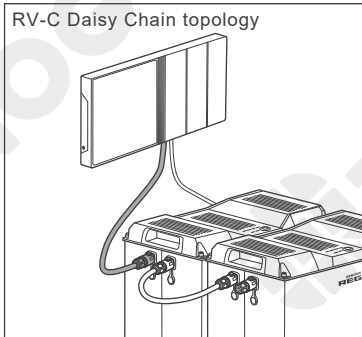

RV-C Daisy Chain topology

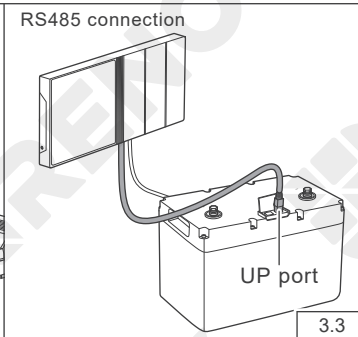

RS485 connection

3.3

If there is only one device, insert the other end of the communication cable to the communication port of the specific device in use.

If there are multiple devices, connect all the devices to Renegy Communication Hub. Follow the instructions in the user manual of Renegy ONE.

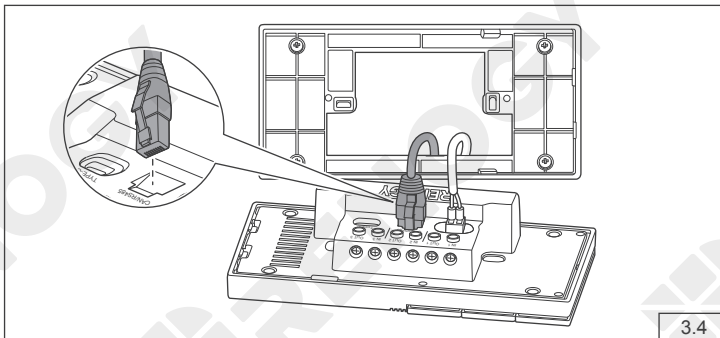

3.4

Connect the pre-embedded RJ45 connector to the RJ45 port of Renegy ONE.



Load Wiring (Optional)

Renogy ONE comes with 3 relays which can be connected to 3 DC loads (appliances) ($\leq 30V$ DC, $\leq 5A$). You can power on/off the loads via Panel Switches on Renogy ONE.

Recommended Accessories

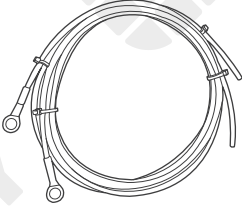
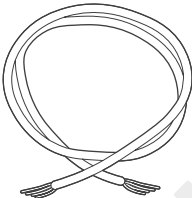
Ring Terminal to Bare Wire Tray Cable	Bare Wire
	



- For your safety, please refer to the user manual of Renogy ONE at renogy.com for the recommended wire gauge and length.
- Ensure that the working current of an external DC load is less than or equal to 5A; otherwise Renogy ONE may be damaged.
- Ensure that the output voltage of the DC power supply for an external DC load is less than or equal to 30V; otherwise Renogy ONE may be damaged.
- Make sure the DC power supply is powered off before connection.
- Confirm the polarities of the DC power supply and the load before connection. A reverse polarity contact will result in abnormalities.
- Make sure the DC power supply is powered off before wiring.
- Strip some insulation off the bare wire end according to the depth of the installation hole.
- The maximum screw torque of wire hatch is 0.4 N•m. Do not overtighten the screws to avoid damage to the hatch.



Load Wiring (Optional)

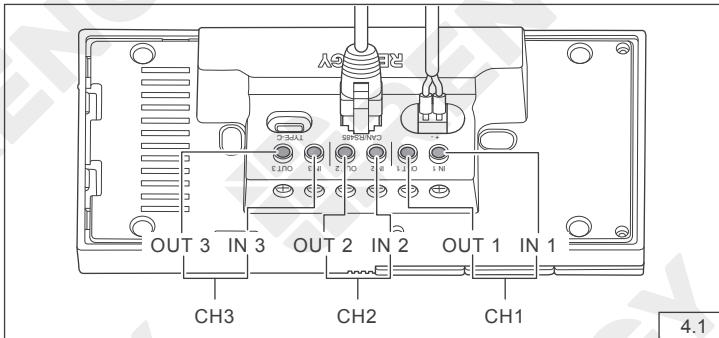

4.1

Ensure that the DC power supply cable and the cable that is connected to the positive pole of the load (appliance) are connected to the same group of terminals. For example, "IN 1" and "OUT 1" are in a group.

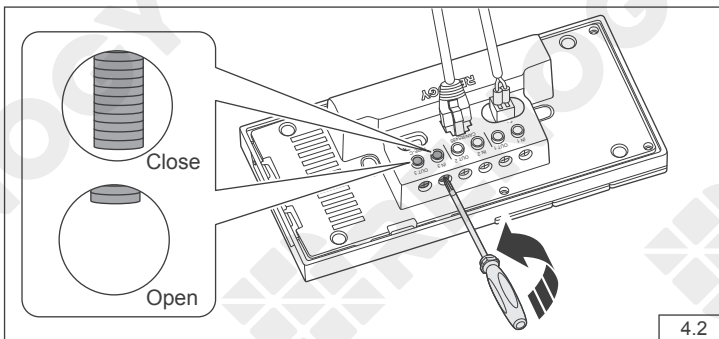

4.2

Use a Phillips screwdriver to turn the wire hatch screw counterclockwise. Make sure that the terminal hatch is completely open.

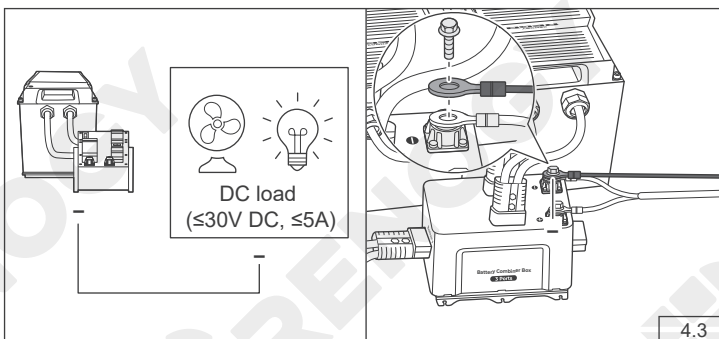

4.3

Connect one of the ring terminals of the tray cable to the negative terminal of the DC power supply, and connect the other end to the negative pole of the load.

Load Wiring (Optional)

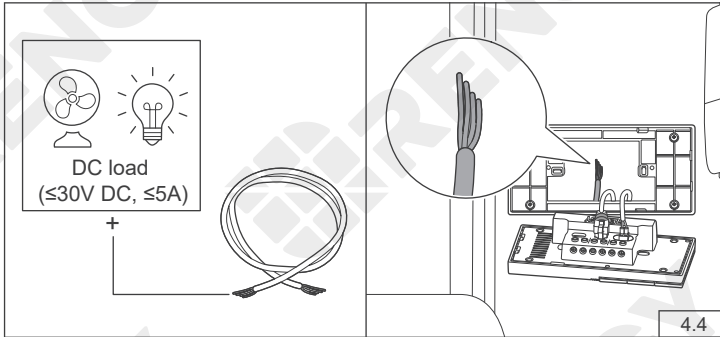

Connect the bare wire to the positive pole of the load, and reserve the other end in the installation hole.

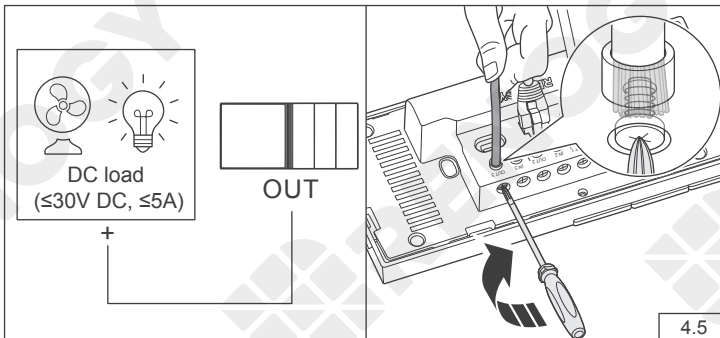

Insert the reserved tray cable connecting to the positive terminal of the load (appliance) into the Renogy ONE output terminal (OUT), and use a Phillips screwdriver to turn the wire hatch screw clockwise.

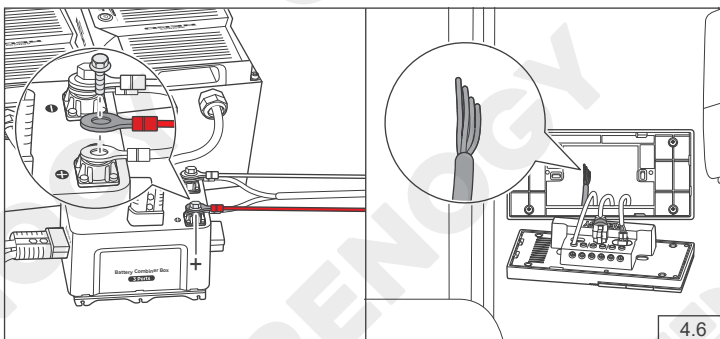

Connect the other ring terminal of the adapter cable to the positive terminal of the DC power supply, and reserve the other end in the installation hole.



Load Wiring (Optional)

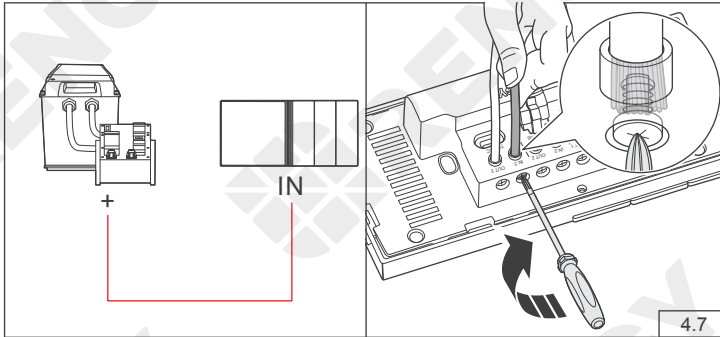

Insert the tray cable connecting to the positive end of the DC power supply into the Renogy ONE input terminal (IN), and use a screwdriver to turn the wire hatch screw clockwise.

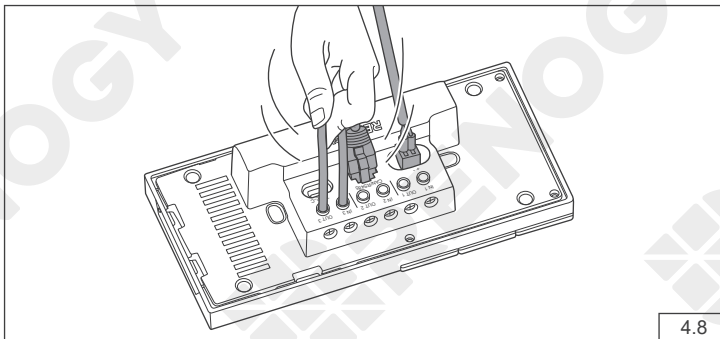

Make sure all connections are tight and secure.



Mounting



- Make sure that Renogy ONE is installed securely to prevent it from falling off.

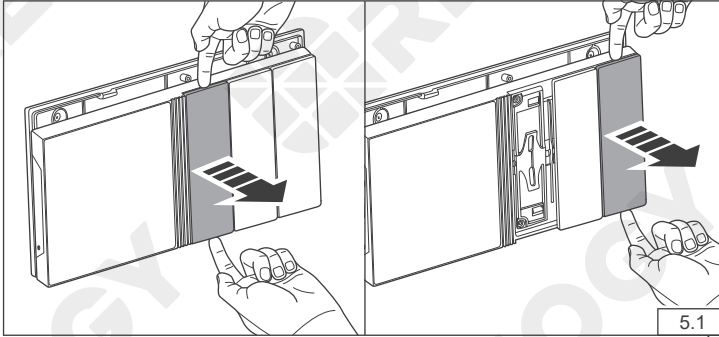

5.1

Disassemble Panel Switch 1 and Panel Switch 3 from Renogy ONE.

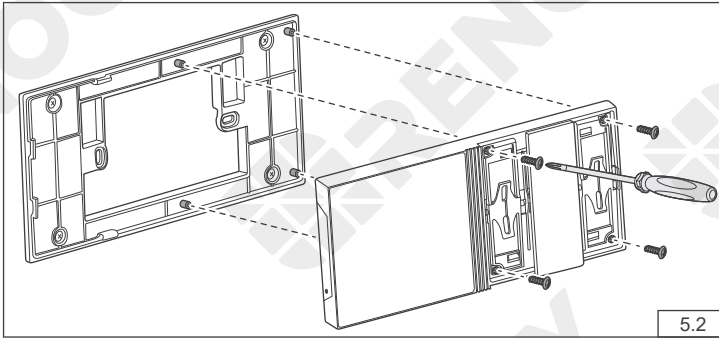

5.2

Put the Renogy ONE on the base, and use the Phillips screwdriver to tighten the four M2 screws through the mounting holes, so that the Renogy ONE is fixed on the base.

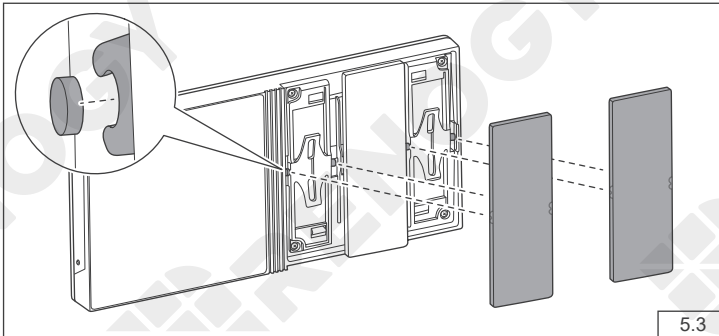

5.3

Align the snap on the back of the panel switch with the snap on the installation position and press firmly to complete the assembly of Panel Switch 1 and Panel Switch 3 on Renogy ONE.



Activation

For initial use, Renogy ONE guides you through WLAN connection, pairing, and device adding via the activation wizard.



- You can tap **Skip** in the upper-right corner of the main interface on Renogy ONE to skip some of the wizard steps. You can re-complete the activation operations through **Settings**.
- To monitor and operate connected devices remotely, you need to pair Renogy ONE with your DC Home app under stable Internet access.

WLAN

On the home page of Renogy ONE, go to **Settings > System > Network > WLAN**.



- Renogy ONE supports 2.4 GHz Wi-Fi only. You can also connect Renogy ONE to the Internet through a mobile hotspot.
- The steps listed in this chapter are based on Renogy ONE V1.1.15.0_V7_13 and DC Home V1.8.8 for iOS. The actual steps of the Renogy ONE and DC Home in use prevail.

Pairing with App

If you did not follow the system wizard to pair Renogy ONE with your DC Home app, follow the steps below.

Method 1: Go to **Settings > System > Pairing with App**. Open the DC Home app, tap **+ > Add Renogy ONE**. Scan the QR code to complete pairing.

Method 2: Tap  on the main interface. Open the DC Home app, tap **+ > Add Renogy ONE**. Enter the SN of Renogy ONE to complete pairing.

After successful pairing, you can control smart accessories and create smart scenes through the DC Home app.



- Ensure both Renogy ONE and your phone where the DC Home app runs are connected to the Internet during pairing.
- The DC Home app should be in the up-to-date version.



Operation

Activation

WLAN

Pairing with App

Add Devices

Power On/Off

Control
External Loads

Add Devices

How to add devices to Renogy ONE varies depending on the communication connection type.

- For wired communication (RV-C/RS485), the device is automatically recognized by and added to Renogy ONE.
- For wireless communication (Bluetooth/Zigbee), tap **Settings** and choose **Add Devices** on Renogy ONE.



- For adding Renogy energy devices via Bluetooth to Renogy ONE, make sure the device Bluetooth is turned on.
- For adding smart accessories to Renogy ONE via Zigbee, resetting accessories is required. For details, refer to the instructions in the user manuals of specific smart accessories.
- To ensure good compatibility, it is recommended to use Renogy energy devices and smart accessories.
- For adding Bluetooth devices to Renogy ONE through the DC Home app, refer to the user manual of Renogy ONE at renogy.com.

Power On/Off

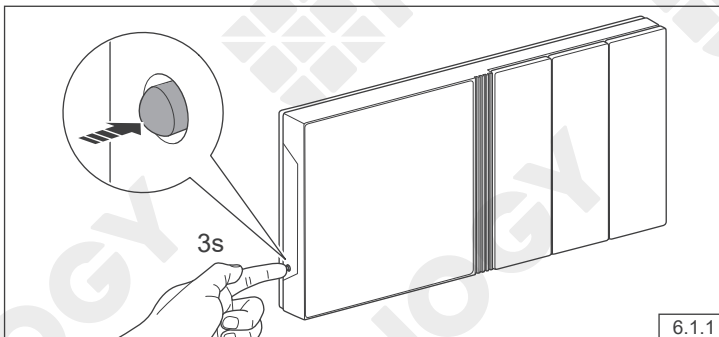

Press and hold the Power Button on Renogy ONE for 3 seconds to power it on or off.



Operation

Activation

WLAN

Pairing with App

Add Devices

Power On/Off

Control
External Loads

Control External Loads

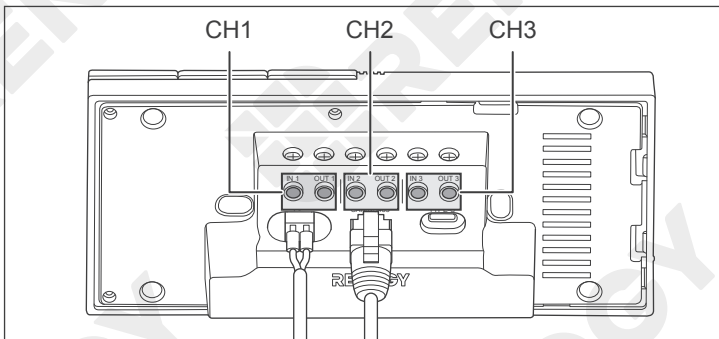

The 3 panel switches of Renogy ONE correspond to 3 panel relays respectively.

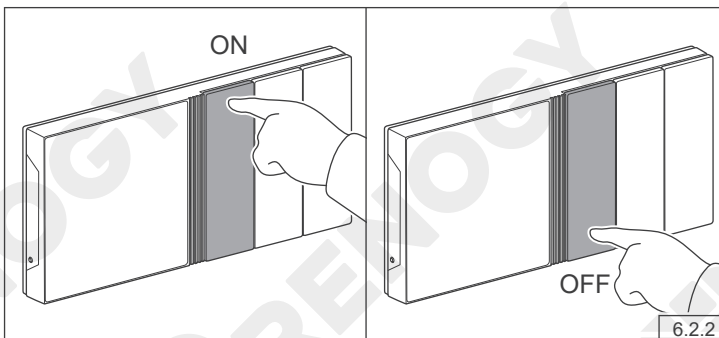
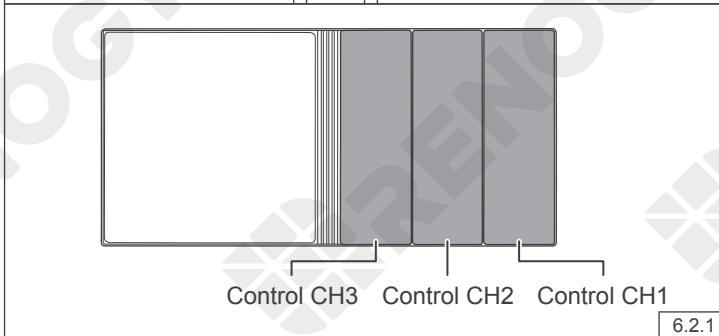

Press the panel switches to power on/off external loads.

You can modify the above default settings or set more functions for the panel switch through the DC Home app.

On the main interface of the DC home app, go to **Scenes** and tap **+**. Set the conditions and actions in **When** and **Do** respectively, and then tap **Save**.



Maintenance

For optimum performance, it is recommended to perform these tasks regularly.

- Ensure the Renogy ONE is installed in a clean, dry and ventilated area.
- Ensure there is no damage or wear on the cables.
- Make sure the communication cable connectors and power connectors are secure.
- Ensure the firmness of the connectors and check if there are any loose, damaged or burnt connections.
- Ensure that the Battery indicator and Fault indicator are in normal state.
- Ensure there is no corrosion, insulation damage, or discoloration marks of overheating or burning.

FCC Statement

This device complies with Part 15 of the FCC Rules. Operation is subject to the following two conditions:

- (1) This device may not cause harmful interference.
- (2) This device must accept any interference received, including interference that may cause undesired operation.

This equipment has been tested and found to comply with the limits for a Class B digital device, pursuant to Part 15 of the FCC Rules. These limits are designed to provide reasonable protection against harmful interference in a residential installation. This equipment generates uses and can radiate radio frequency energy and, if not installed and used in accordance with the instructions, may cause harmful interference to radio communications. However, there is no guarantee that interference will not occur in a particular installation. If this equipment does cause harmful interference to radio or television reception, which can be determined by turning the equipment off and on, the user is encouraged to try to correct the interference by one or more of the following measures:

- (1) Orient or relocate the receiving antenna.
- (2) Increase the separation between the equipment and receiver.
- (3) Connect the equipment into an outlet on a circuit different from that to which the receiver is connected.
- (4) Consult the dealer or an experienced radio/TV technician for help.

FCC Radiation Exposure Statement

This equipment complies with FCC radiation exposure limits set forth for an uncontrolled environment. This equipment should be installed and operated with minimum distance 20cm between the radiator & your body.



Renogy Empowered

Renogy aims to empower people around the world through education and distribution of DIY-friendly renewable energy solutions.

We intend to be a driving force for sustainable living and energy independence.

In support of this effort, our range of solar products makes it possible for you to minimize your carbon footprint by reducing the need for grid power.



Live Sustainably with Renogy

Did you know? In a given month, a 1KW solar energy system will...



Save 170 pounds of coal from being burned



Save 300 pounds of CO₂ from being released into the atmosphere



Save 105 gallons of water from being consumed



Renogy Power **PLUS**

Renogy Power Plus allows you to stay in the loop with upcoming solar energy innovations, share your experiences with your solar energy journey, and connect with like-minded people who are changing the world in the Renogy Power Plus community.

Also, follow us on Youtube @Renogy Solar, Facebook @Renogy, and Instagram @renogyofficial.

Visit [renogy.com](https://www.renogy.com) to find relevant documentation or get more support via "[Contact Us](#)".
Renogy reserves the right to change the contents of this manual without notice.

Join the Renogy Power Plus Community
by downloading the DC Home App.
Find your e-warranty here, and more.

